

**ICOP latest versions: Part titles and publication dates (English)**

<b>Part</b>	<b>Title</b>	<b>Latest version date</b>
Part 1	Foreword, Introduction, Scope, Structure, Terms and definitions, Principles and controls	2014-Jul-01
Part 2	Detailed guidance	2014-Jul-01
Part 3, Annex A	Risk assessment	2013-Sep-01
Part 3, Annex B	Safety method statements	2013-Sep-01
Part 3, Annex C	List of standards referred to within the code of practice	2013-Sep-01
Part 3, Annex D	Harness comfort and adjustability test	2013-Sep-01
Part 3, Annex E	Other types of lanyard	2013-Dec-01
Part 3, Annex F	Safety considerations when installing or placing anchor devices for use in rope access	2013-Sep-01
Part 3, Annex G	Suspension intolerance	2014-Jul-10
Part 3, Annex H	Equipment inspection checklist	2013-Sep-01
Part 3, Annex I	List of information to be recorded following a detailed inspection of rope access equipment	2013-Sep-01
Part 3, Annex J	Resistance to chemicals and other properties of some of the man-made fibres used in the manufacture of rope access equipment	2013-Sep-01
Part 3, Annex K	Typical method of descending and ascending using IRATA International rope access	2013-Sep-01
Part 3, Annex L	Other harness-based work at height access methods	2014-Aug-01
Part 3, Annex M	Use of tools and other work equipment	2013-Sep-01
Part 3, Annex N	Recommended list of information to be kept on site	2013-Sep-01
Part 3, Annex O	The effect of wind and height on working times	2013-Sep-01
Part 3, Annex P	Recommended actions for the protection of anchor lines	2013-Sep-01
Part 3, Annex Q	Fall factors, fall distances and associated risks	2013-Sep-01
Part 4	Local legislation: UK	2013-Dec-01



# **IRATA International code of practice for industrial rope access**

## **Part 1: Foreword, Introduction, Scope, Structure, Terms and definitions, Principles and controls**

**July 2014**

The first edition of Part 1 was published in January 2010.  
The second edition was published in March 2013 plus amendments in September 2013.  
This third edition was published in July 2014.

Amendments issued since publication in July 2014

Amd. No	Date	Text affected

Published by:

IRATA International  
First Floor, Unit 3  
Eurogate Business Park  
Ashford  
Kent  
TN24 8XW  
England

Tel: +44 (0)1233 754600

Email: [info@irata.org](mailto:info@irata.org)

Website: [www.irata.org](http://www.irata.org)

Copyright © IRATA International 2014

ISBN: 978-0-9544993-3-4

## Commendations

### IRATA International code of practice for industrial rope access

*Although there is a steady decline in the number of injuries caused by falls; falls from height remain the most common kind of workplace fatality. They are the biggest single cause of serious and fatal injuries arising from construction and maintenance activities. Safety when working at height is essential, and making sure that people use access equipment properly is a key part of this.*

*HSE recognises that, within the variety of work at height methods available, rope access is an accepted technique to use in appropriate circumstances.*

*I am pleased to continue HSE's support of IRATA's guidance in this area. This voluntary code of practice sets out good practice for individuals and organisations using rope access equipment and will help to ensure that health and safety risks in this area are minimised or avoided.*



**Philip White**

**Chief Inspector of Construction, HSE**

01 January 2010

*The Offshore Safety Division of HSE concurs with the continued general support by HSE of IRATA's voluntary code of practice. Use of this code of practice is also commended for offshore working when rope access methods are required.*

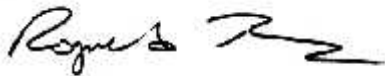

**Rog Thomson**

**HM Principal Inspector of Health and Safety,**

**Offshore Safety Division**

01 January 2010

**NOTE** The word 'voluntary' used in the commendations is intended to signify that compliance with the IRATA International code of practice is not a legal requirement under UK law. However, it is mandatory for members of IRATA International to comply with the principles of the code of practice and this is a condition of their membership.

## Part 1: Foreword, Introduction, Scope, Structure, Terms and definitions, Principles and controls

### Foreword

IRATA International is recognized as the world's leading authority on industrial rope access. Established in the UK in 1988 as the Industrial Rope Access Trade Association, an increase in membership worldwide led to the name IRATA International to reflect this. The association's aim is the promotion and development of the safe system that it has pioneered since its inception and to support its member companies and trained technicians to enable them to work in a safe and effective manner.

There are several types of IRATA International membership. *Full member* companies are either *trainer members* or *operator members* (or both). These types of members have full voting rights. There are probationary levels of these memberships, which also have full voting rights. There are two more types of membership, neither with voting rights: *associate*, open to organizations such as manufacturers, architects and authoritative bodies, and *individual*, open, for example, to consultants and rope access technicians.

Trainer and operator members of the association have to meet specific entrance qualifications and are subject to regular audits to ensure they meet IRATA International's requirements for quality assurance, safety, training and work practices.

The benefits of the IRATA International system are demonstrated by the low level of accidents and incidents reported by members, which after independent collation and study are published annually as the *IRATA International Work and Safety Analysis*. The latest version of the work and safety analysis can be viewed by visiting [www.irata.org](http://www.irata.org).

Monitoring shows that the IRATA International system of effective training, diligent supervision and a proven method protects lives and guards against injury. It also demonstrates that IRATA International operates more safely than the work-at-height industry as a whole. In addition, the several references in this code of practice to the *unlikely* event of failure and the steps then taken to minimize the risk, even though statistically unlikely, highlights the cautious, preventative approach taken by IRATA International to safety.

The code of practice has been compiled using the experience of established rope access companies and is the result of many years of experience working with various national, international, regional and trade-based health and safety organizations, to which IRATA International is indebted for their advice and assistance.

Members of IRATA International are required, as a condition of membership, to comply with the principles of the code of practice.

A free download of the latest version of this code of practice, including the informative annexes in Part 3, is available from [www.irata.org](http://www.irata.org).

It should be noted that the code of practice is not intended as a full interpretation of the law and does not relieve employers of their duties under the various legal requirements that may relate to their specific location, situation and applications. It should also be noted that the code of practice applies to industrial rope access work only, where the prime activity is the work itself. It is not intended to cover, for example, leisure activities or emergency evacuation systems and their procedures, although trainees in such other activities would probably benefit from a level of protection similar to that advised within these pages.

Although care has been taken to ensure, to the best of IRATA International's knowledge, that the content of this code of practice is accurate to the extent that it relates to either matters of fact or accepted practice or matters of opinion at the time of publication, IRATA International assumes no

responsibility for any errors or misinterpretations of such content or any loss or damage arising from or related to its use.

## **Acknowledgements**

IRATA International wishes to express its gratitude to the following in respect of the preparation of this revision of the code of practice:

*Writer/compiler:* Paul Seddon OBE

*Review panel members:* Justin Atkinson, Graham Burnett, Jonathan Capper, Russ Manton, Steve Murphy, Paul Ramsden, David Thomas, Mark Wright

*Drawings:* Angela Wright

Comments received by other members of the association were also much appreciated.

## Introduction

IRATA International's rope access system is a safe method of working at height, where ropes and associated equipment are used to gain access to and egress from the workplace, and to be supported at it.

The advantage of using rope access methods lies mainly in the safety and speed with which workers can get to or from difficult locations and then carry out their work, often with minimal impact on other operations. Another major benefit is that the combination of the total man-hours and the level of risk for a particular task (man-at-risk hours) is often reduced when compared with other means of access and their associated risks and cost.

The primary objective when using rope access methods is to plan, manage and carry out the work with a goal of no accidents, incidents or dangerous occurrences, i.e. to ensure a safe system of work is maintained at all times, and with no damage to property or harm to the environment. IRATA International has in place a continuously evolving regime with procedures that members are required to follow, which are monitored for compliance to ensure that a safe system of work is established and maintained. This sets IRATA International member companies apart from rope access companies that are not subject to such a rigorous scheme.

Like any other method of working at height, the application of rope access should be regarded as a complete system, in which planning, management, competence and suitable equipment should be treated with equal importance, as each is dependent on the others to ensure a safe system of work. This code of practice gives recommendations and guidance on the use of rope access methods to provide such a safe system of work. Part 1 sets out fundamental principles and controls. Part 2 expands on Part 1, providing more detailed guidance. Part 3 consists of informative annexes, which give advice on the rope access aspect of associated work practices and information on other relevant topics. Several of these annexes are still under development. Part 4 gives links to relevant national legislation and Part 5 provides a bibliography. The parts should be read in conjunction with each other, particularly Part 1 with Part 2 and Part 2 with relevant informative annexes in Part 3.

## 1.1 Scope

This code of practice gives recommendations and guidance on the use of IRATA International rope access methods, including training, to provide a safe system of work. It is intended for use by IRATA International members, IRATA International rope access technicians, national or regional enforcement agencies, safety officers and those who commission rope access work, e.g. building contractors; multi-national oil and gas companies; the renewable energy sector. This code of practice is applicable to the use of IRATA International rope access methods for industrial purposes, i.e. for access to buildings, other structures (on or offshore) or natural features, such as cliff faces, where ropes are used as the primary means of access, egress or support and as the primary means of protection against a fall.

This code of practice is not intended to apply to the use of rope-based access methods for leisure activities, arboriculture, general steeplejack methods or emergency personal evacuation systems, or to the use of rope-based access (line rescue) techniques by fire brigades and other emergency services for rescue work or for rescue training.

*NOTE* Throughout this code of practice, the term rope access is intended to mean rope access for industrial purposes, unless otherwise stated.



## 1.2 Structure

**1.2.1** This code of practice consists of several parts. Generally, clauses and figures in each part are numbered to match the number of the part, e.g. in Part 2: 2.2, *Planning and management*, Figure 2.3 — *Example of a scaffold knot*. The exception is Part 3, which is a series of informative annexes. Here, the clauses and figures are given a letter to match the title of the particular annex, e.g. in Annex A: A.1, A.2.

**1.2.2** The following list details the part titles and clause titles in each part up to the fourth level of numbering, e.g. 2.5.3.2. Clause titles at lower levels of numbering, e.g. 2.7.1.5.1 *Work restraint (travel restriction) equipment*, are omitted. Under Part 3, only the main title of each informative annex is listed. This is to allow flexibility in the development of each topic to be covered.

*NOTE* This code of practice is intended to be a live, website-based document and is, therefore, subject to change, so clause numbers and possibly part numbers could change over time.

### **Part 1: Foreword, Introduction, Scope, Structure, Terms and definitions, Principles and controls**

Foreword

Introduction

- 1.1 Scope
- 1.2 Structure
- 1.3 Terms and definitions
- 1.4 Principles and controls
  - 1.4.1 General
  - 1.4.2 Principles
    - 1.4.2.1 Planning
    - 1.4.2.2 Training and competence
    - 1.4.2.3 Management and supervision
    - 1.4.2.4 Selection, care, maintenance and inspection of equipment
    - 1.4.2.5 Work methods
    - 1.4.2.6 Exclusion zones
    - 1.4.2.7 Emergency procedures
    - 1.4.2.8 Expanded techniques
  - 1.4.3 Quality and safety controls

### **Part 2: Detailed guidance**

Introduction

- 2.1 General
  - 2.2 Planning and management
    - 2.2.1 Objective
    - 2.2.2 Planning
    - 2.2.3 Pre-work analysis
    - 2.2.4 Risk assessment

- 2.2.5 Safety method statements
- 2.2.6 Procedures and personnel to be in place before work begins
  - 2.2.6.1 Procedures
  - 2.2.6.2 Personnel
- 2.3 Selection of rope access technicians
  - 2.3.1 General
  - 2.3.2 Experience, attitude and aptitude
- 2.4 Competence
- 2.5 Training
  - 2.5.1 General
  - 2.5.2 IRATA International training, assessment and certification
  - 2.5.3 Additional skill levels
    - 2.5.3.1 General
    - 2.5.3.2 Trainers and instructors
    - 2.5.3.3 Assessors (Level A/3)
    - 2.5.3.4 Auditors
- 2.6 Rope access managers, rope access safety supervisors and other supervisory/management items
  - 2.6.1 Rope access managers
  - 2.6.2 Rope access safety supervisors
  - 2.6.3 Other supervisory/management items
    - 2.6.3.1 Disciplined working
    - 2.6.3.2 Access by non-IRATA International qualified personnel
    - 2.6.3.3 Company nominated person (the technical contact)
- 2.7 Selection of equipment
  - 2.7.1 General
    - 2.7.1.1 Application-specific assessment
    - 2.7.1.2 Legal requirements
    - 2.7.1.3 Standards
    - 2.7.1.4 Load ratings/minimum static strength
    - 2.7.1.5 Equipment for work restraint, work positioning and fall arrest
    - 2.7.1.6 Limits of equipment use and compatibility
    - 2.7.1.7 Knowledge of equipment
  - 2.7.2 Ropes (anchor lines)
  - 2.7.3 Harnesses
  - 2.7.4 Connectors
  - 2.7.5 Descending devices
  - 2.7.6 Ascending devices
  - 2.7.7 Back-up devices

- 2.7.8 Lanyards and slings
  - 2.7.8.1 General
  - 2.7.8.2 Device lanyards and anchor lanyards
  - 2.7.8.3 Anchor slings
  - 2.7.8.4 Selection criteria for device lanyards, anchor lanyards and anchor slings
  - 2.7.8.5 Other information on lanyards
- 2.7.9 Anchors
- 2.7.10 Protectors for anchor lines
- 2.7.11 Work seats
- 2.7.12 Helmets
- 2.7.13 Clothing and protective equipment
- 2.8 Marking and traceability
- 2.9 Records
- 2.10 Inspection, care and maintenance of equipment
  - 2.10.1 General procedures
  - 2.10.2 Equipment manufactured from man-made fibres
  - 2.10.3 Metal equipment
  - 2.10.4 Protective helmets
  - 2.10.5 Disinfection of equipment
  - 2.10.6 Equipment exposed to a marine environment
  - 2.10.7 Storage
  - 2.10.8 Equipment withdrawn from service
  - 2.10.9 Lifespan
  - 2.10.10 Alterations to equipment
- 2.11 Primary rope access work methods
  - 2.11.1 Double protection
  - 2.11.2 The anchor system (anchors and anchor lines)
    - 2.11.3 Use of anchor lines
      - 2.11.3.1 Rigging and de-rigging
      - 2.11.3.2 Protection methods for anchor lines
    - 2.11.4 Additional safety measures
  - 2.11.5 The use of knots
  - 2.11.6 Work teams
  - 2.11.7 Pre-work checking
  - 2.11.8 Exclusion zones
    - 2.11.8.1 General
    - 2.11.8.2 Protection of third parties
    - 2.11.8.3 Anchor area exclusion zone
    - 2.11.8.4 Working edge hazard zone

- 2.11.9 Communication
- 2.11.10 Welfare
- 2.11.11 Emergency procedures
- 2.11.12 Reporting of incidents and accidents
- 2.11.13 End of shifts
- 2.11.14 Termination of a job
- 2.11.15 Expanded techniques

### **Part 3: Informative annexes**

Annex A: Risk assessment

Annex B: Safety method statements

Annex C: List of standards referred to within the code of practice

Annex D: Harness comfort and adjustability test

Annex E: Other types of lanyard

Annex F: Safety considerations when installing or placing anchor devices for use in rope access

Annex G: Suspension intolerance (formerly known as suspension trauma)

Annex H: Equipment inspection checklist

Annex I: List of information to be recorded following a detailed inspection of rope access equipment

Annex J: Resistance to chemicals and other properties of some of the man-made fibres used in the manufacture of rope access equipment

Annex K: Typical method of descending and ascending using IRATA International rope access techniques

Annex L: Other harness-based work at height access methods

Annex M: Use of tools and other work equipment

Annex N: Recommended list of information to be kept on site

Annex O: The effect of wind and height on working times

Annex P: Recommended actions for the protection of anchor lines

Annex Q: Fall factors, fall distances and associated risks

### **Part 4: Legislation**

Local legislation

### **Part 5: Bibliography, further reading and useful addresses**

### 1.3 Terms and definitions

For the purposes of all parts of this code of practice, including the informative annexes, the following terms and definitions apply:

#### **anchor**

general term used as a noun to describe a fitted or unfitted anchor device, or a structural anchor containing an anchor point, or as a verb to describe the act of connecting to a fitted anchor device or a structural anchor

#### **anchorage**

structure or natural feature that provides an anchorage point (see **Figure 1.1**)

*NOTE Two examples of a natural feature are a rock face and a tree.*

#### **anchorage point**

particular place on an anchorage used for the attachment of an anchor device (see **Figure 1.1**)

#### **anchor device**

personal fall protection equipment comprising an assembly of elements with one or more anchor points or mobile anchor points and which is removable from the structure or natural feature (see **Figure 1.1**)

#### **anchor lanyard**

lanyard connected to the main attachment point of the harness, which normally incorporates a connector and which is used for connection to an anchor point

*NOTE Some anchor lanyards are also known as cow's tails.*

#### **anchor line**

flexible line connected to a reliable anchor to provide a means of support, restraint or other safeguard for a person wearing an appropriate harness in combination with other devices

*NOTE An anchor line may be a working line or a safety line.*

#### **anchor line device**

collective term for ascending device, descending device and back-up device

*NOTE Anchor line devices are also known as rope adjustment devices.*

#### **anchor point**

point on an anchor device or structural anchor used for the connection of personal fall protection equipment (see **Figure 1.1**)

#### **anchor sling**

sling or strop made from textiles, wire rope or chain, which is used to attach to a structure or natural feature to provide an anchor point for an anchor line or for the direct connection of the rope access technician

#### **ascending device**

anchor line device used primarily to assist progression along an anchor line and for positioning the rope access technician on it, which, when attached to an anchor line of appropriate diameter, locks under load in one direction and slips freely in the opposite direction

#### **back-up device**

anchor line device for a safety line, which accompanies the user during changes of position or allows adjustment of the length of the safety line and which locks automatically to the safety line, or only allows gradual movement along it, when a sudden load occurs

**certificate of conformity**

document certifying that the supplied goods meet the claimed compliance and/or specifications

**competent person**

designated person suitably trained or qualified by knowledge and practical experience to enable the required task or tasks to be carried out properly

**connector**

openable device used to connect components, which enables the user to link himself or herself directly or indirectly to an anchor point

**descending device**

manually-operated, friction-inducing anchor line device which, when attached to an anchor line of appropriate type and diameter, allows the user to achieve a controlled descent and a stop with hands off anywhere on the anchor line

**deviation**

redirection of the path of the anchor lines from the anchor points to avoid abrasion and other potential causes of damage to the anchor lines or to provide more accurate access for the rope access technician

**deviation anchor**

anchor placed primarily to alter the direction of an anchor line and installed at a distance (unspecified) from the anchor point(s) used for the first attachment of an anchor line

**device lanyard**

lanyard used to provide a link between the user's harness and the anchor line device

*NOTE Some device lanyards are also known as cow's tails.*

**dynamic rope**

rope specifically designed to absorb energy in a fall by extending in length, thereby minimising the impact load

**energy absorber**

component or components in a fall arrest system designed to minimize the impact load generated in a fall

**fail to safe**

revert to a safe condition in the event of a breakdown, failure, or mismanagement of a critical nature

**failure load**

minimum breaking load of an item of equipment when it is new

**fall factor**

length of a potential fall divided by the length of rope or lanyard available to arrest it

**kernmantel rope**

textile rope consisting of a core enclosed by a sheath

*NOTE The core is usually the main load bearing element and typically consists of parallel elements which have been drawn and turned together in single or several layers, or of braided elements. The sheath is generally braided and protects the core, for example from external abrasion and ultra-violet degradation.*

### **lifting equipment**

work equipment for lifting or lowering loads, including its attachments used for anchoring, fixing or supporting it, e.g. chain or rope sling or similar; ring; link; hook; plate-clamp; shackle; swivel; eyebolt; webbing

### **low-stretch rope**

textile rope with lower elongation and, therefore, less energy absorbing characteristics than dynamic rope

*NOTE* Low stretch rope is sometimes known as semi-static rope.

### **maximum rated load (RL<sub>MAX</sub>)**

maximum mass of one or more persons, including tools and equipment carried, with which a component of a rope access system can be used, as specified by the manufacturer

*NOTE 1* Maximum rated load is expressed in kilograms.

*NOTE 2* See also safe working load (SWL) and working load limit (WLL).

### **minimum rated load (RL<sub>MIN</sub>)**

minimum mass of one or more persons, including tools and equipment carried, with which a component of a rope access system can be used, as specified by the manufacturer

*NOTE* Minimum rated load is expressed in kilograms.

### **proof load**

test load applied to verify that an item of equipment does not exhibit permanent deformation under that load, at that particular time

*NOTE* The result can then be theoretically related to the performance of the test piece under its expected conditions in service.

### **re-anchor**

anchor installed at a distance (unspecified) from the anchor point(s) used for the first attachment of an anchor line, to which the anchor line is additionally attached, and which is not a deviation anchor or an anchor placed simply to maintain the position of an anchor line

*NOTE* Re-anchors are also known as re-belays and intermediate anchors.

### **rigging for rescue**

establishing a rescue system which enables workmate retrieval to take place without the need for a rescuer to descend or ascend to the position of the injured person

### **rope access**

method of using ropes, in combination with other devices, by which a user descends or ascends a working line to get to or from the workplace, and for work positioning, while further protected by a safety line, such that both lines are connected to the user's harness and separately secured to a reliable anchorage in such a way that a fall is prevented or arrested

*NOTE 1* Ropes used for descending, ascending, work positioning or as a safety line are known as anchor lines.

*NOTE 2* In this context, the term 'ropes' includes appropriate textile ropes, wire ropes and webbing.

### **safety line controller (in Annex L)**

person paying out or taking in safety lines while protecting another person against a fall from a height

**safe working load (SWL)**

designated maximum working load of an item of equipment under particular, specified conditions

*NOTE See also working load limit (WLL) and maximum rated load (RL<sub>MAX</sub>).*

**safety line**

anchor line provided as a safeguard to protect against falls if the rope access technician slips or if the primary support (e.g. the working line), anchor or positioning mechanism fails

**safety method statement**

document prepared by the employer describing how a particular job (or types of job where these will be essentially identical) should be undertaken to ensure that any risks to the health and safety of the workers, or others who may be affected, are minimised

**screwlink**

type of connector formed as an open loop, which is closed by a threaded sleeve

*NOTE Screwlinks are also known as maillon rapides and quicklinks.*

**structural anchor**

element or elements of an anchor incorporated into a structure or natural feature and not intended to be removed (see **Figure 1.1**)

*NOTE 1 A structural anchor may contain an anchor point.*

*NOTE 2 A structural anchor is not an anchor device.*

*NOTE 3 An example of a structural anchor is where an element such as an eyebolt is welded or resin bonded to the structure.*

**suspended scaffold**

scaffold suspended by means of ropes or chains and capable of being raised or lowered by such means but does not include a boatswain's chair or similar apparatus

**working line**

anchor line used primarily for access, egress, work positioning and work restraint

**working load limit (WLL)**

maximum load that can be lifted by an item under conditions specified by the manufacturer

*NOTE See also safe working load (SWL) and maximum rated load (RL<sub>MAX</sub>).*

**workmate retrieval**

removal by one or more operatives of an incapacitated member of their rope access work team from a place of danger to a place of safety

*NOTE Workmate retrieval is also known as workmate rescue.*

**work positioning**

technique that enables a person to work supported in tension or suspension by personal fall protection equipment in such a way that a fall from a height is prevented or restricted

**work restraint**

technique whereby a person is prevented, by means of personal fall protection equipment, including an appropriate belt or harness, from reaching zones where the risk of a fall from a height exists



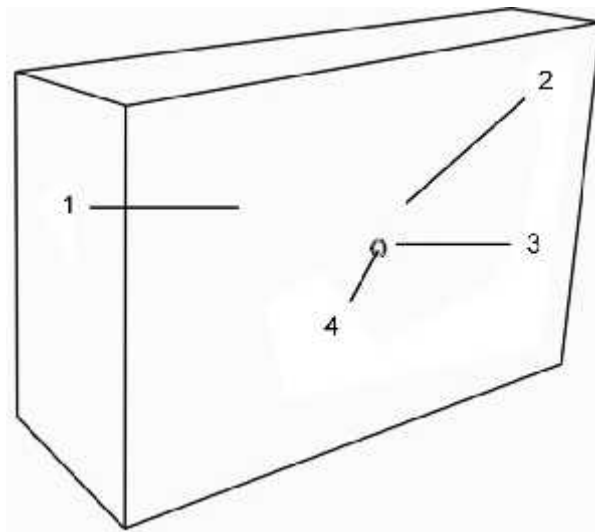

a) Concrete wall

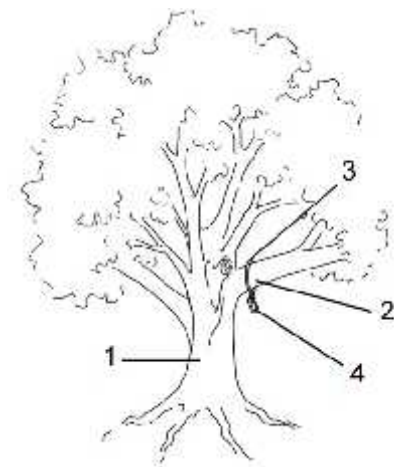

b) Natural feature

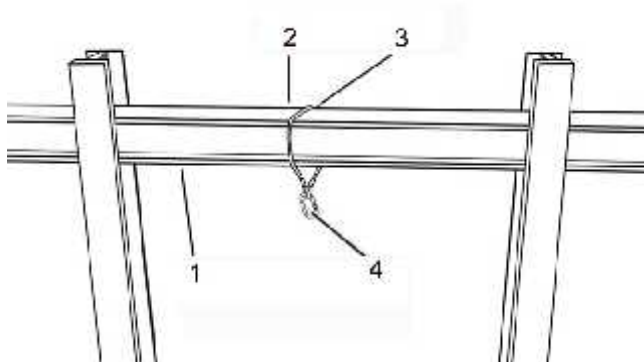

c) Steel structure

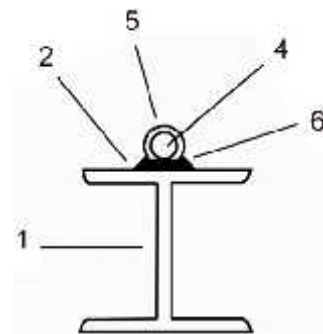

d) Structural anchor with an anchor point

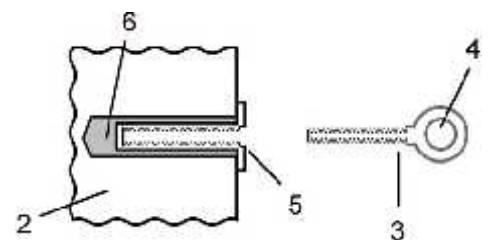

e) Structural anchor without an anchor point (anchor device unfitted)

**Key**

- 1 Anchorage
- 2 Anchorage point
- 3 Anchor device
- 4 Anchor point
- 5 Structural anchor
- 6 Permanent fixing element (e.g. welding; riveting; resin bonding)

**Figure 1.1 — Examples of anchorages, anchorage points, anchor devices, anchor points and structural anchors**

## **1.4 Principles and controls**

### **1.4.1 General**

**1.4.1.1** The essential elements of a safe system of work include:

- a) proper planning and management;
- b) the use of trained, competent persons;
- c) good supervision;
- d) the careful selection of appropriate equipment;
- e) proper care, maintenance and inspection of equipment;
- f) proper control of working methods, including:
  - (i) provision for emergencies;
  - (ii) the protection of third parties;
  - (iii) the use of work equipment;
  - (iv) exclusion zones.

**1.4.1.2** The principles and controls of the IRATA International rope access system are given in **1.4.2** and **1.4.3**. These should not be taken to be exhaustive, as other elements may need to be taken into account, depending on the specific work task and work situation.

### **1.4.2 Principles**

#### **1.4.2.1 Planning**

**1.4.2.1.1** Rope access work should be planned (and managed) by a person who is designated as being responsible for maintaining a safe system of work.

**1.4.2.1.2** Before rope access work commences there should be a documented:

- a) pre-work analysis, to establish whether rope access methods are appropriate;
- b) risk assessment, to identify any hazards, to assess the likelihood of an incident occurring and to establish control measures to minimize the risk;
- c) safety method statement, which clearly defines work procedures.

#### **1.4.2.2 Training and competence**

Rope access technicians should be:

- a) trained and competent to carry out any access tasks that they are to undertake, including workmate rescue/retrieval and should only be allocated tasks appropriate to their level of training;
- b) sufficiently physically fit and free from any disability that might prevent them from working safely at height;

- c) competent in the pre-use inspection of their equipment, including an understanding of when equipment should be withdrawn from service.

#### **1.4.2.3 Management and supervision**

**1.4.2.3.1** There should be proper management and supervision of the rope access worksite.

**1.4.2.3.2** Managers responsible for the rope access site should be:

- a) competent in management skills;
- b) have adequate knowledge of rope access technical procedures to enable them to manage the rope access work site competently.

**1.4.2.3.3** Worksites using rope access require the supervision of rope access safety and of the work project itself. These two types of supervision may be the responsibility of different people or the same person. This code of practice covers only the supervision of rope access safety.

**1.4.2.3.4** Under the IRATA International training, assessment and certification scheme, only Level 3 rope access technicians are permitted to be rope access safety supervisors. Rope access safety supervisors should be:

- a) competent in supervisory skills;
- b) competent in rope access techniques appropriate to the particular worksite and should understand the limitation of those techniques;
- c) responsible for hazard identification and risk assessment for rope access related tasks;
- d) competent in workmate rescue/retrieval techniques appropriate to each worksite and be able to organize and put into effect a workmate rescue/retrieval appropriate to that worksite.

#### **1.4.2.4 Selection, care, maintenance and inspection of equipment**

**1.4.2.4.1** The selection and purchase of equipment should be approved by a person with knowledge of the technical specification required.

**1.4.2.4.2** Equipment used in any rope access system should be compatible and should be appropriate to its application.

**1.4.2.4.3** Equipment should be capable of withstanding any foreseeable loads without catastrophic damage to any component of the system.

**1.4.2.4.4** Equipment should be selected which, wherever possible, fails to safe.

**1.4.2.4.5** Equipment should be inspected before each use (pre-use check) and more thoroughly at regular intervals (detailed inspection). Results of all detailed inspections should be recorded and records should also be kept of use and maintenance.

**1.4.2.4.6** Equipment should be correctly stored and maintained, and should be traceable back to the manufacturer or his authorized representative.

**1.4.2.4.7** Rope access technicians should have clothing and similar equipment appropriate to the work situation and conditions.

#### **1.4.2.5 Work methods**

**1.4.2.5.1** Of primary importance in the IRATA International rope access system is the principle of double protection. It is essential to include the provision of at least one additional means of protection to prevent a rope access technician falling, for example, a safety line in conjunction with the working line. This means that, should any one item fail within the suspension system, there is an adequate safety back-up to protect the user. Therefore, when a rope access technician is to be in tension or suspension, there should be at least two independently anchored lines, one primarily as a means of access, egress and support (the working line) and the other as additional back-up security (the safety line).

*NOTE* Where appropriate, the safety line may be substituted by other forms of back-up security, which should equal or better the performance of the one it replaces.

**1.4.2.5.2** The connection of a rope access technician to the rope access system or other personal fall protection system and disconnection from it should be made in an area where there is no risk of a fall from a height.

**1.4.2.5.3** The rope access technician should be connected to both the working line and the safety line via a harness, which may be an appropriate sit harness or an appropriate full-body harness. The same point on the harness may be used to connect the working line and the safety line to it.

**1.4.2.5.4** The primary connection to the rope access technician of both the working line and the safety line should always be via the harness, even if a work seat is being used.

**1.4.2.5.5** Steps should be taken to ensure a rope access technician is unable to descend inadvertently off the end of the working line or safety line and that, if the intention is to exit from them at the bottom, the anchor lines are long enough to do so.

**1.4.2.5.6** An efficient communication system should be established between all rope access technicians in the team and, where necessary, third parties, e.g. the control room, if offshore.

**1.4.2.5.7** Rope access systems should be planned to avoid falls. In the unlikely event of a fall, the impact load on a rope access technician should never be greater than 6 kN.

*NOTE* Potential impact loads can be reduced by keeping fall distances to a minimum, e.g. by positioning the back-up device high.

**1.4.2.5.8** The distance and consequences of any potential fall should always be minimized. No potential fall should allow the rope access technician to impact with the ground. All practicable steps should be taken to avoid the possibility of impacting with the structure, natural feature or obstructions in a way likely to cause injury.

**1.4.2.5.9** Rope access technicians should work in teams of no fewer than two, one of whom should be a Level 3 rope access safety supervisor.

*NOTE* There are many situations that require more than a two-person rope access team, depending, for example, on the nature of the work; site conditions; competency of the work team; potential rescue scenarios.

#### **1.4.2.6 Exclusion zones**

Exclusion zones should be established, as appropriate, to protect against falls where rope access technicians need to attach to the rope access system, e.g. an unprotected edge; to protect against falling objects from above; to protect people below the area of rope access operations and to protect against unauthorized persons entering the work area(s). Exclusion zones may also be required for reasons other than fall protection, e.g. to protect against exposure to: radiation; radio waves, such as those emitted by mobile phone antennae; areas of high temperature; chemical pollution. Exclusion zones may be necessary at several levels, e.g. above anchor level; at anchor level; at intermediate areas; at ground level.

#### **1.4.2.7 Emergency procedures**

**1.4.2.7.1** There should be suitable arrangements in place at every worksite to provide rapid workmate rescue/retrieval. These should include an appropriate site-specific plan, together with equipment, rigging and anchors of adequate strength for workmate retrieval.

**1.4.2.7.2** A rope access technician should endeavour always to be in a position such that, in the event of an incident, he/she would be able to rescue him/herself, or to be rescued quickly and efficiently by the work team or by a dedicated on-site rescue team.

#### **1.4.2.8 Expanded techniques**

Rope access techniques and equipment can be expanded to encompass traversing, aid climbing, lead climbing and other forms of harness-based access. Some of these techniques could put rope access technicians at risk of a fall. Techniques that could result in a fall should be used only after specific hazard identification and risk assessment and the appropriate choice of personal fall protection equipment. Only specifically trained and competent rope access technicians should engage in these types of rope-based access work. See **Part 3, Annex L**.

#### **1.4.3 Quality and safety controls**

**1.4.3.1** IRATA International full and probationary member companies, i.e. operator and trainer companies, are required to have competent rope access management and to provide a company-nominated person to be the main contact point between the company and IRATA International for matters relating to IRATA International safety training, this code of practice and other relevant IRATA International documentation. This system provides the best method for communication between the member company and the IRATA International office, executive committee, technical sub-committees, technical officer and executive staff.

**1.4.3.2** IRATA International operator member companies, which provide operational services, are subject to an initial probationary audit to check both technical and quality assurance aspects of procedures and equipment before being accepted as probationary members. After a minimum of one year, they are eligible for another audit before acceptance as full operator members. This audit concentrates on evidence of work completed to verify compliance with IRATA International requirements. Subsequently, member companies are re-audited every three years to ensure they maintain standards. The audits of each member company are undertaken by IRATA approved independent auditors. Member companies are also required to conduct internal audits at planned intervals to determine whether their arrangements conform to this code of practice (all relevant Parts) and any other IRATA International requirements, and that they are effectively implemented and managed.

**1.4.3.3** Audit programmes are planned, taking into account the size and complexity of the company, the status and importance of its processes, the hazards and risks associated with its operations and the results of previous audits. The audit objective, scope and criteria of each audit are determined. Records of the audits and their results are maintained and are subject to inspection by IRATA International. Member companies are responsible for ensuring that any necessary corrections, corrective and preventive actions are taken without undue delay to eliminate detected and potential non-conformities and their causes.

**1.4.3.4** IRATA International trainer member companies are subject to the same audit regime as operator member companies. Only IRATA International trainer member companies are authorised to deliver training to the IRATA International syllabus and to register candidates for IRATA International qualifications.

**1.4.3.5** All IRATA International training is controlled by IRATA International Level 3 trainers at training venues that have to meet specified requirements. All candidates are assessed by IRATA International independent assessors.

**1.4.3.6** All rope access work carried out by IRATA International operator member companies is undertaken by IRATA International trained and qualified rope access technicians working to the member company's operational procedures, which are based on this code of practice.

**1.4.3.7** There are three levels (grades) of rope access technician: Level 1, Level 2 and Level 3, the third level being the highest. All worksites operated by IRATA International member companies have at least one IRATA Level 3 rope access safety supervisor on site as the person responsible for the safety of the rope access systems and the Level 1 and Level 2 rope access technicians who work under their supervision. An IRATA International rope access team consists of at least two rope access technicians, one of whom has to be an IRATA International Level 3 rope access safety supervisor. Lone working is not allowed.

**1.4.3.8** IRATA International rope access safety supervisors are trained in first aid and are required to hold an in-date qualification.

**1.4.3.9** IRATA International full and probationary member companies are required to record all hours worked on ropes, incidents and dangerous occurrences and to provide quarterly work and safety statistics to the IRATA International office. The information is used by a nominated independent expert to compile a yearly report, the IRATA International *Work and Safety Analysis*, which highlights trends and provides recommendations for changes to working practices. This provides statistics upon which IRATA International can justify its claim that using an IRATA International member company allows a client to have the assurance that they are using the safest providers of rope access services.

**1.4.3.10** To provide a quick response to an incident that could have implications for other member companies and their clients, IRATA International has established a system to notify all members of such incidents and appropriate action that should be taken.

**1.4.3.11** IRATA International requires all safety method statements to include a rescue plan.

**1.4.3.12** IRATA International member companies are required to operate a management system for equipment certification, traceability and inspection in accordance with this code of practice and relevant national regulations.

**1.4.3.13** IRATA International makes a significant contribution to the development of safe techniques for work at height through a number of committees that provide the member companies with expert advice. These include committees for health, safety and equipment, training and auditing.

**1.4.3.14** IRATA International member companies are required to have an appropriate representative attend at least one general meeting or other formally convened meeting of the association, e.g. Training Committee; Health and Safety Committee; Equipment and Standards Committee; Regional Advisory Committee, within each 12 calendar-month period. Member companies are encouraged to participate in the many activities of the association, e.g. the above committees, thereby providing an unparalleled international consensus on the future direction of the rope access industry.



# **IRATA International code of practice for industrial rope access**

## **Part 2: Detailed guidance**

**July 2014**

The first edition of Part 2 was published in January 2010.  
The second edition was published in March 2013 plus amendments in March and September 2013.  
This third edition was published in July 2014.

Amendments issued since publication in July 2014

Amd. No	Date	Text affected

Published by:

IRATA International  
First Floor, Unit 3  
Eurogate Business Park  
Ashford  
Kent  
TN24 8XW  
England

Tel: +44 (0)1233 754600

Email: [info@irata.org](mailto:info@irata.org)

Website: [www.irata.org](http://www.irata.org)

Copyright © IRATA International 2014

ISBN: 978-0-9544993-4-1



## Contents

Introduction.....	4
2.1 General.....	4
2.2 Planning and management .....	6
2.2.1 Objective.....	6
2.2.2 Planning.....	6
2.2.3 Pre-work analysis .....	6
2.2.4 Risk assessment .....	7
2.2.5 Safety method statements.....	8
2.2.6 Procedures and personnel to be in place before work begins .....	8
2.2.6.1 Procedures.....	8
2.2.6.2 Personnel .....	9
2.2.7 Management and supervision of the rope access site.....	9
2.3 Selection of rope access technicians.....	10
2.3.1 General.....	10
2.3.2 Experience, attitude and aptitude.....	10
2.4 Competence.....	12
2.5 Training .....	13
2.5.1 General.....	13
2.5.2 IRATA International training, assessment and certification .....	13
2.5.3 Additional skill levels .....	14
2.5.3.1 General.....	14
2.5.3.2 Trainers and Instructors .....	15
2.5.3.3 Assessors (Level A/3) .....	15
2.5.3.4 Auditors .....	16
2.6 Rope access managers, rope access safety supervisors and other supervisory/management items .....	18
2.6.1 Rope access managers.....	18
2.6.2 Rope access safety supervisors.....	18
2.6.3 Other supervisory/management items .....	19
2.6.3.1 Disciplined working.....	19
2.6.3.2 Access by non-IRATA International qualified personnel.....	19
2.6.3.3 Company nominated person (the technical contact).....	19
2.7 Selection of equipment.....	21
2.7.1 General.....	21
2.7.1.1 Application-specific assessment .....	21
2.7.1.2 Legal requirements.....	21
2.7.1.3 Standards .....	21
2.7.1.4 Load ratings/minimum static strength .....	22
2.7.1.5 Equipment for work restraint, work positioning and fall arrest .....	22
2.7.1.5.1 Work restraint (travel restriction) equipment .....	22
2.7.1.6 Limits of equipment use and compatibility .....	23
2.7.1.7 Knowledge of equipment.....	23
2.7.2 Ropes (e.g. for anchor lines) .....	23
2.7.3 Harnesses .....	25
2.7.4 Connectors .....	26
2.7.5 Descending devices .....	27
2.7.6 Ascending devices .....	29
2.7.7 Back-up devices .....	30
2.7.8 Lanyards and slings .....	31
2.7.8.1 General.....	31
2.7.8.2 Device lanyards and anchor lanyards.....	32

IRATA International code of practice for industrial rope access  
Part 2 of 5: Detailed guidance

2.7.8.3	Anchor slings .....	32
2.7.8.4	Selection criteria for device lanyards, anchor lanyards and anchor slings .....	33
2.7.8.5	Other information on lanyards .....	33
2.7.9	Anchors .....	35
2.7.10	Protectors for anchor lines .....	37
2.7.11	Work seats.....	37
2.7.12	Helmets .....	38
2.7.13	Pulleys .....	38
2.7.14	Clothing and protective equipment.....	38
2.8	Marking and traceability .....	40
2.9	Records .....	42
2.10	Inspection, care and maintenance of equipment .....	44
2.10.1	General procedures.....	44
2.10.2	Equipment manufactured from man-made fibres.....	45
2.10.3	Metal equipment.....	47
2.10.4	Protective helmets.....	48
2.10.5	Disinfection of equipment.....	48
2.10.6	Equipment exposed to a marine environment.....	48
2.10.7	Storage .....	48
2.10.8	Equipment withdrawn from service .....	48
2.10.9	Lifespan .....	49
2.10.10	Alterations to equipment.....	49
2.11	Primary rope access work methods.....	50
2.11.1	Double protection .....	50
2.11.2	The anchor system (anchors and anchor lines).....	52
2.11.3	Use of anchor lines.....	56
2.11.3.1	Rigging and de-rigging .....	56
2.11.3.2	Protection methods for anchor lines.....	59
2.11.4	Additional safety measures .....	60
2.11.5	The use of knots.....	62
2.11.6	Work teams .....	63
2.11.7	Pre-work checking.....	63
2.11.8	Exclusion zones.....	64
2.11.8.1	General.....	64
2.11.8.2	Protection of third parties .....	64
2.11.8.3	Anchor area exclusion zone .....	65
2.11.8.4	Working edge hazard zone .....	65
2.11.9	Communication.....	65
2.11.10	Welfare .....	66
2.11.11	Emergency procedures .....	67
2.11.12	Reporting of incidents and accidents .....	67
2.11.13	End of shifts.....	68
2.11.14	Termination of a job.....	68
2.11.15	Expanded techniques.....	68
Figure 2.1 — Example of the loading positions of a connector in a static strength test and the difference in use, e.g. when loaded with a wide webbing lanyard .....		28
Figure 2.2 — Illustration to show an example of an anchor sling and examples of different types of lanyard .....		34
Figure 2.3 — Example of a scaffold knot (often referred to as a barrel knot).....		34
Figure 2.4 — Examples of the increase in loading on anchors, anchor lines and anchor slings caused by an increase in the Y angle.....		36
Figure 2.5 — Typical arrangements in a rope access anchor system.....		51

Figure 2.6 — Typical arrangements in a rope access anchor system to achieve minimum strength recommendations..... 53

Figure 2.7 — Example of a lark’s-footed (choked) sling ..... 55

Figure 2.8 — Example of how the angle at a deviation anchor affects its loading ..... 56

Figure 2.9 — Example of a stopper knot for use at the end of anchor lines (in this example, half a double fisherman’s knot) ..... 58

Figure 2.10 — Example of the potential danger of snagged anchor lines ..... 61

Figure 2.11 — Examples of different types of exclusion zone ..... 66

Table 2.1 — Recommended minimum static strengths for connectors ..... 27

## Part 2: Detailed guidance

### Introduction

Part 2 builds on the principles and controls given in Part 1 and gives detailed guidance on how IRATA International provides a safe system of work.

This part should be read in conjunction with the other parts, in particular with Part 1 and relevant annexes in Part 3.

### 2.1 General

**2.1.1** All work at height should have a goal of no accidents, incidents or dangerous occurrences. It is essential, therefore, that the entire work project is operated as a safe system of work.

**2.1.2** There can be many different aspects to each work project that could influence the level of safety, e.g. the type of work to be carried out; site location; ease of access and egress; facilities for emergencies; interaction with other work going on at the site. All such potentially influencing factors should be taken into account, as each factor is likely to rely on the proper implementation of the others for a safe system of work to be achieved. These factors should be considered when determining whether rope access is an appropriate method of work. The rope access method and the rescue plan chosen initially may need to be modified when all factors have been considered.

**2.1.3** To achieve a safe system of work, there needs to be good planning and an effective management system, including appropriate supervision for both the overall site and for the safety of the rope access team.

**2.1.4** Different skills are required by rope access personnel, depending on their specific responsibility, i.e. manager, rope access safety supervisor and rope access technician. It is essential that each person has a skill level appropriate for the work to be undertaken and the environment in which they are likely to be working.

**2.1.5** Different work environments can present different levels of complexity or risk. Rope access methods can vary in their complexity due to the work environment but should be kept as simple as possible. The level of complexity and degree of risk influences the:

- a) planning, management and supervisory skills required;
- b) skill levels and experience required by the rope access technicians;
- c) choice of access method and equipment to be used.

**2.1.6** To help achieve a safe rope access system, the following essential subjects are covered in this code of practice, each in its own section or sections:

- a) planning and management, see **2.2**;
- b) selection, competence, training and supervision of rope access technicians, and appropriate composition of the team, see **2.3, 2.4, 2.5** and **2.6**;
- c) equipment selection, use and maintenance, see **2.7, 2.8, 2.9** and **2.10**;
- d) work methods, see **2.11**.

**2.1.7** Planning and management should take account of the legislation applicable where the work is being undertaken. Legislation varies from country to country and sometimes from region to

region. See **Part 4** for relevant national legislation for the UK. Legislation to be covered for other jurisdictions might include:

- a) work at height;
- b) manual handling;
- c) lifting;
- d) hazardous substances;
- e) personal protective equipment;
- f) incident reporting;
- g) first aid;
- h) control of noise;
- i) risk assessment (also known as job safety analysis; job hazard analysis);
- j) emergency procedures;
- k) plant, machinery and tools;
- l) confined spaces;
- m) electricity at work.

## **2.2 Planning and management**

### **2.2.1 Objective**

The primary objective behind the planning and management of rope access projects is to create a work environment that maximizes safety and minimizes the risk of error, possible incidents and injury, i.e. to provide a safe system of work.

### **2.2.2 Planning**

Before any rope access project is considered, a documented system should be in place to define or provide for at least the following:

- a) a clear line-management structure showing the responsibilities of personnel;
- b) a safety management policy, including procedures for effective internal audit monitoring and review, which should incorporate corrective and preventative actions to be taken, and procedures adequate to control the work;
- c) appropriate insurance, e.g. for the rope access technicians, public liability and other aspects relevant to the worksite;
- d) a risk assessment, which covers identification of hazards, assessment of the likelihood of an incident occurring and control measures to minimize the risk;
- e) specific planning of the project, including the safety method statement and rescue plan;
- f) prior agreement of operating procedures if rope access technicians from another company are working in the same team;
- g) confirmation that the rope access safety supervisor has the company's authority to act whenever necessary to ensure the safety of the rope access technicians, the public and the worksite;
- h) the selection of competent personnel;
- i) records of the competence of personnel, e.g. skill levels and experience;
- j) how proper communication of relevant information to all staff is to be provided;
- k) the selection of appropriate equipment;
- l) a list of equipment with inspection records;
- m) specific procedures to deal with hazardous materials, machinery, fixtures and tools, and environmental hazards.

### **2.2.3 Pre-work analysis**

A pre-work analysis should be carried out before rope access work is undertaken on a project to confirm that rope access is a suitable method and to ensure control systems are in place to allow the work to be carried out safely. Examples of typical points to be covered are:

- a) how the work area can be accessed and exited safely;
- b) the ease and degree of safety with which a rope access technician will be able to use tools and equipment while suspended;

- c) whether there might be a risk of loose materials or equipment falling onto people below;
- d) whether the duration of the work in a location might put the rope access technician at risk, e.g. prolonged exposure to extremes of heat or cold;
- e) whether rope access technicians could be rescued quickly from any potential position in which they might find themselves.

#### **2.2.4 Risk assessment**

**2.2.4.1** Once it has been decided that rope access is a suitable method to carry out the intended task, employers should review carefully the procedures to be followed for carrying out the work. They should identify any hazards and examine how they can be removed or, if this is not possible, how the risk can be reduced to an acceptable level. This is determined by carrying out a risk assessment, which is also known as a job safety analysis (JSA). For more information on risk assessment, see **Part 3, Annex A**.

**2.2.4.2** The detail provided in the risk assessment should be in proportion to the risk. Once the risks are assessed and taken into account, insignificant risks can then often be ignored, unless the type of work to be carried out would increase those risks.

**2.2.4.3** Hazard identification should comprise identification of anything with the potential to cause harm, for example:

- a) power cables, which could pose a high risk of electric shock;
- b) any hazard placing the public or other workers at risk, in particular, persons working on the ground on to which debris or tools could be dropped;
- c) the presence of other trades;
- d) the tools being used;
- e) moving or carrying heavy machinery, tools or other equipment;
- f) repetitive use of tools or equipment;
- g) the unavailability of anchor points of suitable size, shape and strength for the proposed access method and work to be carried out;
- h) sharp or rough edges on which the anchor lines could be cut or abraded;
- i) hot surfaces or hot work that could damage anchor lines or injure rope access technicians;
- j) hazardous substances, e.g. toxic gases, acids, asbestos;
- k) radio waves, radiation;
- l) adverse weather conditions.

**2.2.4.4** After the hazards have been identified, the risk assessment should continue with a careful study of all the hazards identified, to determine the level of risk posed by each. As a first step, wherever possible, hazards should be eliminated. If this is not possible, precautions should be taken to minimize the likelihood of persons being harmed. Thus, the chance of an incident occurring in the first place is reduced. In addition, the undesirable possibility of having to deal with an incident and its consequences is also reduced.

**2.2.4.5** The hazard identification and risk assessment should be site specific. They should be documented and should cover all aspects of the work to be undertaken. The document(s) should be

available to personnel working on-site and should be regularly reviewed formally by them during the course of the work, to take account of changing circumstances, e.g. weather conditions and other work being carried out. Operations such as oil platforms, refineries, power stations and railways have a formal written permit-to-work system to address hazards, by requiring certain precautions to be taken. Examples are: electrical isolations; restriction of other work; communication requirements; specified personal protective equipment.

**2.2.4.6** The risk assessment should include detailed consideration of foreseeable emergency scenarios and planning as to how any rescue would be carried out.

## **2.2.5 Safety method statements**

**2.2.5.1** Planning should not only include the selection of appropriate working methods, equipment and competent personnel but should also include the preparation of a safety method statement. Safety method statements are an effective way of producing an action plan for a safe system of work and are useful in bringing together the assessments of the various hazards that may arise on a job.

**2.2.5.2** The safety method statement should set out working procedures to be followed for each particular job. All safety method statements should include a specific rescue plan, e.g. rigging for rescue.

**2.2.5.3** In cases where types of jobs are similar, the safety method statements could be identical and may, therefore, be in the form of a general document. However, separate safety method statements may be necessary for each particular aspect of the job. Where the work includes the use of hazardous tools (e.g. welding torches, flame cutters, abrasive wheels), a more detailed safety method statement should be prepared. For advice on preparing a safety method statement, see **Part 3, Annex B**.

## **2.2.6 Procedures and personnel to be in place before work begins**

### **2.2.6.1 Procedures**

Before work begins, at least the following procedures should be in place to enable a rope access team to carry out a task safely:

- a) a documented system of work;
- b) a documented safety method statement;
- c) permits to work, where necessary;
- d) site induction requirements;
- e) hand-over procedures, e.g. between shift changes or site contractors;
- f) site-specific documentation, e.g. rope access technicians' log books; end of shift documentation; hours worked/accident/incident report forms; work log; equipment user instructions. For a recommended list of information to be kept on site, see **Part 3, Annex N**;
- g) worksite facilities, e.g. for resting; for emergency washing; showers; toilets;
- h) where appropriate, a documented site inspection, including suitable provision for anchors, and a rigging/rescue plan;
- i) planning for emergencies, e.g. fire; entrapment (including rescue), including any equipment required;
- j) protection of third parties, e.g. exclusion zones; barriers; warning signs.



### **2.2.6.2 Personnel**

Before work begins, there should be at least the following personnel in place to enable a rope access team to carry out a task safely:

- a) a rope access manager with overall responsibility for the rope access site;
- b) an appropriate number of trained, assessed and suitably equipped rope access technicians, with a minimum of two, one of which is a Level 3 rope access safety supervisor;

*NOTE It may be necessary for there to be more than one Level 3 rope access safety supervisor, depending on the number of rope access technicians on site.*

- c) additional assisting personnel as required, e.g. sentries; traffic monitors.

### **2.2.7 Management and supervision of the rope access site**

**2.2.7.1** Rope access worksites should be properly managed and supervised to ensure the safety of those involved in the rope access project.

**2.2.7.2** There should be a rope access manager, who is responsible for determining that rope access is an appropriate method of work and for defining, planning, implementing and reviewing the operation of a safe system of work.

**2.2.7.3** Worksites using rope access require the supervision of rope access safety and of the work project itself. These two types of supervision may be the responsibility of different people or the same person. This code of practice covers only the supervision of rope access safety.

**2.2.7.4** For more information on rope access managers and rope access safety supervisors, see **2.6**.

## **2.3 Selection of rope access technicians**

### **2.3.1 General**

**2.3.1.1** To work at height safely requires personnel to have an appropriate attitude, aptitude, physical capability and training. Therefore, some form of screening is required to assess properly all prospective employees.

**2.3.1.2** It is important that rope access technicians can be relied upon to behave in a sensible and responsible manner.

**2.3.1.3** Rope access technicians should be physically fit and free from any disability that might prevent them from working safely at height. Contra-indications include:

- a) alcohol or drug dependence;
- b) diabetes; high or low blood pressure;
- c) epilepsy, fits, blackouts;
- d) fear of heights;
- e) vertigo/giddiness/difficulty with balance;
- f) heart disease/chest pain;
- g) high or low blood pressure;
- h) impaired limb function;
- i) musculoskeletal issues, e.g. a bad back;
- j) obesity;
- k) psychiatric illness.

**2.3.1.4** It is the responsibility of the trainee or their employer to ensure that the trainee is physically and medically fit to undergo rope access training.

**2.3.1.5** Employees have a responsibility to their employers and their work colleagues to notify any changes in their physical and medical condition which may affect their work. This includes the effects of alcohol or drugs.

**2.3.1.6** Rope access technicians should be given the opportunity not to work at height if they do not feel fit enough to do so.

### **2.3.2 Experience, attitude and aptitude**

**2.3.2.1** All persons working at height need to have at least elementary background awareness of different fall protection methods, e.g. fall arrest; work restraint; safety net systems; air bags; mobile elevating work platforms, in addition to that required for rope access.

**2.3.2.2** To assess whether a person is suitable to work in rope access requires detailed consideration of their previous experience. References should be taken up to verify claimed experience and levels of competence.

**2.3.2.3** Employers should also consider relevant trade experience and skills, to ensure safe use of tools and equipment.

**2.3.2.4** Employers should seek to ensure that rope access technicians, including trainees, have a suitable attitude and aptitude in addition to their IRATA International qualification. These include:

- a) a head for heights;
- b) a natural ability or potential for rope access work;
- c) the ability to work in a team;
- d) a responsible attitude to safety;
- e) a willingness to improve their skills;
- f) a professional standard of behaviour.

**2.3.2.5** Consideration should be given to the composition of a rope access team, as teamwork, work skills, rescue capability and the correct level of supervision are essential.

**2.3.2.6** The selection of team members should take into account the specific tasks to be undertaken.

## 2.4 Competence

**2.4.1** Rope access work can only be carried out in a reliably safe manner where people are competent. To be considered competent, a rope access technician needs to have sufficient professional or technical training, knowledge, actual experience and authority to enable them to:

- a) carry out their assigned duties at the level of responsibility allocated to them;
- b) understand potential hazards related to the work under consideration and be able to carry out appropriate workmate rescue procedures;
- c) detect technical defects or omissions in their work and equipment, recognize implications for health and safety caused by such defects or omissions, and be able to specify a remedial action to mitigate those implications.

**2.4.2** Rope access technicians should have adequate skill and experience to:

- a) understand the limitations of their level of training with regard to work practices;
- b) understand the various uses of the equipment they use and its limitations;
- c) select equipment correctly;
- d) use the equipment properly;
- e) inspect their equipment;
- f) maintain and store the equipment they use.

**2.4.3** It is essential that rope access personnel maintain their knowledge of industry best practices, equipment developments and current legislation.

## 2.5 Training

*NOTE* Wherever the terms *Level 1*, *Level 2*, *Level 3*, *assessor*, *auditor* and *trainer* are used, these refer to IRATA International qualifications, whether it states so or not.

### 2.5.1 General

**2.5.1.1** As a general rule, training should be either provided or monitored by an expert external organization or person, to ensure that the standard is to an externally certificated level. Training routes should be clearly defined. Assessments should only be carried out by assessors who are commercially independent of the candidate, the candidate's company and the organization providing the training.

**2.5.1.2** Procedures should be in place to document the work at height and rope access experience of rope access technicians, and to allow certification bodies to verify the rope access technicians' experience. Documented experience is also useful for prospective employers to enable them to judge the suitability of personnel for various tasks.

### 2.5.2 IRATA International training, assessment and certification

**2.5.2.1** IRATA International has a formal training syllabus, assessment and certification scheme, and grading structure, which meets the criteria set out in **2.5.1.1** and **2.5.1.2**. All IRATA International members are obliged to use this scheme. Rope access technicians are grouped into three technical grades, depending upon their experience and level of assessment as set out in the publication *IRATA International training, assessment and certification scheme for personnel engaged in industrial rope access methods* (TACS). The three technical grades are:

a) **Level 1**

This is a rope access technician who is able to perform a specified range of rope access tasks under the supervision of a Level 3 rope access safety supervisor.

b) **Level 2**

This is an experienced rope access technician who has Level 1 skills plus more complex rigging, rescue and rope access skills, under the supervision of a Level 3 rope access safety supervisor.

c) **Level 3**

This is a rope access technician who is able to demonstrate the skills and knowledge required of Levels 1 and 2; is conversant with relevant work techniques and legislation; has an extensive knowledge of advanced rigging and rescue techniques; holds an appropriate and current first aid certificate and has knowledge of the IRATA International training, assessment and certification scheme. Subject to a Level 3 having the necessary supervisory skills, he/she can become a rope access safety supervisor with responsibility for rope access safety in work projects: see **2.5.2.6** and **2.6**.

**2.5.2.2** To become an IRATA International Level 1 rope access technician, candidates have to undertake an IRATA International approved training course of a minimum of four days followed by a one-day assessment by an independent IRATA International assessor. Once the training course and assessment have been satisfactorily completed, the person may then be allowed to work using rope access techniques, although this has to be under close supervision.

**2.5.2.3** Special precautions should be taken for newly qualified rope access technicians. These include only gradually introducing them to the work and initially only allowing them to carry out the most straightforward operations, under the direct control of a rope access safety supervisor. As the rope access safety supervisor becomes satisfied that they are fit to do so, the new rope access technicians should then be allowed to progress gradually to more complex work, although still under close supervision. At this stage, the rope access safety supervisor should check that all items of the

inexperienced rope access technician's suspension equipment are correctly secured before they are allowed to start work.

**2.5.2.4** Rope access technicians are in the learning process for some time after completing their basic training. They should, therefore, be continuously assessed by the rope access safety supervisor and not allowed to work without close supervision until the rope access safety supervisor is satisfied that they have achieved a suitable level of competency. This would be when they had demonstrated that they had suitable knowledge and experience to carry out the full range of tasks that they were likely to encounter in a safe and effective manner, and were capable of acting properly within the limits of their level of competency and in any emergency that might reasonably arise.

**2.5.2.5** To achieve the next level, i.e. Level 2 rope access technician, where the person could be regarded as an experienced worker, Level 1 technicians have to log at least 1 000 working hours using rope access techniques and have worked for a minimum of one year at Level 1. They have then to undergo a minimum of four days further training plus an assessment by an independent IRATA International assessor.

**2.5.2.6** Before a Level 2 can become a Level 3 rope access technician, a minimum of one year at Level 2 and at least a further 1 000 working hours using rope access techniques have to be logged, i.e. a combined minimum total of two years and 2 000 hours at Level 1 and Level 2. A minimum of four days of further training and then assessment by an independent IRATA International assessor are required. This is particularly to ensure that the person has the necessary technical skills for this level and may be ready to prove their competence to supervise rope access safety. It is the employer's responsibility to ensure that Level 3s are competent to supervise. See **2.6** for information on rope access safety supervisors.

**2.5.2.7** It is essential that employers ensure their employees are competent. To ensure that all levels of rope access technician maintain their skill level, a further training course followed by reassessment is required every three years.

**2.5.2.8** Due to the aptitude and mental conditioning that are needed for exposure to height, rope access technicians who have not been engaged in rope access work for six months or more are required to attend a suitable refresher course before being allowed to work in this manner. This may be either a refresher course or a full course at the appropriate level. The refresher courses should include all the techniques covered during Level 1 training. For Level 2 and Level 3 rope access technicians, the refresher course should concentrate on rigging and rescue procedures (see the publication *IRATA International training, assessment and certification scheme for personnel engaged in industrial rope access methods* (TACS)).

**2.5.2.9** As part of on-going training, rescue procedures should be practised at regular intervals and before the start of any work in situations that are unfamiliar to any of the work team (see **2.11.11**).

**2.5.2.10** Rope access technicians are registered under the IRATA International training, assessment and certification scheme and are issued with a personal logbook that is used to document their work experience and any relevant training received. As detailed within the scheme, logbook entries should be countersigned by an IRATA International rope access safety supervisor. Employers taking on new rope access technicians should assess and, where necessary, verify the information contained in their logbooks to confirm suitability for the work to be undertaken (see **2.3.2**).

## **2.5.3 Additional skill levels**

### **2.5.3.1 General**

In addition to becoming a rope access safety supervisor, IRATA International Level 3 rope access technicians may specialize in up to four categories of additional skills. These are trainers, instructors, assessors and auditors.

### **2.5.3.2 Trainers and instructors**

**2.5.3.2.1** IRATA trainer member companies appoint suitable Level 3 rope access technicians to act as trainers, who are then employed to train applicants to the three rope access technician grades, i.e. Levels 1, 2 and 3.

**2.5.3.2.2** IRATA Level 3 rope access technicians with extensive training experience may gain additional certification as IRATA rope access instructors (Level 3/I).

**2.5.3.2.3** Level 1 and Level 2 rope access technicians may be engaged in training as assistants to a Level 3 rope access trainer or Level 3 rope access instructor. Such Level 2 assistant trainers may register with IRATA as trainee instructors and begin to log their training experience, but may not teach (or log) Level 2 or Level 3 topics until they are qualified at IRATA Level 3.

*NOTE* The qualifications of the rope access technicians carrying out training (i.e. trainer, assistant trainer, instructor, assistant instructor) and the qualification levels of the trainees determine the maximum number of trainees allowed to be trained in any one group at any one time.

**2.5.3.2.4** It should be noted that only IRATA qualified rope access technicians are allowed to assist in training courses.

**2.5.3.2.5** Trainee instructors are required to log at least 400 hours of training experience before they are eligible to apply for full instructor status.

**2.5.3.2.6** Rope access technicians wishing to become trainee instructors first need to gain the sponsorship of an IRATA trainer member company.

**2.5.3.2.7** For details of trainer and instructor requirements, see the publication *IRATA International training, assessment and certification scheme for personnel engaged in industrial rope access methods*.

### **2.5.3.3 Assessors (Level A/3)**

**2.5.3.3.1** IRATA International appoints assessors, who are then employed by IRATA International trainer member companies to carry out independent assessments of rope access technicians who have completed an IRATA International training course operated by an IRATA International member company.

**2.5.3.3.2** The primary rôle of the assessor is to ensure that each candidate demonstrates performance of the required tasks in a safe manner, in accordance with the current edition of the *IRATA International training, assessment and certification scheme for personnel engaged in industrial rope access methods* and this code of practice.

**2.5.3.3.3** Assessors are responsible for rope access assessment to Levels 1, 2 and 3.

**2.5.3.3.4** To be eligible to become an assessor, applicants are required to have been working as a Level 3 rope access technician for a minimum of six years.

**2.5.3.3.5** Assessors are appointed at the discretion of the Executive Committee on the recommendation of the Training Committee.

**2.5.3.3.6** Applicants are required to provide credentials at the time of application and are expected to retain the necessary knowledge, skills and physical fitness required during the full period of the appointment. This includes the Level 3 qualification.

**2.5.3.3.7** Once appointed, assessors may conduct assessments on behalf of IRATA International only in conformance with the current editions of the *IRATA International training, assessment and*

*certification scheme for personnel engaged in industrial rope access methods*, this code of practice and any amendments published on the IRATA International website.

**2.5.3.3.8** IRATA International assessors are required to abide by the IRATA International document *Requirements and guidance for IRATA assessors and assessments*.

**2.5.3.3.9** To retain their status, assessors are required to:

- a) attend at least one assessors' workshop per year;
- b) assess twenty candidates per year (unless a lower figure has been previously agreed), covering all levels of rope access technician;
- c) hold valid Level 3, first-aid and insurance certificates.

#### **2.5.3.4 Auditors**

IRATA International appoints auditors to carry out audits of companies applying for membership of IRATA International and re-audits, which are required every three years. Auditors undergo external auditor training.



This page is intentionally blank

## **2.6 Rope access managers, rope access safety supervisors and other supervisory/management items**

### **2.6.1 Rope access managers**

**2.6.1.1** Rope access managers are responsible for determining that rope access is an appropriate method of work, and for defining, planning, implementing and reviewing the operation of a safe system of work. They should have:

- a) competence and experience for the work being managed;
- b) the ability to communicate requirements to rope access safety supervisors;
- c) the ability to create, implement and review control systems, and be able to assess which control measures are appropriate for each project;
- d) the ability to ensure correct operation of the rope access management system.

**2.6.1.2** Rope access managers have a duty to ensure that rope access safety supervisors and other rope access technicians are competent for the particular rope access task in hand.

**2.6.1.3** Employers should ensure that rope access managers have the necessary management skills before they are given such a rôle. Some form of training in management plus an assessment is recommended. There should be a clearly defined reporting system to senior management.

*NOTE In a small organization, the senior manager, rope access manager and rope access safety supervisor might be the same person.*

### **2.6.2 Rope access safety supervisors**

**2.6.2.1** This code of practice covers only the supervision of rope access safety and not the work project itself.

**2.6.2.2** The rope access safety supervisor's rôle is to ensure that the work and the workers proceed in accordance with this code of practice, in the manner set out in the documentation for the work project and with the aim of no accidents, no waste and no defects (known as zero targeting).

**2.6.2.3** It is essential that rope access safety supervisors have the experience and competence to supervise the rope access work and any potential rescue for each rope access project under their supervision.

**2.6.2.4** Under the IRATA International scheme, only Level 3 rope access technicians are permitted to be rope access safety supervisors. Employers should ensure that Level 3s have the necessary supervisory skills before they are given such a rôle, as rope access technical skills alone are no assurance that a Level 3 is competent to supervise. Some form of training in supervision plus an assessment is recommended.

**2.6.2.5** Level 3 rope access safety supervisors require:

- a) the experience and competence to supervise the rope access work and any potential rescue for each rope access project under their supervision;
- b) the ability to communicate to rope access technicians the rope access safety requirements for the project and to manage day-to-day problems on the site;
- c) leadership abilities appropriate to the work team;

- d) the ability to monitor closely both worksite and personnel for rope access safety and to be able to identify any shortfalls in the required competence of those personnel;
- e) a thorough knowledge of hazard identification and risk assessment, and methods of site management;
- f) the ability to understand and implement the content of safety method statements;
- g) the ability to complete and maintain relevant documentation;
- h) the authority to make decisions to ensure the safety of rope access technicians, the public and the rope access worksite, e.g. the withdrawal of equipment from service if thought to be inappropriate or unsafe.

**2.6.2.6** Different levels of rope access safety supervisor skills may be required for different access tasks, dependent upon the precise nature of the work. This could apply when the work task is unfamiliar, complex or possibly hazardous, e.g. working in confined spaces; working with chemicals; working with potentially dangerous tools, and in relation to the ability to provide adequate cover for emergencies.

**2.6.2.7** In every case, the level of supervision should be appropriate to the particular work situation and the numbers and skills of the work team.

**2.6.2.8** The rope access safety supervisor should ensure every rope access technician and other members of the work team under his/her supervision understand the work procedures prior to work commencing.

**2.6.2.9** Rope access safety supervisors should be familiar with their work environment, the working conditions and practices, and, in particular, the essential liaison necessary with other workplace personnel.

**2.6.2.10** There should be a clearly defined reporting system to the rope access manager.

### **2.6.3 Other supervisory/management items**

#### **2.6.3.1 Disciplined working**

As part of their duties to maintain a safe place of work, employers should control any tendency of employees to work in an undisciplined manner by recording this in their personal logbooks and should not cancel any adverse comments until completely satisfied that there would be no recurrence.

#### **2.6.3.2 Access by non-IRATA International qualified personnel**

The person responsible for the work site should only allow rope access methods to be carried out by experienced rope access technicians, trained and assessed to IRATA International standards. This includes any representative of the client. However, occasions may arise where a client's representatives or other people not employed by the contractor need to inspect the work. Both the contractor and the client should arrange systems to ensure that such persons will be able to do this safely. This could be done, for example, by providing additional top-rope protection (i.e. protect the person with an additional safety line from above). In addition, the rope access safety supervisor should check personally that all items of such a person's suspension equipment are correctly secured and of a suitable standard and condition. They should then supervise them throughout the ascent or descent as though they were new trainees.

#### **2.6.3.3 Company nominated person (the technical contact)**

Companies employing rope access techniques should nominate one person to be the main contact point between IRATA International and the company for matters relating to IRATA International safety training, this code of practice and other IRATA International documentation. This *company nominated*

*person*, also known as the *technical contact*, should be suitably knowledgeable, experienced and qualified in such matters or have access to a person or persons within the company who are.

## 2.7 Selection of equipment

### 2.7.1 General

#### 2.7.1.1 Application-specific assessment

An assessment should be carried out before each job to select the most appropriate equipment to be used. Where the suitability of a piece of equipment is unknown, it should be thoroughly evaluated and/or tested before it is used. Rope access equipment should be selected only for its intended purpose as specified by the manufacturer. If equipment is to be used for other applications, confirmation should be obtained from the manufacturer that it is acceptable to do so and any caveats should be taken into account. The assessment should also pay special attention to the probability and consequences of misuse of equipment, taking into account any known incidents, e.g. as detailed in IRATA International safety bulletins. The selection and purchase of equipment should be carried out by, or approved by, a competent person, who has sufficient knowledge of the technical specifications required.

#### 2.7.1.2 Legal requirements

**2.7.1.2.1** Equipment should be chosen which satisfies legal requirements in the country of use. These requirements vary from country to country and sometimes from region to region. See **Part 4** for relevant national legislation.

**2.7.1.2.2** Generally, it is not a legal requirement for equipment to conform to standards. However, it should be noted that they may be used to support the law.

#### 2.7.1.3 Standards

**2.7.1.3.1** Generally, equipment should be selected that conforms to national or international standards. It is important that the selected standards are relevant to the intended use. For a list of standards referred to in this code of practice, see **Part 3, Annex C**.

**2.7.1.3.2** For many years, workplace standards did not cover much of the equipment used in rope access and equipment meeting standards for mountaineering and caving was often used. There are now workplace standards that cover almost all personal fall protection equipment used in rope access. Equipment conforming to these standards should be chosen, wherever possible.

**2.7.1.3.3** Equipment that conforms to an appropriate standard is important, but is not the sole factor in the selection criteria. Sometimes, a standard might not cover all the requirements advisable for rope access use and equipment with the desired features might render it out of conformance with the standard. In some cases, equipment that conforms to a combination of requirements from more than one standard, e.g. a hybrid of two standards, might be more appropriate. The equipment manufacturer or his authorized representative should be able to provide information.

**2.7.1.3.4** Similarly, just because a piece of equipment does not claim conformity to a particular standard, it does not necessarily mean that it is unfit for use. For example, when a revision, i.e. an update, of a standard is published, it does not necessarily mean that equipment that conforms to the old version can no longer be used. This would only be the case if serious safety issues had been detected in products conforming to these earlier standards and/or in the standards themselves. However, if a product has been tested to the most recent version of an appropriate standard, it should give some confidence that it will be safe for its intended use. The same points apply to equipment not conforming to local legislative requirements, e.g. CE marking; OSHA.

**2.7.1.3.5** Manufacturers should not claim product conformity to draft standards but, in cases where there is no appropriate standard of any kind, this is sometimes the only feasible option. Purchasers should be aware that a draft standard could change.

**2.7.1.3.6** If there is any doubt about whether or not a particular standard is relevant to the intended use, guidance should be sought from the manufacturer of the equipment or his authorized representative.

#### **2.7.1.4 Load ratings/minimum static strength**

**2.7.1.4.1** Manufacturers' specifications for the permissible loading of equipment should be taken as the starting point for the selection of equipment. Some equipment, e.g. descending devices; back-up devices, may be supplied with maximum and/or minimum rated loads ( $RL_{MAX}$  and  $RL_{MIN}$ ). Other equipment may be supplied with different types of load ratings, e.g. a safe working load (SWL); working load limit (WLL). These are sometimes in addition to the minimum static strength provided, e.g. connectors, and sometimes in place of it. Most personal fall protection equipment used in rope access work, such as low-stretch ropes, harnesses and ascending devices, is tested using the minimum static strength specified in the relevant standards. Dynamic rope is supplied with a statement of the number of dynamic falls held during type testing.

*NOTE It is reiterated that, apart from safe working loads, working load limits and minimum and maximum rated loads, static strength requirements in standards are usually minimums. Equipment with a higher static strength is likely to provide a higher level of protection.*

**2.7.1.4.2** Some countries or regions, e.g. USA, have statutory minimum strength requirements for equipment, which might be higher than those given in this code of practice. Purchasers of equipment should check their local legislation.

#### **2.7.1.5 Equipment for work restraint, work positioning and fall arrest**

##### **2.7.1.5.1 Work restraint (travel restriction) equipment**

If the objective is to restrict the user's travel so that access is not possible to zones where the risk of a fall from a height exists, work restraint equipment may be used. This could be fall arrest equipment, work positioning equipment, or even a simple belt and lanyard of limited length and strength. Different countries or states may have their own regulations with regard to what is acceptable. To ensure the user is working in restraint, there should be no fall hazards within reach of the user. For more information on work restraint, see **Annex L**.

##### **2.7.1.5.2 Work positioning equipment**

If the planned method of work is for the user to be in a partly or entirely supported position, as is the normal case for rope access work, then work positioning equipment may be chosen. In addition to its primary function of providing support, this equipment is designed to be strong enough to arrest a free fall of limited distance and force but will not meet the other essential requirements of a fall arrest system, unless combined with appropriate components. Information on limited free falls will be provided at some future date in Part 3. Work positioning harnesses for rope access work may be a sit harness or full body harness, dependent upon the precise nature of the work to be carried out. In work positioning, there should be minimal slack in the system, e.g. dynamic rope anchor lanyards used in horizontal aid climbing or with a horizontal traverse line should be attached above the rope access technician's harness attachment point in such a way as to ensure little or no slack, therefore minimizing the consequences of a fall. For more information on work positioning, see **Annex L**.

##### **2.7.1.5.3 Fall arrest equipment**

If the planned method of work is such that should the user lose controlled physical contact with the working surface there would be a significant free fall (outside the normal bounds of rope access, e.g. lead climbing, see **2.11.16**), it is necessary to choose fall arrest equipment. This includes an appropriate full body harness and a system that limits the impact load to an acceptable level. This level varies internationally between 4 kN and 8 kN. Maximum impact loads are usually controlled by the use of commercially made energy absorbers. For more information on fall arrest, see **Annex L**.

### **2.7.1.6 Limits of equipment use and compatibility**

**2.7.1.6.1** Equipment designed specifically for work restraint should not be used for work positioning or as fall arrest equipment. Equipment designed specifically for work positioning should not be used as fall arrest equipment. Some equipment is designed to allow the attachment or connection of other components in order to meet the requirements of a category of work other than the one for which it was primarily designed. An example is a sit harness (for work positioning) which is designed to accept the connection of a chest harness which will allow these two combined parts to meet the requirements of a full body harness (for fall arrest).

**2.7.1.6.2** Purchasers should ensure that components in any system are compatible and that the safe function of any one component does not interfere with the safe function of another.

**2.7.1.6.3** Equipment should only be used in accordance with the information supplied by the manufacturer.

**2.7.1.6.4** The equipment chosen should be able to withstand any loads or forces that might be imposed on it, plus an additional adequate safety margin, and the rope access system itself should be designed to minimize the potential loads placed upon it. The rope access system generally should be designed to avoid a fall.

**2.7.1.6.5** No item of rope access equipment should be capable of being accidentally removed, dislodged or become unfastened from the anchor lines during use.

**2.7.1.6.6** When choosing equipment for a particular application, account should be taken of weakening factors, such as the loss of strength at knots (see **2.11.5**).

**2.7.1.6.7** Rope access technicians should be aware that climatic conditions can affect the performance of some equipment or combinations of equipment. For example, humidity can alter (reduce) the friction provided between the descending device and the anchor line, and thus the performance is altered. This also applies to some ascending devices. Cold conditions can also affect performance, e.g. icy anchor lines can affect the grip of anchor line devices on them. Wet anchor lines can exhibit greater elongation characteristics than dry ones and wet polyamide anchor lines tend to be less resistant to abrasion. In very cold conditions, the strength of some metals is affected. Rope access technicians should check the information provided by the manufacturer to determine the acceptable operating conditions.

**2.7.1.6.8** Purchasers are recommended to check with equipment suppliers that equipment made from man-made fibres, e.g. polyamide; polyester; polyethylene; polypropylene; aramid, is protected against ultra-violet light (UV). Most standards do not have requirements for resistance to UV degradation, so it is up to the purchaser to find out. UV is emitted by sunlight, fluorescent light and all types of electric-arc welding. The normal way to provide protection is by the inclusion of UV inhibitors at the fibre production stage but there are other possibilities, such as the type and colour of any dye used or the use of a protective covering.

### **2.7.1.7 Knowledge of equipment**

The manufacturer of personal fall protection equipment is required to supply product information. This information should be read and understood by the user before using the equipment. This also applies to replacement equipment, because changes might have been made to the original specification or advice given. Knowledge of the strengths and weaknesses of equipment can help to avoid misuse. This knowledge can be enhanced by studying the information provided with the product, catalogues, other technical brochures and the manufacturer's website, which often provides more detail.

## **2.7.2. Ropes (e.g. for anchor lines)**

**2.7.2.1** In the present state of materials science, only ropes made from polyamide or polyester are suitable for anchor lines for rope access. Other man-made materials might be useful in special situations but care should be taken to verify their suitability for the intended use.

**2.7.2.2** Ropes made from high modulus polyethylene, high tenacity polypropylene and aramid may be considered for use in exceptional circumstances, and only if appropriate anchor line devices (e.g. descending devices) are available. Ropes made from these materials might be useful where there is severe chemical pollution. However, polyethylene and polypropylene have much lower melting temperatures than polyamide or polyester and are more easily affected by frictional heat, for example from descending devices. Dangerous softening of polypropylene occurs at temperatures as low as 80 °C. Aramid has a very high melting point but poor resistance to abrasion, ultraviolet light and repeated bending. Both polyester and aramid fibres have lower elongation characteristics than polyamide, aramid being the lowest.

**2.7.2.3** Some new ropes can shrink by around 10% when wet, which could be a problem if egress and access at the bottom of an anchor line is required. Rope lengths should be chosen with this in mind. It may be advisable to uncoil a new rope and immerse it in water for a few hours and then allow it to dry naturally in a warm room away from direct heat. The length of the rope should be checked periodically with shrinkage in mind.

**2.7.2.4** Wire rope might be a suitable material for use in particular situations, providing that other appropriate components needed for the system are available and that any other system requirements are met. Attention is drawn to wire rope made from stainless steel. Great care should be taken when selecting or specifying anchor lines made from stainless steel as some types of stainless steel can have unpredictable fatigue and corrosion characteristics.

**2.7.2.5** Textile ropes constructed with a load-bearing core and an outer protective sheath are recommended, e.g. kernmantel construction. Ropes should be resistant to wear from the anchor line devices and should resist the ingress of dirt and grit. It is likely that the majority of anchor line devices used in rope access are compatible only with rope of kernmantel construction. However, ropes with other types of construction may be used if it is thoroughly verified that these give a similar level of safety and there are compatible anchor line devices.

**2.7.2.6** Efficiency in descending, ascending and, to some extent, working in one place for any length of time, depends on the elongation characteristics of the working line. Therefore, in most cases, the working line (and normally also the safety line) should be a low-stretch kernmantel rope.

**2.7.2.7** Low-stretch kernmantel ropes are used almost universally for both the working line and the safety line. However, these ropes are not designed to sustain major dynamic loads, and should never be used in situations where a fall greater than fall factor one could be sustained. For more information on fall factors, fall distances and associated risks, see **Part 3, Annex Q**. On very long drops, the use of ropes of even lower elongation might be appropriate but, as these have minimal energy absorption, the user would need to incorporate an energy absorber in the back-up system.

**2.7.2.8** In situations where the possibility of a substantial dynamic load exists, a dynamic rope should be used. Within the International Mountaineering and Climbing Federation (UIAA) Standards and the European Standards (ENs), there are three categories of dynamic rope: single, half and twin. For rope access, the use of 'single' rope with a nominal diameter of 11 mm is recommended.

*NOTE* In choosing the type of rope to be used, it is important to balance the needs of energy absorption with the need to avoid excessive elongation or rebound, which could result in the rope access technician striking the ground or structure, or ending up fully immersed in water or other liquid.

**2.7.2.9** Important factors for the selection of ropes for use as anchor lines include:

- a) compatibility with chosen anchor line devices, e.g. descending devices; ascending devices; backup devices.
- b) resistance against chemicals; ultra-violet degradation; wear and abrasion;
- c) the ease with which knots can be tied, e.g. to form terminations;



- d) the static strength of the rope after terminations have been made is a minimum of 15 kN, e.g. when tested in accordance with EN 1891:1998 Type A;
- e) having a substantially higher melting point than could be generated during rope access, including rescue;
- f) performance in relevant environmental conditions, e.g. cold; hot; wet; dirty.

**2.7.2.10** Examples of appropriate standard for ropes are:

- a) for low-stretch kernmantel ropes: EN 1891; CI 1801;
- b) for dynamic kernmantel ropes: EN 892; UIAA-101;
- c) for all types of kernmantel rope: CI 2005.

*NOTE* CI 1801 provides requirements for low stretch and static kernmantel ropes. The elongation requirements for low stretch kernmantel rope in CI 1801 are not the same as those in EN 1891: low stretch kernmantel rope conforming to CI 1801 is likely to be more elastic. The elongation requirements for low stretch kernmantel rope in EN 1891 are closer to those for static kernmantel rope in CI 1801.

### **2.7.3 Harnesses**

*NOTE* Historically, rope access technicians used a sit harness coupled with a chest strap or chest harness, which served a dual purpose of holding the chest ascender in its correct orientation and in assisting the user to be supported in a more upright position than typically a sit harness would do alone. Although this combination is still common, an alternative is to use a specially designed full body harness that combines the necessary sit harness support function with the facilities described above and which also provides a high attachment point for the backup device (typically via a short device lanyard). In the unlikely event of a fall, the wearer is always maintained in an upright position and, arguably, the potential for hyperextension of the head (whiplash) is reduced. These harnesses usually conform to appropriate fall arrest harness standards and thus meet legislative and other authority requirements or recommendations for harnesses to be used for work where a fall could occur.

**2.7.3.1** Work positioning harnesses for rope access work may be a sit harness or full body harness, depending upon the nature of the work to be carried out and the regulations applicable where the work is being undertaken.

**2.7.3.2** Work positioning harnesses are generally designed to be strong enough to arrest a free fall of limited distance and force, but might not conform to the other essential requirements for a fall arrest system (e.g. for use in lead climbing), unless combined with appropriate additional components.

**2.7.3.3** For ergonomic reasons, it is recommended that a low front attachment point on the harness is used to connect descending devices, ascending devices (via appropriate device lanyards) and anchor lanyards. Back-up devices are generally best connected to the anchor line via a high front attachment point. This is to minimize any whiplash effect in a fall; to keep the body upright after a fall and to facilitate self-rescue.

**2.7.3.4** Harnesses used should be capable of supporting the wearer in a comfortable position, e.g. while working or awaiting rescue, while allowing unhindered operation of other devices in the system. Before using a harness for the first time, the user should carry out a suspension test in a safe place to ensure that the harness is comfortable and has sufficient adjustment. For details of an appropriate test, see **Part 3, Annex D**.

**2.7.3.5** Selection criteria for harnesses include:

- a) the ability to be adjusted to fit the rope access technician for size and comfort when wearing a maximum and a minimum of clothing;
- b) whether to use a sit harness or a full body harness (check industry and legislative requirements);

- c) suitability for the amount of support needed, dependent upon the person and the work to be done;
- d) suitability of the harness attachment points for ascending devices, descending devices, back-up devices, device lanyards and anchor lanyards;
- e) the ability to connect and work with a seat;
- f) resistance of creep (slow slippage) of straps through their adjusters;
- g) resistance to ultra-violet degradation;
- h) resistance to chemicals, wear and abrasion.

**2.7.3.6** Examples of appropriate standards for harnesses are:

- a) for sit harnesses: EN 813;
- b) for full body harnesses: EN 361; ISO 10333-1; ANSI/ASSE Z359.1 (maximum fall distance 0.6 m and maximum impact load 4 kN for sternal attachment).

## **2.7.4 Connectors**

**2.7.4.1** Connectors with a gate locking mechanism such as a screwed sleeve or an automatic locking mechanism are the only types that can provide the required level of security for use in rope access. Connectors made of steel should be used if connecting to steel cables, shackles or eyebolts. Connectors that are to be used to attach to an anchor should be of such a design and size that they are able to rotate in the anchor and sit correctly, without hindrance and without loosening the anchor.

**2.7.4.2** Screwlink connectors might be more appropriate than other types of connector for infrequently operated connections or where there might be a loading against the gate.

**2.7.4.3** The strength of a connector is determined by applying an outward force along its length (the major axis) using two round metal bars (see **Figure 2.1**). If the connector has an asymmetrical shape, the test load is normally applied along a line close to the spine. If the loading in use is not in such a position — for example, because of the use of wide tape slings or double ropes — the weaker, gated side of the connector will take more of the load and its failure load could be less than specified. Static strength tests resulted in strength losses of up to 45%. Therefore, care should be taken in use to see that asymmetrical connectors are loaded correctly, i.e. in a line close to the spine, or have a suitable factor of safety. See **Figure 2.1**.

**2.7.4.4** The weakest part of most connectors is the gate and loading against it should be avoided. Unintentional loading against the gate is usually caused by the movement of straps or other connecting components from their intended position while unloaded. Connectors with a captive eye, which holds the lanyard in place, can partially overcome this problem and are recommended, where appropriate. Alternatively, triangular or semi-circular shaped screwlink connectors or other specially designed connectors that have a high minor axis strength (i.e. across the gate) may be chosen.

**2.7.4.5** The minimum recommended static strengths for connectors are given in **Table 2.1**.

**2.7.4.6** When selecting a connector, users should take account of its gate locking system and how and where the connector is going to be used in the rope access system, to protect against *roll-out*. Roll-out is the result of pressure on the gate by another component connected to it, such as an anchor line device, a harness attachment point (especially if made from metal), a webbing lanyard, an anchor line or another connector. If the safety catch mechanism on the locking gate is actioned while this pressure is applied, it can cause the inadvertent opening of the connector gate and the roll-out (i.e. release) of the component from the connector.

**2.7.4.7** In roll-out, the safety catch is usually accidentally tripped in one of two ways, depending upon the type of locking gate. These are:

- a) by rope or webbing running over the top of some types of gate which incorporate a twist-action safety catch;
- b) unintentional pressure against the user's body or the structure on the safety catch of double-action safety hooks.

**Table 2.1 — Recommended minimum static strengths for connectors**

Type of connector	Major axis with gate closed and unlocked (kN)	Major axis with gate closed and locked (kN)	Minor axis with gate closed* (kN)
All connectors except those used where there is likely to be a loading across the minor axis, e.g. to connect twin harness attachment points, i.e. so-called multi-use connectors and screwlink connectors, which are often used for the same purpose.	15	20	7
Multi-use connectors	15	20	15
Screwlink connectors	Not applicable	25	10
* Certain types of connector are unable to be tested across the minor axis because of their special design.			

**2.7.4.8** The potential problems of loading against the gate and subsequent roll-out can generally be avoided by careful thought of how pressure could be applied unintentionally to the connector during use and then choosing the correct connector to take account of this.

**2.7.4.9** Other selection criteria for connectors include:

- a) resistance to corrosion, wear, abrasion and fracturing;
- b) robust enough to work in cold, dirty or gritty conditions;
- c) ability to be opened, closed and locked in difficult circumstances, e.g. with gloved hands;
- d) gate-open size and design to suit the work in hand, e.g. connection to scaffold tubes.

**2.7.4.10** Examples of appropriate standards for connectors are:

- a) for all types (including self-closing and self-locking types): EN 362;
- b) for self-closing and self-locking types only: ISO 10333-5; ANSI/ASSE Z359.12.

## **2.7.5 Descending devices**

*NOTE This code of practice does not cover powered descending devices (e.g. powered by battery or petrol), although the principles that apply to the safe use of manually-operated descending devices are likely to apply also to powered versions.*

**2.7.5.1** Descending devices are used to attach the rope access technician to the working line and to control the descent. If a connector is used to connect the descending device to the user, only an appropriate locking connector should be used. This may be a manual or automatic locking connector. Automatic locking connectors should have protection against roll-out (see **2.7.4.6**, **2.7.4.7** and **2.7.4.8**).

**2.7.5.2** When selecting a descending device, it is essential that the probability of foreseeable misuse and the consequences of such misuse are assessed. When such an assessment has been made, a residual risk of misuse may exist, which should be addressed by identifying and applying

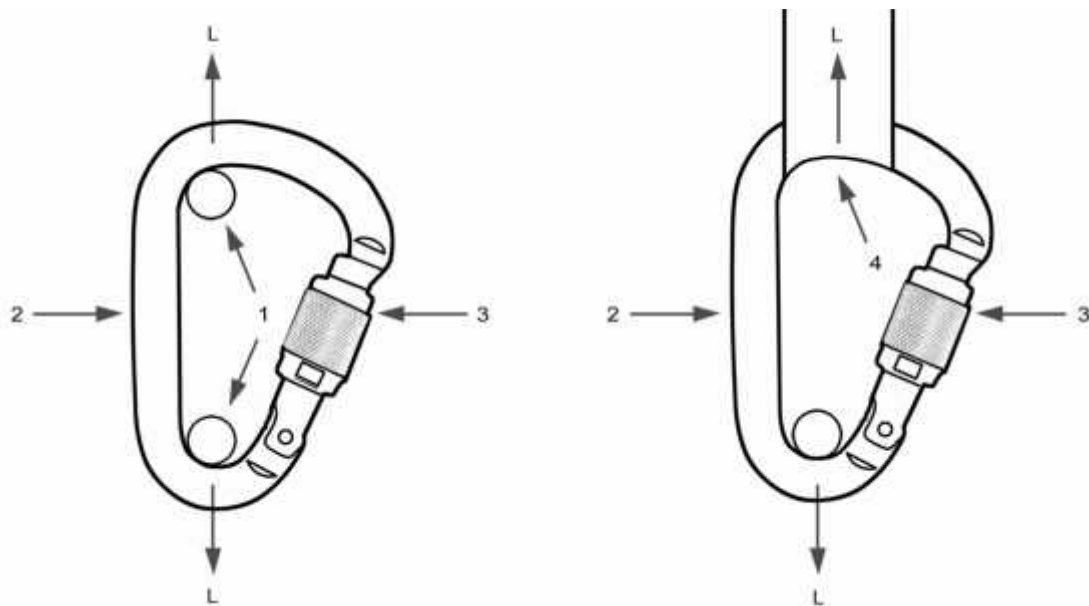

a) Loading during the static strength test

b) Possible loading (closer to weaker, gated side) during use with a wide webbing lanyard

**Key**

- 1 Bars 12 mm diameter
- 2 Connector spine
- 3 Gate

- 4 Webbing lanyard
- L Direction of load

**Figure 2.1 — Example of the loading positions of a connector in a static strength test and the difference in use, e.g. when loaded with a wide webbing lanyard**

specific control measures, such as the selection of alternative equipment, extra training, modification of work practices, increased supervision or a combination of these.

**2.7.5.3** Special consideration should be given to the suitability and performance of descending devices during rescue, when potential loads could be significantly higher than the manufacturer's maximum rated load.

**2.7.5.4** Descending devices should:

- a) be selected such that the anticipated loading is appropriate for the mass of the rope access technician, including any equipment worn, i.e. in accordance with the manufacturer's maximum and minimum rated loads;

- b) be appropriate for the length of the descent;
- c) be capable of two-person loading and provide appropriate control over the speed of descent if workmate retrieval is going to be carried out using this device;
- d) be suited to the prevailing environmental conditions, e.g. wet; icy; muddy; abrasive; corrosive;
- e) be capable of giving the rope access technician appropriate control over the speed of descent and should not cause undue shock loads to the working line when braking;
- f) automatically stop the descent if the rope access technician loses control, i.e. lock automatically in the hands-free mode (noting that it is common and acceptable for some minor creep of the descending device along the anchor line to occur);
- g) preferably fail to safe in all modes of operation, e.g. stop the descent automatically when gripped too tightly in panic (panic locking);
- h) be simple to attach to the working line and have protection against incorrect attachment (e.g. via design; marking; warnings);
- i) minimize damage, wear or twist to the working line;
- j) have good heat dissipation characteristics (important on long descents or descents in high ambient temperatures);
- k) be compatible with the anchor line type and diameter;
- l) not be capable of inadvertent detachment from the working line or becoming detached under any circumstances while carrying a rope access technician's weight or while supporting the weight of two persons during a rescue.

**2.7.5.5** Examples of appropriate standards for descending devices are:

- a) EN 12841, Type C; ISO 22159.
- b) For rescue only: EN 341.

## **2.7.6 Ascending devices**

*NOTE This code of practice does not cover powered ascending devices (e.g. powered by battery or petrol), although the principles that apply to the safe use of manually-operated ascending devices are likely to apply also to powered versions.*

**2.7.6.1** Ascending devices are attached to the working line and are used when the rope access technician wishes to climb up it. Typically, there are two types of ascending device used in a rope access system. The first type is used to connect the rope access technician directly to the working line via the harness; the other type is attached to a foot loop to aid climbing and is also connected back to the harness with a device lanyard to provide additional security.

**2.7.6.2** Ascending devices should be of a type that cannot be detached accidentally from the working line and should be chosen so that the risk of damage to the working line is minimized when in use. Any dynamic loading should be avoided, as damage could result to either the ascending device or the working line.

**2.7.6.3** Ascending devices should be chosen bearing in mind suitability for use in the prevailing environmental conditions, e.g. wet; muddy; icy; abrasive; corrosive.

**2.7.6.4** Other selection criteria include:

- a) simplicity of connection to the working line;
- b) ease of adjustment when moving it up and down the working line;
- c) effective grip on the working line;
- d) resistance to abrasion, e.g. caused by dirty working lines;
- e) minimal potential for damage to working lines under foreseeable loads, e.g. the sharpness of teeth on the cam that grips the working line;
- f) suitability for specific use, e.g. mounting on the chest when ascending;
- g) ability to connect device lanyards and other devices.

**2.7.6.5** An example of an appropriate standard for ascending devices is EN 12841, Type B.

### **2.7.7 Back-up devices**

**2.7.7.1** Back-up devices are used to attach the rope access technician to the safety line. This is normally done by linking the back-up device to the user's harness with a device lanyard. In the event of a failure of the working line or loss of control by the rope access technician, back-up devices are intended to lock on to the safety line without causing catastrophic damage to the safety line and also to absorb the limited shock load that might occur.

**2.7.7.2** When back-up devices are dynamically tested in accordance with standards, the tests only represent a (vertical) free-fall. In certain circumstances, an uncontrolled descent may not be a free fall and the back-up device may not activate, e.g. if the user loses control of the descending device during descent, if a fall is impeded by the structure or while descending at an angle other than vertical. Back-up devices should be selected which are known to perform in such a way that an uncontrolled descent at all angles likely to be encountered during use would be prevented or minimized.

**2.7.7.3** When used in accordance with the manufacturer's instructions, the combination of back-up device, device lanyard, connectors and harness should be able to limit the force on the user to a maximum of 6.0 kN in the event of a working line failure.

*NOTE 6 kN is a recognized threshold of injury.*

**2.7.7.4** It is recommended that back-up devices used are of a type that will not slip at a static load of less than 2.5 kN to allow for two persons to be supported from it, which may be necessary in a rescue situation.

**2.7.7.5** When selecting a back-up device, it is essential that the probability of foreseeable misuse and the consequences of such misuse are assessed. When such an assessment has been made, a residual risk of misuse may exist, which should be addressed by identifying and applying specific control measures, such as the selection of alternative equipment, extra training, modification of work practices, increased supervision or a combination of these.

**2.7.7.6** Special consideration should be given to the suitability and performance of back-up devices if they might be used during rescue, because potential loads could be significantly higher than the manufacturer's maximum rated load.

**2.7.7.7** Additional selection criteria for a back-up device include:

- a) that the anticipated loading is appropriate for the mass of the rope access technician including any equipment worn, i.e. in accordance with the manufacturer's maximum rated load;

- b) the suitability with regard to arresting the mass of the user, including any equipment worn or carried;
- c) the ability to keep any fall as short as possible;
- d) that it does not cause catastrophic damage to the safety line when arresting a fall;
- e) the suitability with regard to arresting a two-person load if workmate retrieval is going to be carried out;
- f) that it cannot be inadvertently disconnected from the safety line;
- g) compatibility with the safety line type and diameter;
- h) the ability to position the device anywhere on the safety line;
- i) the suitability for the prevailing environmental conditions, e.g. wet; icy; dirty; abrasive; corrosive;
- j) minimal manipulation required by the rope access technician;
- k) preferably fail to safe in all modes of operation, e.g. prevent or arrest a fall even when gripped in panic.

**2.7.7.8** An example of an appropriate standard for back-up devices is EN 12841, Type A.

## **2.7.8 Lanyards and slings**

### **2.7.8.1 General**

**2.7.8.1.1** Lanyards and slings are made in various forms and may be used for one or more applications. See **Figure 2.2** for examples.

**2.7.8.1.2** Some lanyards are used to provide a link between the user's harness and certain anchor line devices, namely the foot ascender and the back-up device. In this code of practice, they are referred to as *device lanyards*. Such lanyards are generally made from dynamic mountaineering rope and are fitted with knotted terminations but are sometimes other types of energy absorber or energy-absorbing lanyard.

**2.7.8.1.3** Other lanyards, also generally made from dynamic mountaineering rope and fitted with knotted terminations, are used to connect the rope access technician directly to an anchor point via a connector. In this code of practice, they are known as *anchor lanyards*.

*NOTE* The lanyards described in **2.7.8.1.2** and **2.7.8.1.3**, both of which are often commonly called *cow's tails*, have been separated into the two types (and renamed) because their specific use and requirements are or can be different.

**2.7.8.1.4** Slings are used to provide a link between structural anchors, e.g. a steel beam, or anchor devices, e.g. an eye bolt, to the attachment point for anchor lines (via a connector or connectors), and are normally made from textile webbing, textile rope or wire rope and, sometimes, chain. These are known as anchor slings.

**2.7.8.1.5** Lanyards and slings can be a fixed length or the length can be adjustable.

**2.7.8.1.6** Webbing and rope made from man-made fibres used in the manufacture of lanyards and slings should be chosen so that any mechanical damage (e.g. abrasion) will become readily visible well before any loss of strength becomes significant. Stitching should be in a contrasting shade or colour to that of the webbing to facilitate its inspection. The webbing, rope and stitching should be protected against ultra-violet degradation, e.g. by the use of ultra-violet inhibitors and/or by a protective covering.

**2.7.8.1.7** The construction of webbing should be such that it does not unravel if one of the edges is cut. This applies to all components made from webbing.

**2.7.8.1.8** Wire rope used in the manufacture of lanyards and slings should have a minimum static strength of 15 kN.

### **2.7.8.2 Device lanyards and anchor lanyards**

**2.7.8.2.1** Device lanyards and anchor lanyards should be able to withstand any dynamic forces that might be imposed upon them in times of emergency. Device lanyards and anchor lanyards made of rope should have a performance at least equal to that of a “single” dynamic mountaineering rope, e.g. one conforming to European Standard EN 892 or the equivalent standard by the International Mountaineering and Climbing Federation (UIAA). Both these standards require the rope to have energy absorbing properties. Knots to be used for the terminations should be chosen for their energy absorbing characteristics as well as their strength and should be tied only by competent persons. The energy absorption provided by the materials used in the construction of the lanyard is enhanced by the knots used to terminate them and knotted terminations are therefore recommended. An example of a knot that is particularly good at absorbing energy is the scaffold knot (often referred to as a barrel knot), see **Figure 2.3**, which is frequently used in the end of the anchor lanyard. The knot in **Figure 2.3** shows the knot tied with two turns of the rope. There is a version that uses three turns. Both versions are acceptable. It is good practice to re-tie, dress and set (i.e. hand tighten) knots periodically as part of the inspection process.

**2.7.8.2.2** Device lanyards and anchor lanyards made from dynamic rope with knotted terminations should have a minimum static strength of 15 kN. The strength of the combination of chosen rope and knots should be confirmed, e.g. by testing the lanyard or by reference to information supplied by the manufacturer.

**2.7.8.2.3** Other types of lanyard may be appropriate for use in rope access, e.g. lanyards conforming to standards where the minimum static strength requirement is typically 22 kN and energy absorption is not considered. For proprietary lanyards, the information supplied by the manufacturer should be consulted.

**2.7.8.2.4** If an energy absorber is incorporated into the system (other than that provided by the energy absorbing qualities of the material and termination knots used in the construction of the device lanyard or anchor lanyard), it should conform to an appropriate standard for energy absorbers.

**2.7.8.2.5** To minimize any fall potential and to aid manoeuvres in a rescue situation, it is important that the length of device lanyards is kept as short as possible and limited to the rope access technician’s reach. This will vary from person to person.

**2.7.8.2.6** Anchor lanyards are normally used in two lengths; the shortest typically when changing from one anchor line to another during descent, e.g. at a re-anchor, and the longest typically when changing from one anchor line to another during ascent, e.g. at a re-anchor. The lengths of the anchor lanyards should be as short as possible, i.e. no longer than is necessary to enable the rope access technician to carry out the required manoeuvres. This is not only for maximum efficiency in carrying out the manoeuvres but also to minimize the potential for high impact forces in any fall that might occur.

### **2.7.8.3 Anchor slings**

**2.7.8.3.1** Anchor slings may be used where there are no suitable anchors to which the anchor lines can be attached directly. If made from man-made fibres, anchor slings should have sewn joints and have a minimum static strength of 22 kN. Anchor slings made from wire rope should have a minimum static strength of 15 kN.

**2.7.8.3.2** Where the included angle at the anchor point (the Y angle) is high and produces a multiplier effect (i.e. it increases the loading on the anchor sling), the extra forces that are produced



need to be taken into account. An example is when an anchor sling is wrapped around a lift-shaft housing. See **Figure 2.4**.

#### **2.7.8.4 Selection criteria for device lanyards, anchor lanyards and anchor slings**

Selection criteria for device lanyards, anchor lanyards and anchor slings include:

- a) adequate strength;
- b) energy absorbing characteristics, particularly for device lanyards and anchor lanyards;
- c) compatible with the connectors being used, e.g. fits through the connector gate and does not bunch and distort unduly under load;
- d) suitable length (adjustable or fixed);
- e) suitable for attachment to the harness, where appropriate;
- f) protected at wear points;
- g) manufactured from appropriate materials for the task in hand, e.g. in some cases, steel cable might be more suitable than rope or webbing, and for the work environment;

#### **2.7.8.5 Other information on lanyards**

**2.7.8.5.1** Information on other types of lanyards is given in **Part 3, Annex E**.

**2.7.8.5.2** Examples of appropriate standards for lanyards are:

- a) EN 354; ISO 10333-2; ANSI/ASSE Z359.1;
- b) For the construction of device lanyards and anchor lanyards: EN 892; UIAA-101.

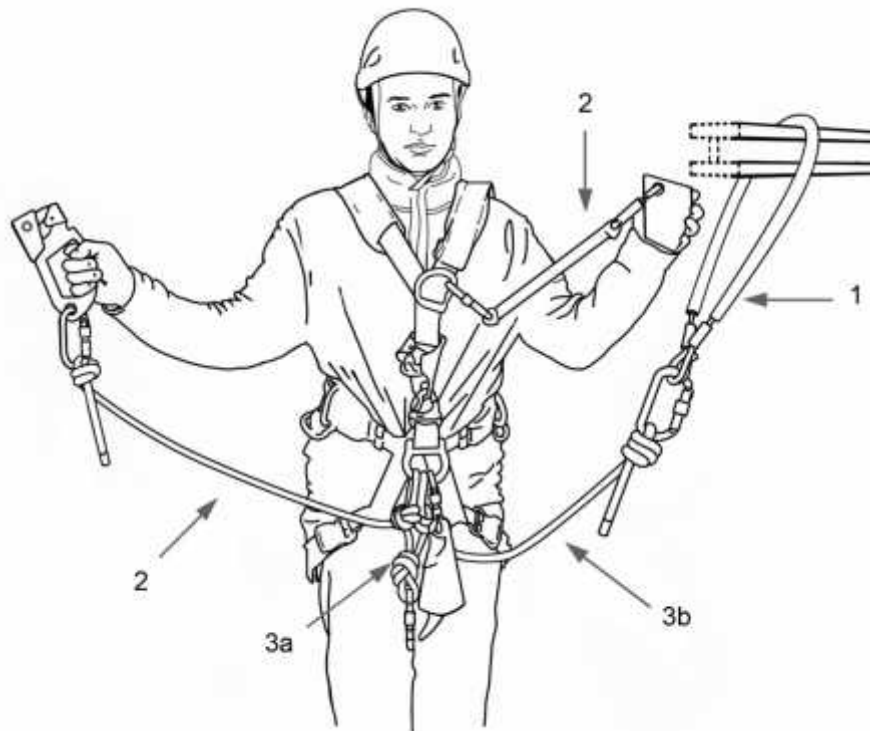

**Key**

- 1 Anchor sling (may be a round sling or a strop)
- 2 Device lanyard
- 3a Short anchor lanyard
- 3b Long anchor lanyard

**Figure 2.2 — Illustration to show an example of an anchor sling and examples of different types of lanyard**

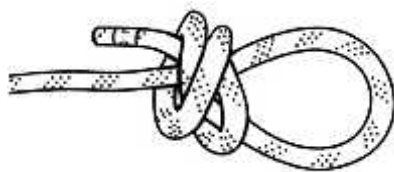

a) Scaffold knot with double twist: loose



c) Scaffold knot with triple twist: loose



b) Scaffold knot with double twist: set

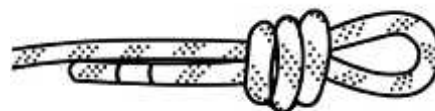

d) Scaffold knot with triple twist: set

**Figure 2.3 — Example of a scaffold knot (often referred to as a barrel knot)**

## 2.7.9 Anchors

*NOTE* The word *anchor* in this code of practice is used as a general term to describe, as a noun, a fitted or unfitted anchor device, or a structural anchor containing an anchor point and, as a verb, the act of connecting to a fitted anchor device or structural anchor. Various terms relating to anchors are explained in Part 1 by way of definitions and the accompanying Figure 1.1 in that part.

**2.7.9.1** Anchors are used via their *anchor point(s)* for the attachment of anchor lines (i.e. the working line and the safety line) to the structure or natural feature and also for other purposes, e.g. to reposition the anchor lines to avoid abrasion; to alter the direction of the anchor lines (deviation anchors); to maintain the anchor lines in their intended position; for the attachment of persons, either directly or indirectly. Anchors are fitted to *anchorage*s at an *anchorage point*, i.e. the particular place on the anchorage used for the attachment of the anchor device.

**2.7.9.2** There are many different types of anchors. Examples are: eye bolts; anchor slings; specially designed rail anchor systems (which typically are permanently fitted around the perimeter of the roof of a building so that attachment can be made anywhere along them); ground anchor stakes (fixed into the ground); deadweight anchors; counterweight anchors; beam clamps. Examples of anchorages are: structures made from steel beams; lift-shaft housings on tower blocks; sound concrete and natural geological features such as a rock face or a tree. Anchors and anchorages should be unquestionably reliable.

**2.7.9.3** It is essential that great care is taken when selecting anchor devices that they are appropriate to the situation in which they are fitted or to be fitted and used, e.g. that they are the correct type of anchor device for the given situation and that they are positioned and fitted correctly. It is also essential that anchor devices are fitted, tested, inspected and used by competent persons and strictly in accordance with manufacturer's instructions.

**2.7.9.4** The selection of anchors largely depends on whether anchors such as appropriate eyebolts could be fitted or are already in place and in the correct place, and whether opportunities exist to use other types of anchor, e.g. anchor slings fitted around the structure.

**2.7.9.5** Anchors should be of an adequate strength, bearing in mind the mass of the user including any equipment worn or carried. See **2.11.2.6** to **2.11.2.8** for more advice.

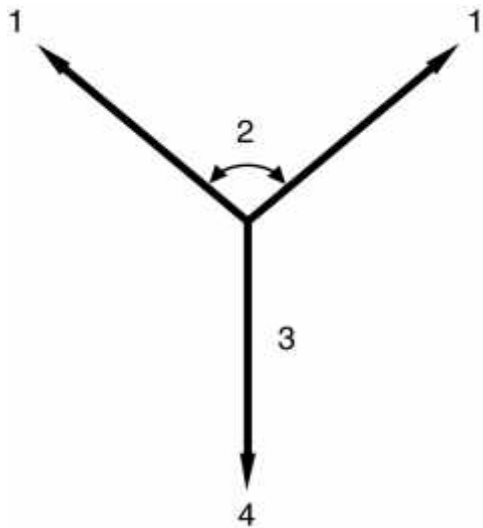

a) General arrangement

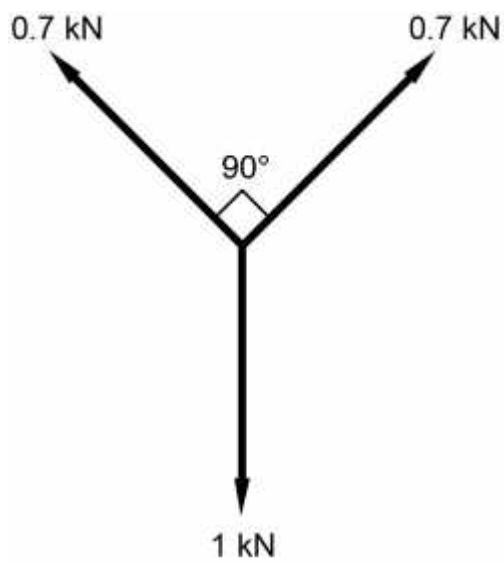

b) Preferred maximum angle

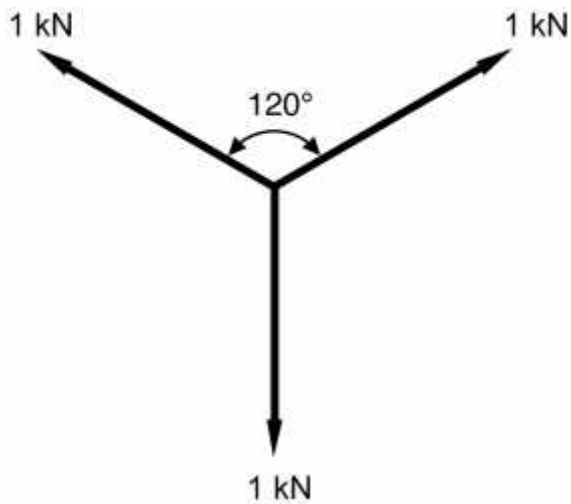

c) Loading at 120°

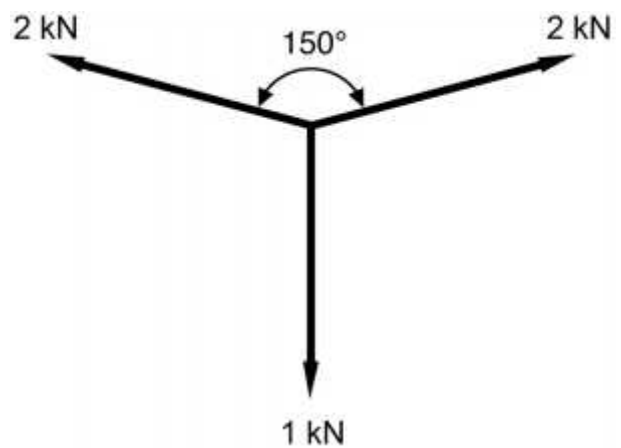

d) Loading at 150°

**Key**

- 1 Anchor
- 2 Y angle
- 3 Anchor line
- 4 Load

**Figure 2.4 — Examples of the increase in loading on anchors, anchor lines and anchor slings caused by an increase in the Y angle**

**2.7.9.6** When selecting, fitting and using anchors, the principle of double protection (see **2.11.1**) applies and, therefore, at least two anchors should always be used.

**2.7.9.7** Rope access technicians and rescue services should be aware that additional anchors may be required to facilitate workmate retrieval. These should be of adequate strength for at least a two-person load.

**2.7.9.8** The subject of selection, fitting and use of anchors is complex. See **2.11.2** and **Part 3, Annex F** for further information.

**2.7.9.9** Examples of appropriate standards for anchor devices are: BS 7883 and EN 795.

## **2.7.10 Protectors for anchor lines**

*NOTE This guidance on the protection of anchor lines against hazardous surfaces may also be applied in context to the protection of lanyards and slings.*

**2.7.10.1** Wherever possible, anchor lines should be rigged so that they hang free and do not come into contact with hazardous surfaces, e.g. edges or abrasive or hot surfaces, at any time during the rope access activity. Where this cannot be done, e.g. where it is not possible to arrange a natural free hang or use deviations or re-anchors, it is essential that anchor lines are suitably protected against the hazard. This can be achieved in various ways, e.g. by the use of *edge protectors* such as rollers; metal edge plates; edge padding, or by *anchor line protectors* such as a textile sheath which encapsulates the anchor line, or by a combination of both types of protector. See **2.11.3** and **Annex P** for more information on the protection of anchor lines.

**2.7.10.2** Selection criteria for edge protectors and anchor line protectors include:

- a) suitability for the particular site conditions, e.g. provides adequate protection against cutting, abrasion, excessive heat or chemical contamination;
- b) suitability for compatibility with anchor line type, e.g. construction; diameter; number of anchor lines;
- c) a features to allow them to be tied off (if required) to keep the edge protectors and anchor line protectors in their intended place and to maintain the anchor line(s) in position within or on them;
- d) a design that allows the rope access technician to place and to pass the edge protector or anchor line protector;
- e) the ability to inspect the anchor line(s) while located in or on the edge protector or anchor line protector.

*NOTE There are no known standards for edge protectors and anchor line protectors.*

## **2.7.11 Work seats**

**2.7.11.1** When there is a need for rope access technicians to remain suspended in one place for more than a few minutes, support additional to that provided by the harness is recommended. The use of even a simple work seat can enhance the comfort, health and safety of a rope access technician, possibly including a reduction in the risk of experiencing the symptoms of suspension intolerance. For more information on suspension intolerance, see **Part 3, Annex G**.

**2.7.11.2** The work seat should be fitted in such a way that the harness remains the primary means of attachment to the anchor lines, should the work seat fail.

*NOTE There are no known appropriate standards for work seats.*

## 2.7.12 Helmets

**2.7.12.1** Rope access technicians should wear protective helmets that are suitable for the type of work being undertaken. Helmets that conform to standards for either mountaineering or industrial use might be suitable. Some industrial helmets might not be suitable because they might not have sufficient side impact protection or strong enough chinstraps.

**2.7.12.2** Chinstraps on helmets used in rope access work should prevent the helmet from coming off the head. This is typically achieved by the incorporation of “Y” shaped straps in the design of the helmet. Helmets should always be used with the chinstrap fastened.

**2.7.12.3** Selection criteria for helmets include:

- a) light weight, but without compromising safety;
- b) good fit, i.e. adjustable to the wearer’s head size;
- c) the ability to mount ancillary equipment such as communications equipment; headlamp; ear protectors; visors;
- d) unrestricted vision (downwards, sideways and upwards);
- e) good ventilation, particularly in hot climates.

**2.7.12.4** Examples of appropriate standards for helmets (when the caveats in the notes are taken into account) are:

- a) Industrial: EN 397; EN 14052;
- b) Mountaineering: EN 12492.

*NOTE 1 Users should check carefully the performance of industrial helmets conforming to European Standard EN 397 as they might not have the all the performance requirements for the safety of rope access technicians, e.g. front, side and rear energy absorption capacity (not specified in EN 397); appropriate chinstrap and fastening arrangement; low temperature use and ventilation (optional in EN 397).*

*NOTE 2 Helmets utilizing expanded polystyrene shells (common in helmets conforming to European Standard EN 12492) are unlikely to withstand the rigours of industrial use and, therefore, are generally not recommended.*

## 2.7.13 Pulleys

**2.7.13.1** Pulleys are used in a variety of rope access manoeuvres. They should be appropriate for their intended use, i.e. by personnel, and be suitably load-rated. Rope access technicians should be aware of the possible increase of loadings on anchors in some rigging situations.

**2.7.13.2** Examples of appropriate standards for pulleys are: EN 12278; UIAA 127.

## 2.7.14 Clothing and protective equipment

**2.7.14.1** Rope access technicians need to be appropriately dressed and equipped for the work situation and conditions.

**2.7.14.2** It can be difficult for rope access technicians to avoid exposure to changing climatic conditions or harmful substances when working at a height. Employers should assess carefully what the most appropriate clothing would be to guard against such hazards. This protective clothing should be provided and measures taken to ensure that it is worn.

**2.7.14.3** Rope access technicians should wear the following:

- a) protective clothing (e.g. overalls) that have no loose parts, which might become caught in any moving equipment. Pockets should be fitted with zip or touch-and-close type fastenings rather than buttons. Waterproof and/or windproof clothing should be provided where necessary. Flame proof or flame resistant overalls should be provided for welding, burning or cutting work;
- b) suitable footwear, which fits well, provides a good grip and gives an adequate level of protection for the task being undertaken. Special protective boots may be needed when grit blasting or ultra-high pressure water-jetting to prevent injury.

**2.7.14.4** If equipment is to be fitted to the user, it is important that it is comfortable to wear and fits the wearer properly when correctly adjusted. This should be checked in a safe place, before work commences. Such equipment should not significantly hinder the wearer from carrying out their duties or from properly operating the anchor line devices.

**2.7.14.5** The following protective items might also be required:

- a) gloves, to protect against cold weather, injury or other harmful effects;
- b) eye protection, where debris is being cleared or material is being removed, or where drilling, blasting or percussion operations are being undertaken. Eye protection is usually also required if chemicals are being sprayed or painted, which could cause irritation or injury to the eyes. IRATA International work and safety statistics have shown numerous lost time incidents due to eye injury, including where visors or safety glasses have been worn. It is likely that the wearing of goggles would have prevented these injuries;
- c) respiratory protective equipment, where there is a risk of inhalation of harmful chemicals or dust. Many building chemicals are liable to be harmful, particularly in a situation where a rope access technician is unable to get quickly to a source of fresh water to dilute or wash the chemical away;
- d) hearing protectors, when noise levels could cause a risk of hearing loss to rope access technicians;
- e) buoyancy or life jackets, when working over water. These should be of a type capable of being secured to the wearer so that they cannot accidentally come loose in the event of a fall. In addition, they should not obstruct the wearer or prevent the efficient operation of the anchor line devices;
- f) protection against sunburn, e.g. by the use of a sunscreen.

**2.7.14.6** Any variation in normal procedures in the use of protective equipment on the worksite (e.g. lifejackets; eye protection; safety footwear; helmet), for whatever reason, should first be cleared with the site management.

## **2.8 Marking and traceability**

### **2.8.1 Load-bearing rope access equipment should carry sufficient marking:**

- a) to enable identification of the manufacturer and, where appropriate, the model/type/class of equipment;
- b) so that it can be easily associated with its respective documentation, e.g. certificates of conformity, examination and inspection records;
- c) to allow further traceability, e.g. to enable the isolation of a rogue batch of components;
- d) to meet any requirements of legislation, e.g. national regulations.

This is achieved typically by the use of an identifier, e.g. a manufacturer's serial number, or by batch marking with additional forms of identification, e.g. a coding system.

**2.8.2** Equipment that does not have adequate marking made by the manufacturer should be indelibly marked in a manner that does not affect its integrity, e.g. by the use of: plastic or metal tags, which can be stamped with data and fixed with cable ties; a suitable paint; a suitable adhesive tape. (The paint or adhesive should be of a type that is not capable of damaging the component being marked and should be applied and positioned so that it cannot obscure any defect.)

**2.8.3** Equipment such as ropes and harnesses could be indelibly marked by various methods, e.g. by marking their identification on a tape, which is then fixed in place by a heat-shrunk clear plastic cover. Lengths cut off a main rope could have the identity transferred to them sequentially; e.g. a piece of rope cut off a main rope numbered A1 could be numbered A1/1, A1/2 etc. Connectors are often colour coded to indicate an in-date inspection period, as older items often lack unique identification and marking by the user can be difficult.

**2.8.4** Metal items should not be marked by stamping, unless by agreement with the manufacturer. This is because stamping can cause the potential for cracking of certain metals under certain conditions and, therefore, great care should be taken if this method of marking is chosen. The marking of metal items by engraving should only be carried out in such a way that it does not affect the integrity of the equipment, e.g. by marking in a non-safety-critical area of a component. It should be noted that stamping and engraving may damage any applied corrosion-resistant surface, e.g. electroplating, and it is recommended that steps be taken to avoid this potential for damage, e.g. by coating the indentations made by the stamping or engraving with paint.

**2.8.5** Helmets should not be marked with adhesive labels or adhesive tape without permission from the manufacturer, as some solvents used in adhesives can adversely affect the helmet's performance. Care should be taken that equipment made from webbing or rope is not marked with damaging chemicals, e.g. inks, or products containing potentially harmful adhesives.

**2.8.6** The identification and traceability details should be matched to records of use to help in the equipment's care and maintenance. This also applies to hired or sub-contractors' equipment.



This page is intentionally blank

## 2.9 Records

**2.9.1** Records should be kept to track the use of individual pieces of equipment, its inspection and its maintenance. These should include at least the following:

- a) the name of the manufacturer;
- b) the name of the model, type or class of the equipment, as appropriate;
- c) the purchase date;
- d) the date of entry into service;
- e) the obsolescence date;
- f) the manufacturer's serial number or batch marking to enable traceability, e.g. to the production stage;
- g) the information supplied by the manufacturer, including instructions for use;
- h) the safe working load, working load limit or maximum and minimum rated loads, whichever is provided;
- i) any certificate of conformity, e.g. to a standard;
- j) the duration of active use, e.g. number of days;
- k) current location and where it is stored normally;
- l) any arduous conditions in which the equipment has been used, e.g. exposure to chemicals; abrasion; heavy grit; any unusual loads or damage imposed;
- m) any workmate retrieval carried out;
- n) the date and result of inspections, the type of inspection carried out (detailed or interim) and the date the next inspection is due;
- o) details of servicing, repairs or modifications.

Such information could help to determine when to take an item out of service.

**2.9.2** Records of inspections should be kept at least until a subsequent inspection is carried out and copies of inspection records should be made available for viewing by relevant persons (see **Part 3, Annex N**). Local legislation may determine the specific retention period for records.

This page is intentionally blank

## 2.10 Inspection, care and maintenance of equipment

### 2.10.1 General procedures

**2.10.1.1** The manufacturer should always provide information on the inspection, care and maintenance of equipment and this should be strictly followed. This section details good practice for rope access purposes.

**2.10.1.2** Procedures should be established by employers for the inspection and maintenance of equipment and the method by which this is to be recorded. The inspection and maintenance of equipment should only be carried out by competent persons. Inspection and maintenance may be carried out by the manufacturer's representative or specialist third parties if required.

**2.10.1.3** There are three types of inspection to which all rope access equipment should be subjected, to decide if the equipment can continue to be used or if it should be removed from use and destroyed. These are the pre-use check, the detailed inspection and, in certain circumstances, the interim inspection. Any item showing any defect during these inspections should be withdrawn from service, immediately if possible.

**2.10.1.4** It is essential that all load-bearing equipment is given a visual and tactile inspection by the user before each use to ensure that it is in a safe condition and operates correctly. In addition, there should be a formal process for detailed inspection of equipment by a competent person or persons. For an inspection checklist, see **Part 3, Annex H**.

#### 2.10.1.4.1 Pre-use check

The pre-use check consists of a visual and tactile inspection, which should be carried out before first use each day. Formal documentation for daily inspections should not be necessary, although some users may wish to include a checklist in daily inspection documentation. It is advisable to continue to monitor the condition of equipment throughout the duration of the task and not just at the start of the day.

#### 2.10.1.4.2 Detailed inspection

There should be a formal inspection procedure to ensure that equipment is thoroughly inspected by a competent person before equipment is used for the first time and then at intervals not exceeding six months, or in accordance with a written inspection scheme. This should be carried out in accordance with any manufacturer's guidance. The results of detailed inspections should be recorded. For a recommended list of information to be recorded following a detailed inspection, see **Part 3, Annex I**.

#### 2.10.1.4.3 Interim inspection

Where equipment is used in arduous conditions or exceptional events liable to jeopardize safety have occurred, further inspections (called *interim inspections*) should be carried out. These are inspections in addition to the detailed inspection and the normal pre-use check. They should be carried out by a competent person at intervals determined by the risk assessment. Suitable times for interim inspections can be decided by taking into account factors such as whether items are subject to high levels of wear and tear (e.g. unusual loadings or a gritty environment) or contamination (e.g. in a chemical atmosphere). Interim inspections should be recorded.

**2.10.1.5** It is essential that the person carrying out a detailed or interim inspection has the authority to discard equipment and is sufficiently competent, independent and impartial to allow objective decisions to be made. A competent person may exist within a rope access company, or could be a specialist supplier, manufacturer or a specialist repair organization. Companies should detail their arrangements for nominating the competent person or persons in their management system.

**2.10.1.6** Should there ever be any doubt about the continued serviceability of an item of equipment, the matter should be referred to a competent person or the equipment should be quarantined or discarded. It is good practice to try to establish how the damage occurred so that it can be prevented from happening again.

**2.10.1.7** Equipment subjected to a high impact force, e.g. in a fall or by a load being dropped on to it, should be withdrawn immediately from use.

**2.10.1.8** It is recommended that rope access equipment, indeed any personal fall protection equipment, is not subjected to proof load testing by the user.

## **2.10.2 Equipment manufactured from man-made fibres**

**2.10.2.1** All equipment manufactured from man-made fibres, e.g. ropes; webbing; harnesses; lanyards, should be chosen, used and inspected with particular care as it is susceptible to varying types and amount of damage, some of it not very easy to identify.

**2.10.2.2** Man-made fibres used in equipment for rope access are usually polyamide or polyester. Materials other than polyamide or polyester might be more suitable for certain working conditions but all have their limitations. Examples are:

- a) high performance polyethylene or high tenacity polypropylene, which might be more suitable where there is severe chemical pollution. However, polyethylene and polypropylene have much lower melting temperatures than polyamide or polyester and are more easily affected by frictional heat (dangerous softening of polypropylene occurs at temperatures as low as 80 °C);
- b) aramid, which is resistant to high temperatures, might be more suitable where equipment with a high melting point is required. However, aramid has low resistance to abrasion, repeated bending and to ultraviolet light.

Users should, therefore, take account of these properties, including the melting point, resistance to abrasion and flexing, resistance to ultraviolet light and chemicals, and the elongation characteristics, when selecting, using and inspecting such equipment.

**2.10.2.3** Ultraviolet light (UV) degrades and thus weakens most, if not all, man-made fibres. UV is emitted by sunlight, fluorescent light, which also contains ultraviolet light, and all types of electric-arc welding. The normal way to provide protection is by the inclusion of UV inhibitors at the fibre production stage but there are other possibilities, such as the type and colour of any dye used or the use of a protective covering. It is recommended that confirmation is obtained from the manufacturer that all man-made fibres in their equipment, including sewing threads, contain sufficient ultraviolet inhibitor for the conditions in which the equipment is to be used (ultraviolet light levels vary in intensity dependent upon location) and that the fibres have not been subjected to any dyeing or finishing process that could have detrimentally affected the level of protection. As ultraviolet inhibitors do not offer total protection, even man-made fibres that include them should not be exposed unnecessarily to sunlight, fluorescent light, and the light emitted by all types of electric-arc welding. It should be noted that many equipment standards for personal fall protection equipment do not address explicitly the potential for degradation by UV (or abrasion) during use of the product, relying instead on its strength including a safety factor when new. There is no guarantee that this approach will give sufficient protection against UV (or abrasion).

**2.10.2.4** Man-made fibres react in different ways when exposed to different chemicals at different concentrations and temperatures. For example, polyamide has good resistance to some alkalis, but the resistance is not total, does not apply to all alkalis and not at all concentrations or at all temperatures. Similar limitations apply to polyester, which has good resistance to some acids. Users should be aware of the chemicals present in the work environment and the potential effect on their equipment when selecting, using and inspecting it. For the properties of some man-made fibres used in the manufacture of rope access equipment, see **Part 3, Annex J**.

**2.10.2.5** The performance of some materials changes when they become wet. An example is polyamide fibre, which, when wet, loses between 10 % and 20 % of its strength. Fortunately, the loss is temporary and the strength is recovered when the material dries. In drop tests on dynamic rope that had been soaked in water for different periods, the impact loads increased by up to 22 % above those for dry ropes (typically by between 8 % and 12 %). Although the use of equipment made of webbing or rope in wet conditions does not usually need to be a cause for concern, it would be sensible to take extra care, particularly if the equipment is being used in conditions where it is subjected to loads close to its maximum rated load.

**2.10.2.6** Components made from man-made fibres should be checked carefully before being stored and during the pre-use check by passing them through the hands to combine a tactile and visual examination. Kernmantel ropes should be checked to see that the sheath has not been cut and by feeling the rope for any damage to the core. Cable-laid ropes should be carefully twisted open at intervals along their length to inspect for internal damage. Harnesses and webbing should be checked for cuts, abrasions, broken stitches and undue stretching.

**2.10.2.7** Man-made fibres deteriorate slowly with age regardless of use and this ageing is accelerated by heavy and dynamic loadings. However, the most common cause of strength loss in equipment made from man-made fibres is through abrasion (either by grit working into the strands of webbing or rope or by chafing against sharp or rough edges) or by other damage, such as cuts.

**2.10.2.8** Equipment made from man-made fibres should be carefully and regularly inspected for signs of abrasion. This applies to both external abrasion and internal abrasion. External abrasion is easy to see but sometimes it is difficult to determine the extent of its detrimental effect. Internal abrasion is more difficult to spot but can often be substantial, particularly if grit has penetrated the outer surface. All levels of abrasion lower the strength of this equipment: as a general rule, the greater the abrasion the greater the loss of strength. The effects of UV degradation and abrasion combined weaken the materials even further.

**2.10.2.9** To minimize grit content, or simply to keep the product clean, soiled items should be washed in clean water (maximum temperature 40 °C) with pure soap or a mild detergent (within a pH range of 5.5 to 8.5), after which they should be thoroughly rinsed in cold, clean water. The use of a washing machine is permissible but it is recommended that the equipment be placed in a suitable bag to protect against mechanical damage. Wet equipment should be dried naturally in a warm room away from direct heat.

**2.10.2.10** Internal abrasion can also occur without any ingress of grit, simply by the action of the fibres rubbing together when flexing during normal use. For most textile materials, this is a slow process and is not significant. An exception is material made from aramid, which is very susceptible to this type of damage.

**2.10.2.11** Equipment made from man-made fibres that have been in contact with rust should be washed. Such equipment with permanent rust marks should be regarded as suspect and scrapped. Tests have indicated that rust may have a weakening effect on polyamides.

**2.10.2.12** Any component with a cut or substantial abrasion should be scrapped. The presence of a few small loops of fibres pulled up from the surface (plucks) is not a cause for concern. However, plucks can be susceptible to snagging, thereby causing additional damage, and should be kept under observation.

**2.10.2.13** It is essential to avoid contact with any chemical that could affect the performance of the equipment. These include all acids and strong caustic substances (e.g. vehicle battery acid, bleach, drilling chemicals and products of combustion). The equipment should be withdrawn from service if contact does occur or is even suspected. Vigilance is necessary as contamination can come from unusual sources. In a climbing fatality in France, the effect of formic acid emitted by ants was cited as part of the reason for the failure of the climbing rope.

**2.10.2.14** Deterioration in ropes from contact with chemicals, or from mechanical damage, is often localized and not obvious, and can be missed during inspection. Chemical deterioration is often not

detectable visually until the component starts to fall apart. The safest course of action is to scrap any component about which there is any doubt. Proof load testing should not be carried out on components made from man-made fibres.

**2.10.2.15** Anchor lines, webbing or harnesses which have glazed or fused areas could have suffered excessively high temperatures and are suspect. If the fibres appear powdery or if there are changes in colour in a dyed component, this can indicate severe internal wear or contact with acids or other damaging chemicals, or it can indicate ultra-violet degradation. Swellings or distortion in a rope can be a sign of damage to the core fibres or of movement of the core within the sheath. Cuts, chafes, plucking and other mechanical damage weaken ropes and webbing, the degree of weakening being directly related to the severity of the damage. Loosening or excessive breaks in the yarns could indicate internal wear or cuts. Advice should be sought from the supplier or manufacturer, but if there is any doubt as to the condition of the equipment, it should be scrapped.

**2.10.2.16** Most man-made fibres are affected by high temperatures and begin to change their character, and thus their performance, at temperatures exceeding 50 °C. Therefore, care should be taken to protect against this. (The rear parcel shelf of a car in hot weather, for example, can exceed this temperature.)

**2.10.2.17** Equipment made from man-made fibres should not normally be dyed, except by the manufacturer. Many dyes contain acids or require the use of acids to fix the colour permanently to the fibres, which could cause strength losses of up to 15 %.

### **2.10.3 Metal equipment**

**2.10.3.1** Most metal equipment, e.g. connectors; descending devices; ascending devices, is made of steel or of aluminium alloys, although other metals, such as titanium, are sometimes used. Aluminium alloys and most steels, with the exception of stainless steel, all look the same. However, the performance of these metals can vary greatly, particularly in terms of their corrosion resistance. It is essential, therefore, that the user knows from what the equipment is made, so that relevant precautions can be taken.

**2.10.3.2** Equipment made from aluminium alloys sometimes has a polished surface finish, but usually it is anodized. Anodizing provides a thin electrochemical coating, which is harder than the base material. This coating protects the base metal against corrosion and also, to a small extent, against wear.

**2.10.3.3** The various aluminium alloys used in rope access equipment have different characteristics. Generally, the stronger the alloy, the more susceptible it is to corrosion, so greater care in use, maintenance and inspection is required. Aluminium alloys are particularly susceptible to corrosion when in contact with seawater.

**2.10.3.4** Contact between different metals can cause galvanic corrosion to occur, especially when wet, as a result of electrolytic action. This is one reason why equipment should not be stored wet (see **2.10.7**). Galvanic corrosion can affect many metals, including aluminium and some stainless steels and can cause the rapid destruction of protective coatings such as zinc. Long term contact of dissimilar metals (e.g. copper and aluminium) should be avoided, especially in wet conditions and, in particular, in a marine environment.

**2.10.3.5** Some metals that are under tensile stress and in a corrosive environment can develop surface cracks. This is known as stress corrosion cracking. It is time dependent and can take many months to become apparent. This highlights why the need for regular inspection of equipment is so important.

**2.10.3.6** Metal items such as rings, buckles on harnesses, connectors and descending devices require checking to ensure that hinges etc. work smoothly, bolts and rivets are tight and to look for signs of wear, cracks, deformation or other damage. They should be kept clean and, when dry, moving parts should be lubricated using a light oil or silicone grease. Lubrication should be avoided in areas that might come into contact with webbing fastening straps (for example, the slide bar of a

harness buckle), ropes, slings, etc. because it could affect the proper functioning of any fastening arrangement. Any item showing any defect should be taken out of service.

**2.10.3.7** Equipment made totally from metal can be cleaned by submerging in clean, hot water containing detergent or soap for a few minutes. High-pressure steam cleaners should not be used because the temperature could exceed the recommended maximum of 100 °C. Seawater should not be used for cleaning. After cleaning, the equipment should be thoroughly rinsed in clean, cold water and then dried naturally away from direct heat.

**2.10.3.8** Some chemical products used in building work can cause excessive corrosion to items made of aluminium alloys. Advice on dealing with this should be obtained from the product manufacturer.

#### **2.10.4 Protective helmets**

The shells of protective helmets should be checked for cracks, deformation, heavy abrasion, scoring or other damage. The chinstraps and cradles should be checked for wear, as should the security of any attachment points between different elements, such as sewn or riveted areas. Any helmet showing any defect should be taken out of service. Helmets made from polycarbonate should not have stickers placed on them unless it has been confirmed by the manufacturer that it is safe to do so. This is because the solvent used in the adhesive of some stickers can detrimentally affect the polycarbonate.

#### **2.10.5 Disinfection of equipment**

It may be considered necessary to disinfect equipment, for example after working in a sewer, although normally cleaning as described in **2.10.2.9** or **2.10.3.7** is sufficient. There are two things to consider when choosing a disinfectant: its effectiveness in combating disease and whether or not there will be any adverse effect on the equipment after one or several disinfections. Advice should be sought on these two points from the manufacturer or supplier of the equipment before carrying out any disinfection. After disinfection, the equipment should be rinsed thoroughly in clean, cold water and then dried naturally in a warm room away from direct heat.

#### **2.10.6 Equipment exposed to a marine environment**

If used in a marine environment, equipment should be cleaned by prolonged immersion in clean, cold fresh water, then dried naturally in a warm room away from direct heat and inspected before storage.

#### **2.10.7 Storage**

After any necessary cleaning and drying, equipment should be stored unpacked in a cool, dry, dark place in a chemically neutral environment away from excessive heat or heat sources, high humidity, sharp edges, corrosives, unauthorized access, rodents, ants (which emit formic acid) or other possible causes of damage. Equipment should not be stored wet because of the possibility of fungal attack or corrosion.

#### **2.10.8 Equipment withdrawn from service**

**2.10.8.1** It is important that there is a quarantine procedure for ensuring defective or suspect equipment that has been withdrawn from service does not get back into service without the inspection and approval of a competent person.

**2.10.8.2** Equipment found to be defective at inspection, or if its serviceability is compromised or in doubt, should be withdrawn from service and referred for further inspection or repair. Such equipment should be marked as not fit for service and, if not repairable, should be destroyed to ensure it cannot be used again. Records should be updated immediately.



## **2.10.9 Lifespan**

**2.10.9.1** It is very difficult to know by how much equipment is deteriorating (particularly equipment made from man-made fibres), without testing to destruction, which rather defeats the objective. Therefore, it is advisable to set a period after which such equipment should no longer be used. This period is known as the lifespan. The information supplied by the manufacturer for the equipment should be referred to when deciding on the lifespan. It is also important that a history is kept of the use of equipment, which should ideally log the conditions in which it was used, as this could be useful in any review of the lifespan set for the equipment.

**2.10.9.2** Some equipment is given a lifespan (e.g. an obsolescence date) by the manufacturer. Equipment that has reached such a limit and has not already been rejected for another reason should be withdrawn from service and not used again, unless or until confirmed by a competent person, in writing, that it is acceptable to do so. Records should be updated immediately.

## **2.10.10 Alterations to equipment**

Equipment should not be altered without the prior approval of the manufacturer or supplier because its performance might be affected.

## 2.11 Primary rope access work methods

### 2.11.1 Double protection

**2.11.1.1** A rope access system actually consists of an access (sub) system and a back-up (sub) system, which are used together. The access system provides the primary support for access, egress and work positioning. It comprises a working line and descending and ascending devices, which are attached to the working line and which are always connected to the rope access technician's harness. The back-up system provides security additional to that provided by the access system, e.g. should there be a failure of the access system. The back-up system comprises a safety line and a back-up device, which is attached to the safety line and which is always connected to the rope access technician's harness. This system of double protection, which was developed by IRATA International, is one of the key elements of a safe rope access system.

*NOTE* For an example of a typical method of ascending and descending using IRATA International rope access techniques, see **Part 3, Annex K**.

**2.11.1.2** The working line and the safety line are known collectively as anchor lines. Each anchor line should be attached to its own anchor point. The working line and the safety line are normally connected to each other for added security, as well as allowing the anchor lines to be positioned between the anchors. Load sharing between anchors reduces the load on each one. This minimizes the likelihood of failure of either anchor but, in the unlikely event of a failure of one of them, there would only be a minimal impact force on the second anchor. A single element of a structure, (e.g. structural steelwork), a natural geological feature or a tree might have adequate strength to provide a place for anchor points for both the working line and the safety line. This should be verified by a competent person. Rope access safety supervisors are responsible for checking that anchor lines are correctly rigged. See **Figure 2.5**.

**2.11.1.3** The principle of double protection also applies to the attachment of rope access technicians via their anchor line devices to the working line and safety line and to any anchors by their anchor lanyards. For example, descending devices and back-up devices should be fixed to the rope access technician's harness with separate connectors, in accordance with the information supplied by the manufacturer. (It is not necessary to wear two harnesses).

**2.11.1.4** Rope access technicians normally descend the working line by means of the descending device, with the back-up device attached to the safety line. During ascent, ascending devices are attached to the working line, with the back-up device attached to the safety line. During both ascent and descent, the back-up device should be positioned so that the distance of any potential fall and its consequences are minimized. The system can be modified to become a top rope protection, where particular supervision or care of the rope access technician is required.

*NOTE* Sometimes, rope access methods are used in conjunction with conventional suspended access equipment. In such cases, the principle of double protection still applies to the rope access work. The anchors for rope access should be independent of the anchors for the conventional suspended access equipment. For the safety requirements for work on conventional suspended access equipment, reference should be made to the appropriate standards.

**2.11.1.5** When carrying out rope access manoeuvres, e.g. passing a re-anchor; passing a knot, the action should be carried out in such a way that at least two independent points of attachment are maintained at all times.



a) Example of two equally loaded anchors

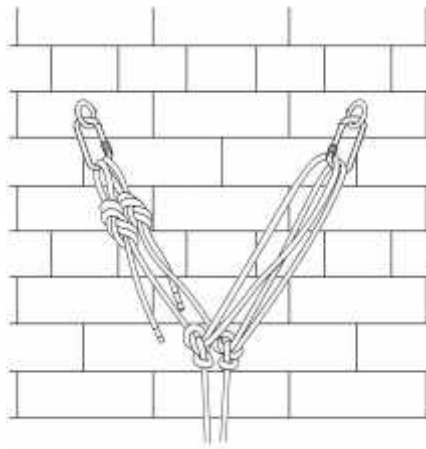

b) Example of double protection being provided by the use of eyebolts



**Key**

- 1 Structural steel
- 2 Anchor sling

c) Example of double protection being provided by the use of anchor slings

**Figure 2.5 — Typical arrangements in a rope access anchor system**

## 2.11.2 The anchor system (anchors and anchor lines)

**2.11.2.1** The anchor system is of primary importance in the rope access system and should be unquestionably reliable.

**2.11.2.2** When selecting, positioning and using anchors, the principle of double protection (see **2.11.1**) applies and, therefore, at least two independent anchors, i.e. at least one for the working line and at least one for the safety line, should always be used.

**2.11.2.3** The recommendation to use two independent anchors applies even when attachment is to be made to an anchorage (i.e. a structure or natural feature) where it is apparent that the anchorage has more than adequate strength, e.g. a large steel beam.

**2.11.2.4** Anchors should be positioned in such a way that rope access technicians can maintain their work position without difficulty and so that connection can be made to or from the rope access system in an area where there is no risk of a fall from a height.

**2.11.2.5** The foreseeable directions of loading and anticipated potential loads should be established and taken into account when setting up the anchor system.

**2.11.2.6** To determine the minimum anchor strength recommendation, this code of practice uses a safety factor of 2.5. The maximum impact load on the user in the event of a fall should not exceed 6 kN; therefore, as a general rule, the static strength of anchors, with the exception of some deviation anchors, should be at least 15 kN.

*NOTE The anchor may yield but should not fail at this load.*

**2.11.2.7** There is no requirement for designers (e.g. building designers) to add a further safety factor but, of course, the static strength may be increased if it is considered prudent or necessary to do so.

**2.11.2.8** The values have been determined assuming a rope access technician with a mass, including equipment, of 100 kg, which is a typical standard test mass used in product standards for personal fall protection equipment. Rope access technicians with a mass that is greater than 100 kg including equipment should take appropriate steps to ensure that their anchors are of sufficient strength, e.g. by ensuring that there is sufficient energy absorption in the anchor system to keep the impact load on them and the anchors down to 6 kN or less in the case of any fall, and/or by increasing the strength of the anchors above the recommended minimum of 15 kN.

*NOTE The recommendations regarding situations where the mass could be more than 100 kg applies especially in the case of rescue, where there could be more than one person attached to the anchor system. However, during rescue, IRATA rope access technicians are required and trained to follow procedures which restrict the potential for dynamic loading of the anchor system.*

**2.11.2.9** Wherever feasible, the two independent anchors – one for the working line and one for the safety line, and each with a static strength of 15 kN or more – should be linked together for added security. This link can be achieved, for example, by the use of a double figure-of-eight knot on the bight (also known as a bunny knot) or a combination of a figure-of-eight knot on the bight and an alpine butterfly knot, see **Figure 2.6a**.

**2.11.2.10** Where the minimum recommended static strength of 15 kN for a single anchor is not achievable, it is acceptable to link together a number of anchors of a lower static strength, e.g. by the use of a Y hang, to act effectively as a single independent anchor for either the working line or the safety line, as long as the load on each group of anchors is equally shared and the combined static strength is a minimum of 15 kN, see **Figure 2.6b**. To allow for foreseeable misuse, e.g. unequal loading, it is recommended that the minimum static strength of each anchor in this combination is 10 kN.

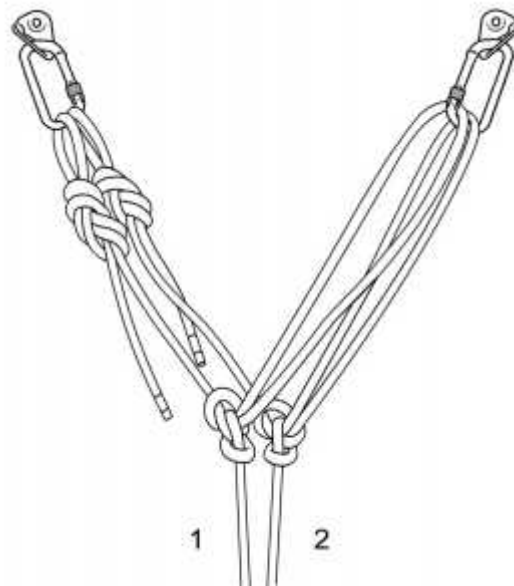

a) Example of a Y hang arrangement where the strength of each individual anchor is 15 kN or greater

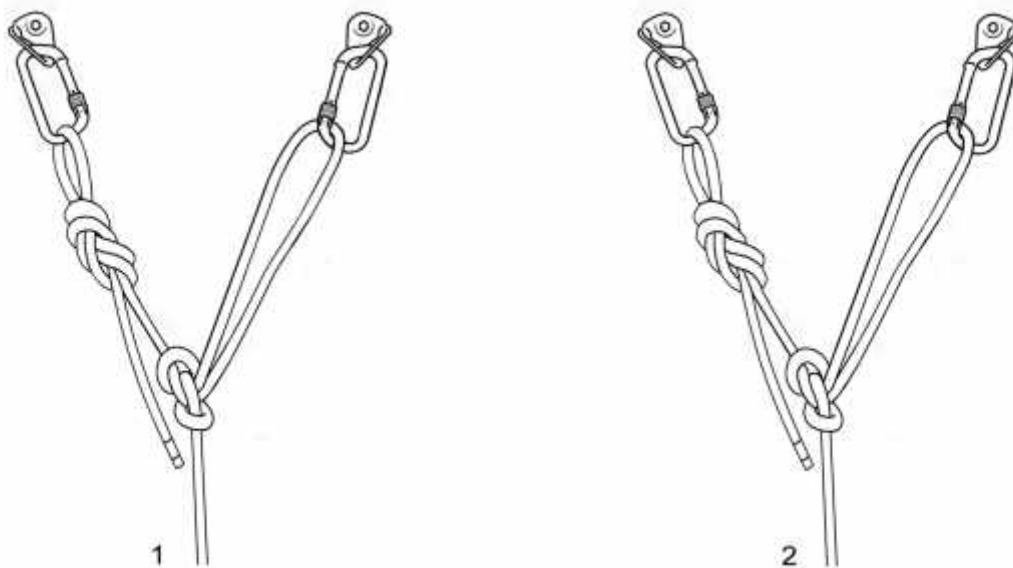

b) Example of a Y hang arrangement where the strength of each individual anchor is less than 15 kN and is equal to or greater than 10 kN

**Key**

- 1 Working line
- 2 Safety line

**Figure 2.6 — Typical arrangements in a rope access anchor system to achieve minimum strength recommendations**

**2.11.2.11** The contained angle formed by the ropes linking the anchors in a Y hang (the Y angle) should be as low as possible and should generally not exceed 90°. This is the *preferred maximum angle*, see **Figure 2.4**. The greater the angle beyond this, the weaker the connection will be. If circumstances dictate the need for an angle greater than 90°, account should be taken of the increased loads at the anchors, at the anchor line terminations and on other components in the system. The angle should not exceed 120° because at angles greater than 120° the loads increase very significantly. There is an exception to this advice on preferred-maximum and maximum Y angles, which concerns flexible horizontal anchor line systems. These systems require special expertise to set up and use safely. Also see **2.11.2.21**. Further information is provided in **Part 3, Annex L**.

**2.11.2.12** Anchors of the type that are fixed in masonry should only be installed (and inspected) by competent persons, who are aware of the numerous safety issues, e.g. minimum distance required between two fixed anchors, minimum distance from any edge, correct depth, solid or hollow masonry. Where possible, anchors should always be installed so that they are loaded in shear. For safety considerations when installing anchor devices, see **Part 3, Annex F**.

**2.11.2.13** Anchor slings, which typically are used where there are no suitable anchors to which the ropes can be attached directly, should have a minimum breaking strength of 22 kN if they are made from man-made fibres and a minimum breaking strength of 15 kN if they are made from steel wire or chain. In the USA, the minimum breaking strength for both textile and metal anchor slings is 5000 lbs.

**2.11.2.14** Anchor slings intended to be looped through themselves (known as lark's-footing or choking) should be strong enough to allow for the weakening effect. Lark's footing should generally be avoided, unless the anchor sling and the structure or natural feature to which it is to be attached are known to be suitable. See **Figure 2.7**.

**2.11.2.15** Where the anchor system comprises one or more anchor slings, care should be taken to ensure that their intended position is maintained at all times and that, when a load is applied, they cannot slide out of place vertically or horizontally, e.g. on a smooth linear structure such as a steel beam, or a tree trunk. Examples of ways to prevent ropes or anchor slings sliding are:

- a) a webbing sling choked around a structure (i.e. where one side is threaded through the other) provides more friction than one simply passed around it, but also causes a loss of strength in the sling. Wide slings usually provide more friction than narrow slings. Slings used for choking should be designed for this application;
- b) a rope wrapped several times around the structure or natural feature or a multi-wrapped sling is likely to have more friction than a single loop;
- c) a link to another opposing anchor to prevent sliding.

**2.11.2.16** If anchors are placed for permanent use, they should be clearly marked with:

- a) the manufacturer's/installer's name and contact details;
- b) service/inspection details, e.g. due date for the next inspection;
- c) the maximum rated load;
- d) the intended direction of loading;
- e) the need for users to read the instructions for use.

**2.11.2.17** The static strength of each anchor line including terminations (all types, e.g. sewn and knotted) should be a minimum of 15 kN.

**2.11.2.18** When it is necessary to re-anchor an anchor line, e.g. to avoid abrasion or to allow a change of direction, the anchors should be installed or placed so that any potential loads are in shear. Where installation is only possible such that any forces on them would be axial, account should be

taken of any reduction in strength caused by such placement and of any advice or limitations given by the anchor manufacturer.

**2.11.2.19** Where anchor lines need to be redirected, the angle and loading at the deviation anchor and supporting equipment used should be taken into account before use, together with what might happen in the case of failure. Failure could cause an out-of-control swing fall (a pendulum), which could result in injury to personnel or damage to equipment or property. An example of the effect of the angle on the loading is given in **Figure 2.8**, based on a mass of 100 kg (which is equivalent to a force of approximately 1 kN). Masses smaller or larger than this would give different loadings from those shown in the example. A large deviation angle could increase the difficulty for the rope access technician in manoeuvring past the deviation anchor, so a re-anchor might be more appropriate.

**2.11.2.20** Where anchor lines are rigged some distance apart and failure of one could lead to a large pendulum and subsequently an impact with the structure or natural feature, the use of two anchors for each anchor line is recommended, see **Annex F, Figure F.11**.

**2.11.2.21** When anchor lines are tensioned, for example, as they are in horizontal anchor line systems, the increased loads in the system, e.g. at the anchor, anchor line terminations and at other components, should be taken into account. An incorrectly tensioned system can result in loads that are potentially catastrophic. The loads in these systems should be calculated by a competent person before use and any other necessary checks and adjustments should be made to ensure that the system is safe.

**2.11.2.22** Rope access technicians and rescue services should be aware that additional anchors may be required to facilitate workmate retrieval.

**2.11.2.23** Where rope access techniques are carried out from suspended platforms, anchors for the rope access technicians' anchor lines should be totally separate from those used for the platform.

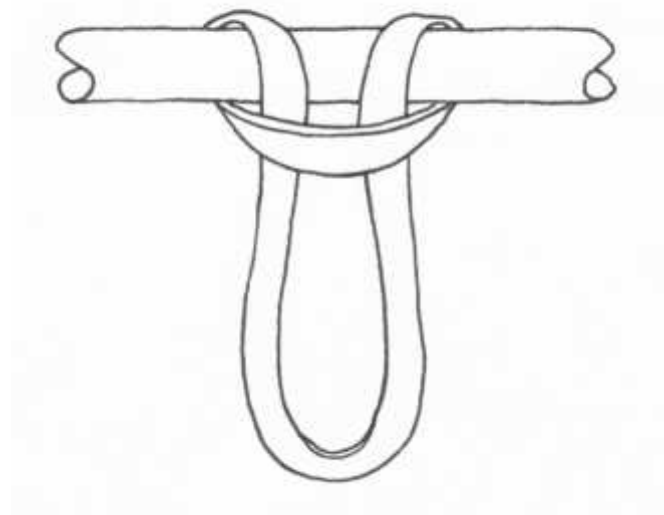

**Figure 2.7 — Example of a lark's-foot (choked) sling**

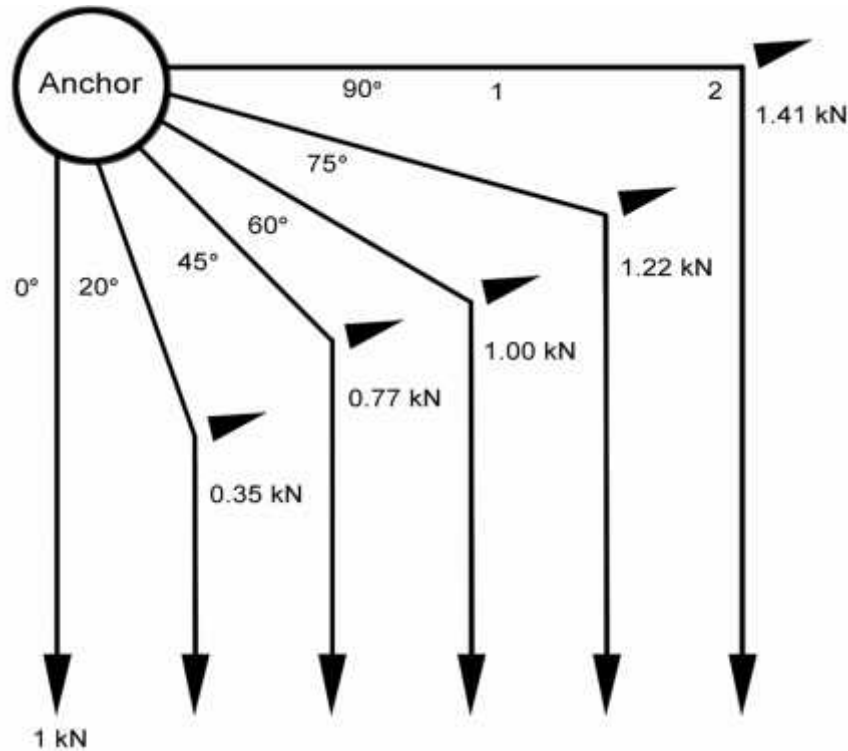

**Key**

- 1 Anchor line
- 2 Position of deviation anchor

**Figure 2.8 — Example of how the angle at a deviation anchor affects its loading**

### 2.11.3 Use of anchor lines

#### 2.11.3.1 Rigging and de-rigging

2.11.3.1.1 Anchor lines should be rigged to avoid any surface that could damage them (see 2.7.10).

2.11.3.1.2 Rope access technicians should not ascend or descend any anchor lines without confirmation from the rope access safety supervisor that it is safe to do so, following pre-descent/pre-ascent checks.

2.11.3.1.3 Rope access technicians should normally descend vertically with the minimum amount of swing (pendulum) to minimize the risk of abrasion to the anchor line or putting unnecessary stress on it or the anchors.

2.11.3.1.4 On long descents, anchors providing lateral restraint (e.g. deviation anchors) could be fitted on the anchor lines to enable the rope access technicians to maintain their position without being buffeted too much by the wind.

2.11.3.1.5 Deviation anchors are also used to avoid hazards, e.g. sharp edges; hot surfaces. They should be robust enough not to fail at any potential load to which they could be subjected (see Figure 2.8).

2.11.3.1.6 The effects of wind on the free end of anchor lines should be taken into account. Care should be taken to ensure that the tail end of anchor lines cannot snag on dangerous objects, such as



working machinery, power lines or a moving vehicle. This could lead to the need for additional monitoring.

**2.11.3.1.7** The placing of any excess anchor line for the descent in a bag and suspending it beneath the rope access technician can prevent anchor lines from becoming entangled or damaged by any falling debris, e.g. when removing rock during slope stabilization, but checks should be made first to ensure the anchor lines are long enough. In such situations, care is necessary to remove loose material before descending and it is important to be aware of the possibility that any movement of the anchor line could dislodge material above, which could fall onto the rope access technician. Steps should be taken to remedy this, e.g. by the use of containment netting.

**2.11.3.1.8** Bags used to contain and suspend anchor lines (and other equipment) at height should be equipped with appropriate attachment points and should be of sufficient strength to ensure they do not fail when subjected to anticipated loads. Rope access technicians should take precautions to ensure that bags cannot snag on objects and potentially increase the load on the bag attachment points.

**2.11.3.1.9** Anchor lines are particularly vulnerable to damage caused by abrasion, cutting, melting or chemical contamination. Damage can be exacerbated by vertical or horizontal movement of the anchor lines, especially when they are under load, such as when a rope access technician is ascending, descending, making sideways movements or in a fall. Contact with any potentially hazardous surface should be avoided but, where this is not possible, e.g. where it is not possible to rig a free hang, it is essential that anchor lines are adequately protected. For more information on edge and anchor line protectors and protection, see **2.7.10** and **2.11.3.2**.

**2.11.3.1.10** Damage by chemical contamination is often not easily noticed, so frequent and assiduous checking is strongly recommended when working in areas where the risk of contamination by chemicals is suspected, see **2.10.2**. For information on the resistance to chemicals of some man-made fibres, see **Part 3, Annex J**.

**2.11.3.1.11** Anchor lines should be configured so that a rope access technician cannot inadvertently descend off the end of them. Where the anchor line is free hanging, this may be achieved by the use of a simple stopper knot (see **Figure 2.9**). The stopper knot should be properly dressed and then set (i.e. hand tightened). After the knot has been set, the length of the tail below the knot should be at least 300 mm. In use, care should be taken to ensure the knot cannot become snagged with potential obstructions (see the examples given in **2.11.3.3**). It should be understood that a simple stopper knot is unlikely to arrest an out-of-control descent, e.g. when the user has lost control of their descending device and the descent is effectively a fall. If it is thought necessary to protect against such a possibility, a proven stopper system, e.g. one incorporating a stopper disc that has been tested with the descending device being used, should be fitted to the anchor line.

**2.11.3.1.12** If exit from the bottom of the anchor lines is planned, a check should be made to ensure that the anchor lines reach the bottom, or if being carried in a bag, that they are long enough. It may require a sentry or grounds-man to check this.

**2.11.3.1.13** Slack in the safety line should always be avoided to minimize the length of any potential fall.

**2.11.3.1.14** To minimize the length of any potential fall, connections to safety lines should, wherever possible, always be positioned above the rope access technician's harness attachment point, with the least amount of slack achievable in the device lanyard. This may not be possible with back-up devices intended to follow the user. However, in all cases, when the rope access technician is not in motion, the back-up device should be positioned as high as possible.

**2.11.3.1.15** Attaching to or detaching from anchor lines at mid-height may present problems. Anchor lines should be checked carefully to ensure there is no build-up of slack between the anchors and attachment point that could become snagged and release suddenly. Where the whole length of the anchor lines can be seen, these checks can be visual. When the anchor

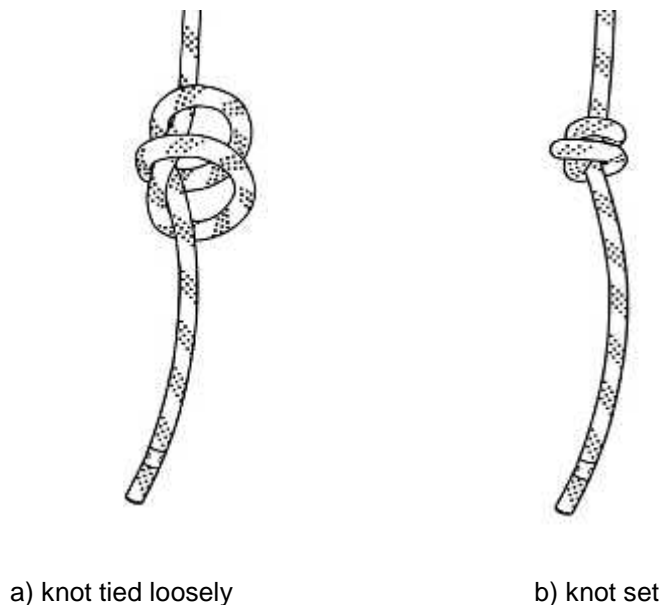

**Figure 2.9 — Example of a stopper knot for use at the end of anchor lines (in this example, half a double fisherman's knot)**

lines are not fully visible, the checks should be physical, e.g. by carrying out a descent from the top (preferable) or by pulling and shaking the anchor lines from either end.

**2.11.3.1.16** Where there are long anchor lines above a short drop, previously unloaded anchor lines may stretch suddenly when loaded, allowing a rope access technician to drop a distance proportional to the length of anchor line above, possibly causing him/her to hit an obstruction or the ground. In addition, if the working line were to fail at this point, the stretch generated in the safety line could result in insufficient protection, irrespective of the type of back-up device used. A solution is for the rope access technician to re-anchor both anchor lines and thus remove the problems of excessive elongation.

**2.11.3.1.17** On sloping surfaces such as rock slopes, or on pendulums, care should be taken to avoid anchor lines snagging, e.g. during any lateral movement to be followed by a further descent. If the rope becomes un-snagged during these manoeuvres, e.g. if the feature causing the anchor lines to snag fails or if the anchor lines slip off it, the rope access technician could fall as the rope is released and it reverts to being in a straight line with the anchor – see **Figure 2.10**.

**2.11.3.1.18** The use of anchor lines to haul equipment should be avoided or great care taken to avoid mid-rope snagging if they are lowered again for further use. Dangerous snagging may be prevented by tying equipment in the centre of the rope and using the lower half as a back-rope to keep the equipment away from the surface of the slope or structure.

**2.11.3.1.19** In some unusual circumstances, wet anchor lines may become a tracking path for electrical discharges. In such circumstances, suitable precautions should be taken, e.g. temporarily stop work if electrical storms are imminent.

**2.11.3.1.20** If anchor lines are to be left unattended, e.g. if work extends over one day and anchor lines are to be left in place, precautions are necessary to avoid abrasion or chafing to them caused by repeated movement and contact with hazardous surfaces due to the wind. The anchor lines could be

pulled up and bagged while still being left anchored, or could be sufficiently tensioned to prevent abrasion.

**2.11.3.1.21** Before any anchor lines are de-rigged, it is essential that all members of the team confirm that they are safe and aware that de-rigging is about to take place.

### **2.11.3.2 Protection methods for anchor lines**

**2.11.3.2.1** It is essential that precautions are taken to prevent damage to anchor lines, when they are in use. See **2.7.10** for advice on the selection of protectors for anchor lines and **Annex P** for recommended actions for the protection of anchor lines.

**2.11.3.2.2** The potential for movement of the anchor lines in both the vertical and horizontal planes while in use should be taken into account when assessing the surface to be protected against, the choice of protection to be used and where the protection is to be positioned.

**2.11.3.2.3** Wherever feasible, any hazard that could cause damage to the anchor lines should be removed. If this is not possible, anchor lines should be rigged so that they hang free for their entire length and for the duration of the rope access task, and do not contact or have the potential to contact edges, or abrasive or hot surfaces.

**2.11.3.2.4** Where anchor lines cannot be rigged to hang free directly from their anchors, they should be suitably protected. One way of achieving this is by the use of a specific engineered solution, such as a scaffolding barrier made from smooth undamaged tubing over which the anchor lines can run and which is positioned to keep the anchor lines well away from the hazard(s). Other options are the use of *edge protectors* and *anchor line protectors*. A combination of more than one type of protector may sometimes be necessary to provide adequate protection.

**2.11.3.2.5** Edge protectors, e.g. commercially-made rollers; metal edge plates; other cut-resistant or heat-resistant edge protectors, with large radius surfaces offer the best protection at any edge in a drop. These devices should be equipped with a means of maintaining their intended position. Suitably arranged scaffold tubing, heavy-duty carpet (with a high natural fibre content, such as wool) or thick canvas padding can also offer good protection and are commonly used.

**2.11.3.2.6** Anchor line protectors, which typically comprise a sheath made of a suitable material which encapsulates the anchor line, may be used to protect the anchor lines against contact with abrasive or hot surfaces (but not edges).

**2.11.3.2.7** Great care should be taken when choosing an anchor line protector that it is going to offer sufficient protection against the surface with which it may be in contact. It should be able to withstand use in the chosen location without wearing through or melting and exposing an anchor line to the abrasive or hot surface. Anchor line protectors used to protect against hot surfaces should be of a type intended for this purpose.

**2.11.3.2.8** It should be noted that some anchor line protectors can obscure the anchor lines from view and thus make it difficult or impossible to see whether or not damage is being caused to them, e.g. because the anchor line protector has been worn through.

**2.11.3.2.9** Anchor line protectors made from a single or even double thickness of material might not offer sufficient protection against sharp edges and are not recommended for such use unless the manufacturer specifically states in the user information that they are.

**2.11.3.2.10** The use of anchor line protectors made from polyvinyl chloride (PVC) coated textiles should be avoided where the design is such that this material is in direct contact with the anchor line, due to potential heat caused by friction, which can cause melting of the PVC.

**2.11.3.2.11** If anchor line protectors are to be used to protect against surfaces that are significantly abrasive or if they are to be used to protect against hot surfaces, it is recommended that each anchor line is protected by its own anchor line protector, unless the manufacturer states otherwise or unless

there is another good reason not to do so. In the event of the failure (e.g. wearing through) of a single anchor line protector which is being used for both anchor lines, damage is likely to be caused to both anchor lines at the same time, with the potential for a catastrophic failure of both if an incident were to occur, e.g. a fall.

**2.11.3.2.12** Where one anchor line protector is used for both anchor lines, and is to be tethered to an anchor line rather than to the structure, it is normally attached to the safety line only, as the safety line is less likely to stretch than the working line, thus minimising the chance of accidental abrasion.

**2.11.3.2.13** Sometimes, it may be appropriate to rig the safety line in a position away from the working line, e.g. to avoid any potential hazardous area and the possibility of both the working line and the safety line failing simultaneously. If the working line and the safety line are some distance apart, an anchor line protector should be used for each anchor line.

**2.11.3.2.14** In mid-anchor line situations, attachment of an anchor line protector to the structure or natural feature rather than to the anchor line is preferable, as anchor line elongation could result in poor protection or no protection at all if the anchor line protector is fastened to the anchor line. If exit is to be from the bottom of the anchor lines but retrieval of the anchor lines is to be from the top, the anchor line protector should be fastened to the anchor line.

**2.11.3.2.15** It is essential that edge protectors and anchor line protectors maintain their intended position. Care is necessary to ensure the edge protector or anchor line protector remains in the correct place when the anchor line is loaded, or that it is repositioned correctly when more than one person uses the anchor line. This may be particularly relevant if users are of different weights (masses). The consequences of a failure of the working line and the subsequent elongation of the safety line should be taken into account, which may prompt the use of several edge protectors or anchor line protectors.

**2.11.3.2.16** Edge protectors and anchor line protectors of a type that can be located on the anchor lines anywhere along them (e.g. without having to thread the end of an anchor line through the edge protector or anchor line protector) are generally recommended. Anchor line protectors that have a touch-and-close system of fastening are useful when attaching to an anchor line part way down a drop. They are usually provided with a thin cord so that they can be fixed to the structure, natural feature or anchor line. One design of anchor line protector simply grips the anchor line by friction to keep it in place.

## **2.11.4 Additional safety measures**

Rope access systems should be configured and used in such a way to prevent falls. Nevertheless, consideration should be given to the unlikely event of a fall, e.g. in the case of incorrect use or failure of a piece of equipment. Some of the points below are made in other sections of this code of practice but are repeated here for reinforcement. Rope access systems should be configured to ensure:

- a) any potential fall distance is minimized, e.g. slack in the anchor lines is avoided or minimized (for information on fall factors, fall distances and associated risks, see **Part 3, Annex Q**);
- b) adequate clearance distance is provided, so that the rope access technician is prevented from impacting with the ground or obstacle in the path of a fall (e.g. allow for the extension of an energy absorber during deployment or elongation of the safety line);
- c) any swing fall (pendulum) is kept to an acceptable minimum;
- d) the maximum impact load a rope access technician could experience is as low as possible and never any greater than 6 kN;
- e) adequate protection is provided for anchor lines and other equipment in the system to prevent them from failure during use and during a fall, its arrest or post-fall suspension;
- f) following an incident, rope access technicians are likely to be in a position to rescue themselves;

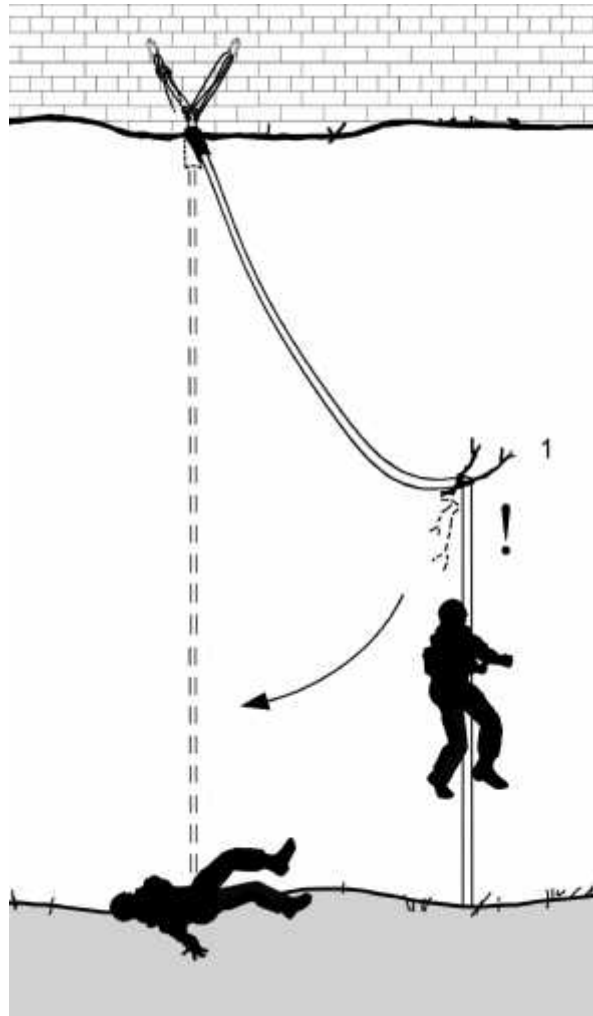

**Key**

- 1 Anchor lines inadvertently snagged on a protuberance (could be natural or structural)

**Figure 2.10 — Example of the potential danger of snagged anchor lines**

- g) anchor lines are configured so that if workmate retrieval becomes necessary, it can be readily carried out in a timely fashion;
- h) rope access technicians are never left working on their own, so that, in the event of an incident, the workmate retrieval procedure can begin without delay;
- i) there are plans in place to cater for potential incidents, which include:
  - (i) methods of communication;
  - (ii) appropriate equipment, which may include, depending upon the risk assessment, a pre-rigged rescue system;
  - (iii) methods of contacting rescue services that may be required and how they will be guided to the correct position on site;

(iv) for all team members, the means to travel up and down the anchor lines and to be able to carry out a rapid workmate retrieval.

### 2.11.5 The use of knots

**2.11.5.1** Knots are used typically to form terminations in textile anchor lines and there are many that are suitable for use in rope access. Although knots reduce the overall strength of a rope (which should be taken into consideration when choosing a rope), one benefit is that they absorb energy. Some knots absorb more energy than others. An example of a knot that is particularly good at absorbing energy is the scaffold knot, which is often used to terminate an anchor lanyard.

**2.11.5.2** It is essential that rope access technicians should be able to tie, dress and set appropriately a range of the most commonly used knots and to be confident that they will be able to tie them when in difficult circumstances. In the workplace, knots should only be tied by persons with a thorough knowledge of knots and knot-tying techniques.

**2.11.5.3** When choosing a suitable knot, rope access technicians should take into account the following:

- a) their own skill in tying that particular knot;
- b) the suitability of the knot for the task and the anticipated way in which it may be loaded, including the potential forces envisaged;
- c) the reduction of strength in the anchor line, device lanyard or anchor lanyard that the knot creates;
- d) the ease with which the knot may be tied and untied;
- e) where required, the ability of the knot to pass through or over potential obstructions, e.g. pulleys.

**2.11.5.4** The tails of all knots should be at least 100 mm long, once the knot has been set. Knots should never be tied in anchor lines made from wire rope.

**2.11.5.5** The reduction in the strength of the rope caused by the knot varies, dependent upon the type of knot and the accuracy and neatness with which it is tied. Neatening a knot, e.g. making sure the ropes in the knot are parallel and tightened equally, is known as *dressing*. Typical strength losses, showing the lower and upper values between a well-dressed knot and a poorly-dressed knot, are:

- a) scaffold knot: 23 % to 33 %;
- b) figure-of-eight on a bight: 23 % to 34 %;
- c) figure-of-nine on a bight: 16 % to 32 %;
- d) figure-of-ten on a bight: 13 % to 27 %;
- e) overhand on the bight: 32 % to 42 %;
- f) double figure-of-eight on the bight (bunny knot): 23 % to 39 %;
- g) alpine butterfly: 28 % to 39 %;
- h) bowline: 26 % to 45 %.

## 2.11.6 Work teams

**2.11.6.1** A work team comprises a rope access team, i.e. the rope access technicians participating in the rope access work, and any supporting personnel. Because of the locations and the specialized nature of the work, all work teams should be properly supervised and be self-supportive, e.g. with respect to rescue.

**2.11.6.2** IRATA International requires that a rope access team consists of at least two rope access technicians. However, there are many situations that require more than a two-person rope access team, depending, for example, on the nature of the work; site conditions; competency of the work team; potential rescue scenarios.

**2.11.6.3** A rope access team size of two should only be considered in circumstances where retrieval and rescue by either rope access technician of his/her workmate could be achieved rapidly and unaided by third parties, e.g. where any potential rescue would be a direct lower of the casualty to a safe place. Wherever a potential rescue of the casualty could be other than such a direct lower, a team of three rope access technicians should be regarded as the normal minimum team size, unless other specific arrangements are in place that have been tried and tested by the rope access technicians.

**2.11.6.4** One member of the work team has to be qualified as an IRATA International Level 3 rope access technician and be competent to supervise rope access safety (the *rope access safety supervisor* – see 2.5.2 and 2.6).

**2.11.6.5** Adequate supervision should be provided for each worksite. It may be appropriate to employ more than one Level 3 rope access safety supervisor, depending on the circumstances. Examples are:

- a) the number of rope access technicians working on the site;
- b) complex work situations;
- c) arduous environmental conditions;
- d) when operating on a work site with more than one discrete working area.

**2.11.6.6** Both the Level 3 rope access safety supervisor and their company should ensure before work commences that the rescue procedures are adequate for that situation and that all members of the team have been suitably briefed. Sufficient personnel and resources should be readily available to carry out those procedures, in case the need arises.

**2.11.6.7** Where the work takes place in a particularly hazardous or restricted area, e.g. one which could give rise to poisoning or asphyxiation, the training, abilities, experience, competence and size of the work team should be of a level that is suitable to deal with any emergency arising out of undertaking the work.

**2.11.6.8** Where work is carried out over water, suitable rescue equipment should be provided and measures adopted to arrange for prompt rescue of anyone in danger of drowning.

## 2.11.7 Pre-work checking

**2.11.7.1** If a permit to work is required, this should already have been obtained and checked. Permits to work are an effective method of isolating a hazard before work starts and to ensure that it remains isolated while work is in progress and until everyone is clear of the danger area.

**2.11.7.2** At the start of each day, and as determined by changing site conditions, the work team should review the risks that could affect the safe, efficient and effective outcome of the job. This pre-work briefing should refer to the safety method statement, the risk assessment and the rescue plan already prepared, as well as the rôle of each member of the team.

**2.11.7.3** Any special precautions required should be put into effect (e.g. standby boat alerted; radio check; gas checks; noxious chemicals check; work on or near hot surfaces).

**2.11.7.4** Rope access technicians should carefully examine their own equipment, e.g. harnesses; anchor line devices; device lanyards; connectors, before starting work, to ensure it is in good condition. This is known as *pre-use checking*. The rope access safety supervisor should ensure this occurs. This checking should continue during the course of the job. In addition, there should be a further check by another member of the team, known as *buddy checking*, to ensure, for example, that each other's harness buckles are correctly fastened and adjusted, that device lanyards and anchor lanyards are attached correctly and that connectors are fastened correctly. Buddy checking by team members is good practice and should be continued throughout the day, including:

- a) after the rope access technician has put on his/her harness and assembled his/her equipment;
- b) when the rope access technician has attached to the anchor lines;
- c) at all times when the rope access technician is engaged in rope access manoeuvres.

**2.11.7.5** At the beginning of each working day and at other times as appropriate, e.g. when the anchor lines are relocated during the day, the rope access safety supervisor should carry out a pre-use check to ensure that all the anchors and anchor lines (wire and textile), and the structure or natural feature to which they are attached, are satisfactory. This pre-use check should include any points on the anchor lines where abrasion or other damage, e.g. caused by hot surfaces, could occur. The rope access safety supervisor should also take responsibility for checking anchor lines for length and that, where appropriate, termination stopper knots are in place and secure.

**2.11.7.6** Sometimes, an announcement has to be made to warn other workers that the work is commencing. This is common practice offshore and is often a requirement of the permit to work.

## **2.11.8 Exclusion zones**

### **2.11.8.1 General**

**2.11.8.1.1** Exclusion zones may need to be set up to protect people from falling or to protect people against falling objects from above the area of rope access operations, or anyone below. They may also be required for reasons other than fall protection, e.g. to protect against exposure to: radiation; radio waves such as those emitted by mobile phone antennae; areas of high temperature; chemical pollution. Exclusion zones may be necessary at several levels, e.g. above anchor level; at anchor level; at intermediate levels; at ground level. See **Figure 2.11** for different types of exclusion zones.

**2.11.8.1.2** In some circumstances, the work team may require additional support members for safety reasons, e.g. where there is a need to prevent the public entering an area that could be threatened by falling objects, or to guard against vandals tampering with suspension equipment. The additional persons required to act as sentries need not be trained in rope access work, provided that they are not counted as being a member of the rope access team.

### **2.11.8.2 Protection of third parties**

**2.11.8.2.1** Where required, precautions appropriate to the situation should be provided to prevent equipment or materials falling in such a way that other people might be endangered.

**2.11.8.2.2** Methods of providing precautions include securing all tools to either the rope access technician or to separate lines. Normally, items weighing over eight kilograms should be attached to a separate line, while those below this weight may be secured to the worker (For more information on the use of tools and other work equipment, see **Part 3, Annex M.**) In addition, an exclusion zone should be established beneath the rope access site. Scaffold fans, temporary roof structures or containment nets or sheets could be provided to contain falling materials into safe and confined areas. These should be strong enough to retain any equipment or debris that might fall.



**2.11.8.2.3** Exclusion zones established to protect against falling objects should minimise the risk of being struck by those objects. Where reasonably practicable, the width of the exclusion zone should be at least equal to the height of the work position. Account should be taken of the possibility of material deviating from a straight fall as a result of wind or after bouncing off the structure, natural feature or the ground. People should be discouraged or prevented from entering the exclusion zone or interfering with the rigging by posting suitable notices, providing warning signs, erecting appropriate barriers or installing alarms. Access ways, passageways or doors leading into the zone should be suitably controlled. It should be noted that the control of fire escapes and disabled access points need to be agreed with the building/structure owner or managers.

**2.11.8.2.4** When work is carried out over or near public places, legislation may apply and advice should be obtained from the appropriate local authority.

### **2.11.8.3 Anchor area exclusion zone**

**2.11.8.3.1** An anchor area exclusion zone (also known as a rope access controlled area) should be cordoned off at anchor level with suitable barriers and warning signs. The anchor area exclusion zone should usually be large enough to include anchor points and to provide safe access to the working edge.

**2.11.8.3.2** Only members of the rope access team should be allowed in the anchor area exclusion zone, unless under close supervision.

### **2.11.8.4 Working edge hazard zone**

**2.11.8.4.1** Inside the anchor area exclusion zone, a further exclusion area, often known as the *working edge hazard zone*, may be required. This may be formed by suitable barriers or scaffolding surrounding the working edge and is intended to prevent anyone from reaching the edge of the drop. The working edge hazard zone can be defined as any location within the anchor area exclusion zone where a risk of falling from a height exists.

**2.11.8.4.2** The provision of working edge hazard zone barriers should include areas such as openings where it is necessary to remove handrails or lift pieces of grating to access or exit them. When working on grated deck areas, measures should be taken to prevent items of equipment falling through the grating.

**2.11.8.4.3** No one should be allowed to enter the working edge hazard zone for any purpose, unless they are wearing a harness and helmet and are attached to an anchored safety line.

## **2.11.9 Communication**

**2.11.9.1** An efficient communication system should be established between all rope access technicians and, where necessary, to third parties (e.g. sentries or the control room, if offshore). This should be agreed and set up before work starts and should remain effective for the whole of the time that people are at work.

**2.11.9.2** It is recommended that a radio system or suitable alternative is used for communication purposes, unless the area of work is such that all those involved (including any sentries) are always visible to each other and within audible range. The communication system should allow direct and uninterrupted communication between the rope access safety supervisor and the work team. Potential problems, e.g. noise; radio interference; other work teams' communication systems; weather, should be taken into account. It is preferable for the supervisor to have direct sight of the work team.

**2.11.9.3** Hand or voice signals are liable to be misunderstood. Therefore, any special signals should be agreed and well-rehearsed before work begins. These should include a method, e.g. a sign or a signal, to enable the rope access technician to summon help, should other established methods of communication fail.

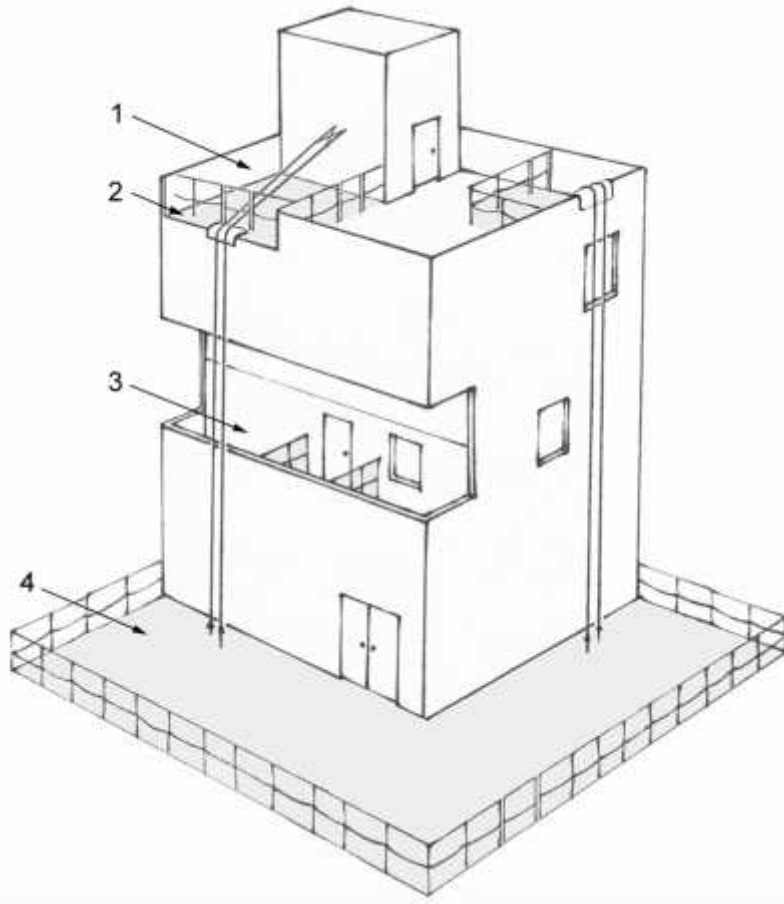

**Key**

- 1 Anchor area exclusion zone
- 2 Working edge hazard zone
- 3 Exclusion zone at intermediate level
- 4 Exclusion zone at bottom level

**Figure 2.11 — Examples of different types of exclusion zone**

**2.11.10 Welfare**

**2.11.10.1** Rope access technicians require adequate facilities where they can rest in the dry, protected from the cold or heat, and where they can obtain fresh water, store any additional clothing and be able to wash. They should also be provided with, or have access to, adequate toilet facilities.

**2.11.10.2** In calculating the length of shifts and rest periods for rope access technicians, consideration should be given to the effects of adverse climatic conditions and/or difficult or very exposed worksites, because these can affect efficiency and tiredness levels. Working in high and exposed places is likely to subject the rope access technician to factors such as wind chill or buffeting by the wind, which can have a significant effect on output at even quite moderate wind speeds. For more information on the effect of wind and height on working times, see **Part 3, Annex O**. Similarly, work in high temperatures can result in heat exhaustion or fainting. Carrying adequate drinking water in these circumstances is essential. Working short shifts minimizes risk to workers in such environments.

**2.11.10.3** The nature of the work equipment to be used should also be taken into account when calculating the length of shifts and rest periods, to prevent unacceptable discomfort or tiredness of the rope access technician, which could affect his/her safety.

### **2.11.11 Emergency procedures**

**2.11.11.1** Even though great care and attention may be given to safe working, accidents can still happen. The survival of an injured or otherwise immobile person often depends on the speed of rescue and the care given to the casualty during and after rescue. Consequently, great importance should be attached to examining the work site at appropriate times, e.g. each day; each change of job; changing environmental conditions, to assess all feasible emergency scenarios and to plan how any resulting rescues would be carried out.

**2.11.11.2** Provisions should be made to ensure that help is provided promptly to any rope access technician who needs it. Rope access technicians should be skilled in appropriate rescue techniques, which should form part of their basic and on-going training.

**2.11.11.3** Rescue equipment should always be present and ready for immediate deployment at the worksite. This equipment should be sufficient to carry out a rescue from any situation on the site. This could be the rope access technician's normal rope access equipment, preferably *rigged for rescue*, e.g. the working line and safety line established with releasable anchors to allow rapid implementation of lowering or hauling in an emergency.

**2.11.11.4** Clear instructions should be given to rope access technicians on the procedures to be taken in site emergencies that could occur unexpectedly, e.g. on nuclear sites, offshore platforms, refineries.

**2.11.11.5** The rope access team should have a planned method for rescue that includes the following:

- a) a clearly defined leader;
- b) adequate equipment;
- c) competent rope access technicians;
- d) practised techniques appropriate to the worksite;
- e) an awareness of the higher loads involved in rescue;
- f) an awareness of suspension intolerance (also known as suspension trauma, suspension syncope and harness induced pathology – see **Part 3, Annex G**), its symptoms and, in particular, how to manage someone suspected of suffering from the condition during the suspension and post-suspension phases of rescue;
- g) the provision of medical aid if required.

**2.11.11.6** There should be a first aid kit at each worksite and someone competent in first aid at all times.

### **2.11.12 Reporting of incidents and accidents**

**2.11.12.1** Reporting accidents and ill health at work is a legal requirement in some countries. Employers should check their own country's legislation.

**2.11.12.2** In addition to any legal requirements, an accurate record of all accidents or near-misses should be kept, including measures to avoid a reoccurrence. All employees should be encouraged to report near-misses.

**2.11.12.3** It is essential that the IRATA International work and safety statistics be completed for all hours worked on rope, accidents, incidents or near misses and returned promptly to IRATA International when requested. The statistics gathered from this information are used in the IRATA International *Work and Safety Analysis* to highlight the industry's safety record, in order to support the use of rope access methods. To assist with IRATA International's aim of continuous improvement of working methods, work and safety statistics are studied for trends so that any lessons may be learned.

### **2.11.13 End of shifts**

At the end of each shift, equipment such as anchor lines, tools and components should be secured or stored safely (see **2.10.7**). While carrying out this procedure, care should be taken to avoid dropping equipment, which could cause injury. Personal equipment should only be removed when the rope access technician is in a safe place. A formal hand-over to the next shift should take place in accordance with local procedures and rules, at which time any relevant information should be passed on.

### **2.11.14 Termination of a job**

At the termination of a job, care should be taken to clear the site properly, with a final inspection of the area before any permit to work is handed back.

### **2.11.15 Expanded techniques**

Rope access is primarily concerned with movement up or down suspended ropes and working from them, and is considered to be primarily a technique for work positioning. However, the techniques and equipment used for this purpose are sometimes expanded to encompass traversing, aid climbing, lead climbing and other forms of access. The resulting system can range from a work positioning system to a fall arrest system, with hybrid systems somewhere in between. For more information, see **Part 3, Annex L**. In addition, non-harness-based height access methods and fall protection, e.g. scaffolding; nets, may sometimes be incorporated in the work plan.



**IRATA International code of practice  
for industrial rope access**

**Part 3: Informative annexes**

**Annex A: Risk assessment**

**September 2013**

The first edition of Annex A was published in January 2010.  
This edition was published in March 2013.

Amendments issued since publication in March 2013

Amd. No	Date	Text affected
1	2013-Sep-01	Front cover: <i>September 2013</i> replaces <i>2013 edition</i> . This page: change of IRATA address and telephone number. Date in footer updated. All the changes are classed as editorial.

Published by:

IRATA International  
First Floor, Unit 3  
Eurogate Business Park  
Ashford  
Kent  
TN24 8XW  
England

Tel: +44 (0)1233 754600

Email: [info@irata.org](mailto:info@irata.org)

Website: [www.irata.org](http://www.irata.org)

Copyright © IRATA International 2013

ISBN: 978-0-9544993-5-8

## **Annex A (informative)**

### **Risk assessment**

#### **Introduction**

Annex A gives advice and other information that could be relevant to users of rope access methods and is one of a number of informative annexes in Part 3 of this code of practice. This informative annex should be read in conjunction with other parts of this code of practice, should not be used in isolation and is not intended to be exhaustive. For further advice, readers should refer to relevant specialist publications.

#### **A.1 General**

**A.1.1** This informative annex is intended to assist rope access companies in their duty to carry out appropriate risk assessments. Risk assessment is also known by other names, e.g. job safety analysis, but for simplicity is referred to throughout this annex as risk assessment.

**A.1.2** A risk assessment is a careful, systematic examination of the hazards in the place of work that could cause harm to people or damage to plant or property. It should be done before the work takes place and before the work and rope access equipment are selected.

##### **A.1.3 For clarification:**

- a hazard is something that has the potential to cause harm to any person, property or animal;
- a risk is the likelihood of that harm actually occurring.

**A.1.4** It is important, when carrying out a risk assessment, to identify the significant hazards, evaluate the level of associated risk and indicate whether existing and/or proposed precautions are suitable to eliminate or minimize the risk.

**A.1.5** Any judgement of the risk should take account of the total number of persons who could be harmed and the severity of that harm, should it occur.

#### **A.2 Carrying out a risk assessment**

**A.2.1** A satisfactory risk assessment can be achieved by carrying out the steps given in **A.2.1.1** to **A.2.1.5**.

##### **A.2.1.1 Identify the hazards in the work place**

- a) The area in which the rope access team is expected to operate should be checked and any hazards that could reasonably be expected to cause harm to the rope access team members should be identified.
- b) Any action that might be taken during the work that could create a hazard with the potential to cause harm to others should be identified. Hazards that could result in major harm or affect several people should be prioritised.
- c) The effect of persons being in the vicinity of the rope access operations who are not part of the rope access team should be assessed with regard to the rope access team members' safety.

##### **A.2.1.2 Identify who could be harmed and how**

Team members and any others who are at risk from each hazard should be identified.

### A.2.1.3 Evaluate the risks and decide on precautions

**A.2.1.3.1** There is more than one way of evaluating the level of risk arising from each hazard. One method uses a risk matrix. **Table A.1**, which is one example of a risk matrix, sets out numerically the likelihood of an incident occurring and the potential severity or consequences of such an incident. The level of risk is a multiplication of the likelihood of an incident occurring and the severity or consequences of it. The risk value and residual risk value after the controls have been put into place are shown in the few examples given in **Table A.3**.

**A.2.1.3.2** The risk matrix is developed by using the simple formula:

***risk = likelihood x severity***

where, in the examples shown in **Table A.1** and **Table A.3**, the ***likelihood*** of an accident occurring has the values:

1. Highly unlikely to occur
2. Possibility remote but has occurred
3. Very infrequently
4. Occasionally
5. Frequently and regularly

and the ***severity*** of the consequences has the values:

1. Minor injury, no time off work
2. Injury resulting in up to three days off work
3. Injury resulting in more than three days off work
4. Major disabling injury (e.g. loss of a limb or an eye)
5. Fatality

**A.2.1.3.3** Multiplying the numbers together (e.g. 2 from the ***likelihood*** list times 4 from the ***severity*** list equals 8) produces a risk rating called a ***risk value*** (see **Table A.1**), which can be categorized as follows:

High (critical risks): 15 to 25;

Medium (significant risks): 8 to 12;

Low (minor risks): 1 to 6.

**A.2.1.3.4** Different actions need to be taken depending on the risk value calculated. Examples of recommendations for actions to be taken in line with the risk value results obtained in **Table A.1** (high, medium or low) are given in **Table A.2**.

**A.2.1.3.5** While the risk matrix method is popular, it can be highly subjective, with the potential for questionable results. Consequently, if a satisfactory risk assessment is to be achieved when using this method, very careful thought has to be given when deciding on the likelihood and severity values.

**A.2.1.3.6** Another method of evaluating the risks, which does not use a risk matrix, asks a series of questions to which the person carrying out the risk assessment provides answers. This method is preferred by the authorities and others as it is arguably less subjective than the risk matrix method.



**Table A.4** provides an example, which is adapted from one provided by the UK Health and Safety Executive (HSE) in their guidance literature.

**A.2.1.3.7** If further precautions are necessary, each hazard should be examined and the following hierarchy of control measures applied, where 1 is the best option and 6 is the option of last resort.

1. Remove the hazard completely.
2. Try a less hazardous option.
3. Prevent access to the hazard.
4. Organize work to reduce exposure to the hazard.
5. Increase the level of information, training and supervision.
6. Use personal protective equipment.

#### **A.2.1.4 Record the findings, implement them and inform team members and others**

**A.2.1.4.1** The findings of the risk assessment and the method to be adopted to eliminate the hazard, control it or reduce it to an acceptable level of risk should be documented. The results of the risk assessment should be communicated to all team members.

**A.2.1.4.2** Team members should understand and comply with the contents of the risk assessment and the measures put in place to reduce the level of risk.

**A.2.1.4.3** Other people in or around the rope access work-site should be informed about any risks that the rope access work could cause them and what precautions are being taken.

**A.2.1.4.4** Significant findings from the risk assessment should be recorded. A record should also be kept if the activity is considered to involve a high level of risk, which includes most rope access activities. The recording of this information may be a statutory requirement.

**A.2.1.4.5** A risk assessment should include:

- a) a statement of the significant hazards identified;
- b) the control measures in place and the extent to which they control the risks, and the options and methods available for workmate rescue (cross-referenced to other documents);
- c) the persons exposed to the risks.

**A.2.1.4.6** The risk assessment should be kept for future reference. It could be useful should these precautions be questioned or if there is any action for civil liability. It is also a reminder to address safety matters and could help to show compliance with the law.

#### **A.2.1.5 Review the risk assessment and revise it when necessary**

The risk assessment should be reviewed at regular intervals and revised when the situation changes (this might be a statutory requirement), e.g.

- a) hazards may change in the same environment over time;
- b) new equipment, procedures or materials may cause new hazards;
- c) changing working environments may introduce significant new hazards of their own. These should be considered in their own right and then whatever is necessary should be done to keep the level of risk low;

d) young or inexperienced workers joining the team may require further actions to be taken.

**A.2.2** Tables A.1 and A.2 are intended to be examples only. Different tables, headings and values might be appropriate for some businesses. Tables A.3 and A.4 are intended only to help the reader think through some of the hazards in their organization and the steps needed to take control of the risks. Neither table is intended to be a generic risk assessment that can be adopted without any thought. Every business is different and so each one should think through for themselves the hazards and controls required.

**Table A.1 — Example of a risk matrix**

		Severity				
		1	2	3	4	5
Likelihood	1	1 LOW	2 LOW	3 LOW	4 LOW	5 LOW
	2	2 LOW	4 LOW	6 LOW	8 MEDIUM	10 MEDIUM
	3	3 LOW	6 LOW	9 MEDIUM	12 MEDIUM	15 HIGH
	4	4 LOW	8 MEDIUM	12 MEDIUM	16 HIGH	20 HIGH
	5	5 LOW	10 MEDIUM	15 HIGH	20 HIGH	25 HIGH

**Key**

**Likelihood**

- 1 Highly unlikely to occur
- 2 Possibility remote but has occurred
- 3 Very infrequently
- 4 Occasionally
- 5 Frequently and regularly

**Severity**

- 1 Minor injury, no time off work
- 2 Injury resulting in up to three days off work
- 3 Injury resulting in more than three days off work
- 4 Major disabling injury (e.g. loss of a limb or an eye)
- 5 Fatality

**Table A.2 — Example of recommendations for action following results in Table A.1**

Risk value result in Table 1	Recommended action
<b>Low (1 to 6)</b>	May be acceptable; however, review the task to see if the risk can be reduced further.
<b>Medium (8 to 12)</b>	Where possible, the task should be redefined to take account of the hazards involved or the risk should be reduced further, prior to task commencement. Appropriate management authorisation after consultation with specialist personnel and an assessment team may be required.
<b>High (15 to 25)</b>	Unacceptable. The task should be redefined or further control measures put in place to reduce the risk. The controls should be re-assessed for adequacy, prior to start of task.

**Table A.3 — Example of a risk assessment using risk value and residual risk numerical values (via a risk matrix)**

NOTE Table A.3 provides a few examples only and is not exhaustive.

<b>ACTIVITY/HAZARD</b> Use procedure as a guide	<b>HAZARD EFFECT</b> Type of injury/damage/environmental impact	<b>PEOPLE AT RISK</b>	<b>RISK VALUE</b> Refer to procedure	<b>CONTROL MEASURES</b> Existing and proposed	<b>RESIDUAL RISK</b>
<i>Here is where you enter the type of hazard that might be encountered while carrying out the task, e.g. Manual handling.</i>	<i>How people at risk might be harmed – this is where you list the <u>actual harm</u> which could result whilst carrying out the task, e.g. injury or back pain from lifting awkward items or weights.</i>	<i>Who might be harmed, e.g. A: Rope access worker; B: the public; C: other trades people.</i>	<i>This means the likelihood of harm and the potential severity of the harm occurring: see Tables A.1 and A.2</i>	<p><i>Once the risks have been assessed, precautions are required to be put in place in order to avoid ‘people at risk’ being harmed and this is where you would list such precautions, e.g.</i></p> <ul style="list-style-type: none"> <li>• <i>Staff to attend mandatory manual handling training session</i></li> <li>• <i>Use ‘safe lifting’ manual handling techniques at all times</i></li> </ul>	<i>See Tables A.1 and A.2</i>
<b>Working at height using rope access or work positioning techniques, fall of personnel</b>	Fatality, serious injury	A	3 x 5 = 15 high	Deployment of twin rope access system as per written procedure ( <i>give reference</i> ) and current IRATA code of practice. Use of certified equipment, competent personnel. Equipment to be stored in secure area when not in use.	1 x 5 = 5 low
<b>Moving or lifting a load</b>	Manual handling, muscular-skeletal injuries	A	3 x 3 = 9 medium	Clear instructions to be given at tool box talks, planned lifts, Personnel to perform warm-up exercises before undertaking any strenuous activity.	3 x 2 = 6 low
<b>Adverse weather</b>	Hypothermia, heat exhaustion	A	3 x 5 = 15 high	Work suspended at discretion of team leader in consultation with authorities. Work not to begin in deteriorating conditions. Wind chill factor to be considered when working in exposed locations. In hot locations ensure fluid intake by personnel is adequate and appropriate eye/skin protection is used.	1 x 5 = 5 low
<b>Potential exposure to radio waves when working on transmitting aerials for mobile phones</b>	General feeling of being unwell: headaches, nausea, sunstroke type symptoms, dehydration, possibly vision impairment	A and C	4 x 3 = 12 medium	Transmission isolation, exclusion zones, use of personal monitor; permit to work system, radio frequency awareness training.	2 x 2 = 4 low

IRATA International code of practice for industrial rope access  
Part 3 of 5: Informative annexes: Annex A

<b>ACTIVITY/HAZARD</b> Use procedure as a guide	<b>HAZARD EFFECT</b> Type of injury/damage/environmental impact	<b>PEOPLE AT RISK</b>	<b>RISK VALUE</b> Refer to procedure	<b>CONTROL MEASURES</b> Existing and proposed	<b>RESIDUAL RISK</b>
<b>Working at height, dropped objects</b>	Impact injuries, damage to equipment	A, B and C	4 x 3 = 12 medium	Work in accordance with the written procedure ( <i>give reference</i> ), tools and equipment secured by lanyard, secured haul sacs to be used, heavy items to be independently secured. Competent personnel. Vulnerable areas to be barriered. Third parties to be kept clear (Permit to work Tannoy announcement).	1 x 3 = low
<b>Use of tools</b>	Dropped objects. Fatality or injury to personnel or damage to asset. Dropped objects relating to equipment or couplant	A, B and C	3 x 5 = 15 high	Set secured on ropes/bridle. Probes kept in tool bag until required. Area below work site barriered, if appropriate. No work above or below work party. Area below work site to be barriered. No work above or below work party. All tools on lanyards.	1 x 5 = 5 low
<b>Non-destructive testing</b>	Control of substances hazardous to health related issues due to couplants, inks, and paints. Potential health related issues	A	4 x 5 = 20 high	Follow manufacturer's material safety sheets and assess accordingly. Correct personal protective equipment. Good hygiene.	1 x 5 = 5 low
<b>Grit blasting, spraying, painting</b>	Cutting through rope causing fall, serious injury/fatality	A	4 x 5 = 20 high	Personnel trained and competent in using this technique when suspended. Work instructions to be adhered to at all times. Back up hard line attachment for personnel out of range of blasting nozzle. Use of rope protectors on exposed locations. Standby personnel to perform emergency shut downs and test before use. Recovery system to be in place.	1 x 5 = 5 low
<b>Grit blasting, spraying, painting</b>	Technician blasts himself, grit injection, paint injection, severe abrasions, personal injury	A	4 x 3 = 12 medium	Personnel trained and competent in using this technique when suspended. Dead man's lever to be tested operational before blasting commences. Recovery system in place. Suitable personal protective equipment to be worn. Care to be taken that personal protective equipment does not impair operation of rope access equipment.	1 x 3 = 3 low

**Table A.4 — Example of a risk assessment that does not use a risk matrix**

Company name: TVW Contract Bricklayers			Date of risk assessment: 06 March 2010			
What are the hazards?	Who might be harmed and how?	What are you already doing?	What further action is necessary?	Action by whom?	Action by when?	Date carried out
Falling from a height	Serious injury or even fatal injury could occur if a worker falls.	<ul style="list-style-type: none"> <li>• Agree scaffolding requirements at contract stage, including appropriate load rating and provision of loading bays.</li> <li>• Bricklayers' supervisor to check with site manager that the correct scaffold is provided and inspected.</li> <li>• Workers instructed not to interfere with or misuse scaffold. Supervisor to keep an eye out for problems.</li> <li>• Ladders in good condition, adequately secured (lashed) and placed on a firm surface.</li> <li>• Band stands with handrails to be used for work on internal walls.</li> <li>• Workers trained to erect bandstands.</li> </ul>	<ul style="list-style-type: none"> <li>• Scaffold requirements agreed, including loading bays and appropriate load rating.</li> </ul>	DT	20.03.10	19.03.10
			<ul style="list-style-type: none"> <li>• Supervisor to speak regularly to site manager to arrange scaffold alterations and ensure that weekly inspections have been carried out.</li> </ul>	CR	From 01.05.10	
Collapse of scaffold	All operatives on scaffold may incur crush injuries, or worse, if the scaffold collapses on top of them.	<ul style="list-style-type: none"> <li>• Agree scaffolding requirements at contract stage, including appropriate load rating and provision of loading bays.</li> <li>• Bricklayers' supervisor to check with the site manager that the correct scaffold is provided and inspected.</li> </ul>	<ul style="list-style-type: none"> <li>• Supervisor to keep a check to make sure that the scaffold is not overloaded with materials.</li> </ul>	CR	From 01.05.10	
Falling objects hitting head or body, including feet	Serious head and other injuries to workers, others on site and members of the public.	<ul style="list-style-type: none"> <li>• Brick guards kept in position on scaffold lifts.</li> <li>• Waste materials removed from scaffolding and placed in skip.</li> <li>• Safety helmets and protective footwear (with steel toecaps and mid-soles) supplied and worn at all times</li> </ul>	<ul style="list-style-type: none"> <li>• Supervisor to monitor use of safety hats and protective footwear.</li> </ul>	CR	From 01.05.10	



**IRATA International code of practice  
for industrial rope access**

**Part 3: Informative annexes**

**Annex B: Safety method statements**

**September 2013**

The first edition of Annex B was published in January 2010.  
This edition was published in March 2013.

Amendments issued since publication in March 2013

Amd. No	Date	Text affected
1	2013-Sep-01	Front cover: <i>September 2013</i> replaces <i>2013 edition</i> . This page: change of IRATA address and telephone number. Date in footer updated. All the changes are classed as editorial.

Published by:

IRATA International  
First Floor, Unit 3  
Eurogate Business Park  
Ashford  
Kent  
TN24 8XW  
England

Tel: +44 (0)1233 754600

Email: [info@irata.org](mailto:info@irata.org)

Website: [www.irata.org](http://www.irata.org)

Copyright © IRATA International 2013

ISBN: 978-0-9544993-5-8

## **Annex B (informative)**

### **Safety method statements**

#### **Introduction**

Annex B gives advice and other information that could be relevant to users of rope access methods and is one of a number of informative annexes in Part 3 of this code of practice. This informative annex should be read in conjunction with other parts of this code of practice, should not be used in isolation and is not intended to be exhaustive. For further advice, readers should refer to relevant specialist publications.

#### **B.1 What is a safety method statement?**

A safety method statement, which is sometimes known by other names, is a document that provides the sequence of procedures necessary for the safe execution of a task. It is prepared in conjunction with the results of a hazard identification and risk assessment. The hazard identification and risk assessment highlight any significant hazards and the control measures required to prevent injury or ill health while carrying out the task. The safety method statement details the control measures that are being or have been introduced to ensure the safety of anyone who is affected by the task or process.

#### **B.2 Information to be provided in a safety method statement**

**B.2.1** There should be title and header information, which should include:

- a) document title, e.g. *Safety method statement*;
- b) company details, e.g. name; address; telephone numbers; email address;
- c) document author; health and safety contact person;
- d) document traceability details, e.g. number; issue date; revision date; revision number;
- e) site address;
- f) site contact details, including emergency telephone numbers;
- g) start date and completion date;
- h) a brief description of the works, task or process.

**B.2.2** Detailed relevant information should be provided, such as:

- a) background, e.g. comparison with previous similar work, and preparation, e.g. the need for and use of any specialist equipment;
- b) in operations involving more than one company, clarification and management approval at the planning stage of a single work procedure;
- c) how any relevant site specific/client procedures are to be conformed to;
- d) the sequence of events in carrying out the task, including hazard identification and risk control measures, in line with the company's safe working procedures;
- e) the appropriate personal protective equipment (PPE) to be used;



- f) personnel information, including: qualifications, levels of competency, training requirements and team structure, names of the people who are responsible for co-ordinating and controlling safety arrangements;
- g) permits to work;
- h) isolation of machinery and services;
- i) arrangement for any temporary services required, e.g. electricity;
- j) special equipment, plant and machinery requirements, including certification where applicable;
- k) arrangements for the control of site transport;
- l) worksite access and egress requirements;
- m) arrangements for safeguarding personnel, third parties, the general public and the exclusion of third parties from the work area;
- n) details of areas outside the site boundaries that may need control during critical aspects of work, e.g. road closures;
- o) the method by which clear communications between team members and any involved third-party personnel, e.g. safety boat, are established;
- p) the method by which third parties, e.g. site authorities; principal contractor, are made fully aware of the rope access team's activities;
- q) material handling rules;
- r) any environmental or quality procedures that have to be addressed during the task, e.g. control of substances hazardous to health; disposal of waste;
- s) limiting weather conditions, e.g. rain; wind; temperature;
- t) a rescue plan and other emergency considerations, e.g. evacuation; procedures in case of fire.
- u) welfare and first aid.
- v) the frequency of on-going briefing, e.g. toolbox talks (also known as tailgate talks);

### **B.3 Important advice**

**B.3.1** It is essential that the safety method statement is shown to, and fully understood by, all the members of the team, and that it is made freely available to them for the duration of the work.

**B.3.2** Should the scope change during the work operations from that covered in the safety method statement, the appropriate documents should be amended to highlight the changes. The amended documents should first receive any necessary management approval and then they should be shown to all members of the team, who should understand them before the new work is carried out.



**IRATA International code of practice  
for industrial rope access**

**Part 3: Informative annexes**

**Annex C: List of standards referred to within  
the code of practice**

**September 2013**

The first edition of Annex C was published in January 2010.  
This edition was published in March 2013.

Amendments issued since publication in March 2013

Amd. No	Date	Text affected
1	2013-Sep-01	Front cover: <i>September 2013</i> replaces <i>2013 edition</i> . This page: change of IRATA address and telephone number. Clause C.1: additional sentence added to first paragraph and titles updated to EN 341, EN 354 and EN 795. Date in footer updated. All the changes are classed as editorial.

Published by:

IRATA International  
First Floor, Unit 3  
Eurogate Business Park  
Ashford  
Kent  
TN24 8XW  
England

Tel: +44 (0)1233 754600

[www.irata.org](http://www.irata.org)

Copyright © IRATA International 2013

ISBN: 978-0-9544993-5-8

## **Annex C (informative)**

### **List of standards referred to within the code of practice**

#### **Introduction**

Annex C gives advice and other information that could be relevant to users of rope access methods and is one of a number of informative annexes in Part 3 of this code of practice. This informative annex should be read in conjunction with other parts of this code of practice, should not be used in isolation and is not intended to be exhaustive. For further advice, readers should refer to relevant specialist publications.

#### **C.1 List of standards**

For dated references, only the edition cited applies. For undated references, the latest edition of the referenced document (including any amendments) applies. Readers should ensure they have the latest version (including any amendments).

ANSI/ASSE Z359.1, *Safety Requirements for Personal Fall Arrest Systems, Subsystems and Components*

ANSI/ASSE Z359.12, *Connecting Components for Personal Fall Arrest Systems*

BS 7883, *Code of practice for the design, selection, installation, use and maintenance of anchor devices conforming to BS EN 795*

CI 1801, *Low Stretch and Static Kernmantle Life Safety Rope*

CI 2005, *Inspection of Kernmantle Ropes For Life Safety Applications*

EN 341, *Personal fall protection equipment — Descender devices for rescue*

EN 354, *Personal fall protection equipment — Lanyards*

EN 361, *Personal protective equipment against falls from a height — Full body harnesses*

EN 362, *Personal protective equipment against falls from a height — Connectors*

EN 397, *Specification for industrial safety helmets*

EN 795, *Personal fall protection equipment — Anchor devices*

EN 813, *Personal protective equipment for the prevention of falls from a height — Sit harnesses*

EN 892, *Mountaineering equipment — Dynamic mountaineering ropes — Safety requirements and test methods*

EN 1891: 1998, *Personal protective equipment for the prevention of falls from a height — Low stretch kernmantel ropes*

EN 12278, *Mountaineering equipment — Pulleys — Safety requirements and test methods*

EN 12492, *Mountaineering equipment — Helmets for mountaineers — Safety requirements and test methods*

EN 12841, *Personal fall protection equipment — Rope access systems — Rope adjustment devices*

EN 14052, *High performance industrial helmets*

ISO 10333-1, *Personal fall arrest systems — Part 1: Full-body harnesses*

ISO 10333-2, *Personal fall arrest systems — Part 2: Lanyards and energy absorbers*

ISO 10333-5, *Personal fall arrest systems — Part 5: Connectors with self-closing and self-locking gates*

ISO 22159, *Personal equipment for protection against falls — Descending devices*

UIAA-101, *Mountaineering and Climbing Equipment — Dynamic ropes*

UIAA-127, *Mountaineering and Climbing Equipment — Pulleys*

## **C.2 Explanation of abbreviations**

The following is an explanation of the abbreviations used in **C.1**:

ANSI: American National Standards Institute;

ASSE: American Society of Safety Engineers;

BS: British Standard;

CI: Cordage Institute (USA);

EN: European Standard;

ISO: International Standards Organization;

UIAA: International Mountaineering and Climbing Federation.



**IRATA International code of practice  
for industrial rope access**

**Part 3: Informative annexes**

**Annex D: Harness comfort and  
adjustability test**

**September 2013**

The first edition of Annex D was published in January 2010.  
This edition was published in March 2013.

Amendments issued since publication in March 2013

Amd. No	Date	Text affected
1	2013-Sep-01	Front cover: <i>September 2013</i> replaces <i>2013 edition</i> . This page: change of IRATA address and telephone number. Date in footer updated. All the changes are classed as editorial.

Published by:

IRATA International  
First Floor, Unit 3  
Eurogate Business Park  
Ashford  
Kent  
TN24 8XW  
England

Tel: +44 (0)1233 754600

Email: [info@irata.org](mailto:info@irata.org)

Website: [www.irata.org](http://www.irata.org)

Copyright © IRATA International 2013

ISBN: 978-0-9544993-5-8

## **Annex D (informative)**

### **Harness comfort and adjustability test**

#### **Introduction**

Annex D gives advice and other information that could be relevant to users of rope access methods and is one of a number of informative annexes in Part 3 of this code of practice. This informative annex should be read in conjunction with other parts of this code of practice, should not be used in isolation and is not intended to be exhaustive. For further advice, readers should refer to relevant specialist publications.

#### **D.1 General**

It is recommended that, before first use, rope access technicians carry out a test on their harness in a safe environment to ensure:

- a) the harness provides an acceptable level of comfort while the rope access technician is suspended, e.g. while carrying out rope access work or following a fall;
- b) there is no restriction of movement sufficient to cause difficulties while working;
- c) there is sufficient adjustment, e.g. to cater for different amounts of clothing worn.

This annex gives a test procedure for assessing the criteria listed above. The test is suitable for sit harnesses and full body harnesses. It should not be used for belts without sub-pelvic support or for chest harnesses.

#### **D.2 Safety precautions**

**D.2.1** Part of the test procedure involves the rope access technician being suspended clear of the ground while wearing the harness. The suspension test should be carried out in a safe place, under the direct supervision of another person. There should be someone on site who is competent in first aid for dealing with emergencies involving persons working at a height. This could be the person supervising or another person. The test should be arranged so that the rope access technician is suspended with only a small clearance between the feet and the ground, e.g. 100 mm. Some type of support should be provided, e.g. a block of wood, of a height slightly greater than the clearance between the rope access technician's feet and the ground, so that he/she is able put their feet on it to support their weight if the harness proves to be too painful, or any other discomfort is experienced.

**D.2.2** The suspension test should be stopped immediately if the rope access technician experiences any unacceptable pain at any time during the test procedure. The test should also be stopped immediately if the rope access technician experiences any of the following:

- faintness or dizziness;
- breathlessness;
- sweating or hot flushes;
- nausea;
- loss or greying of vision;
- an abnormal increase in pulse rate;
- an abnormal decrease in pulse rate.



**D.2.3** The test procedure calls for the suspension test to be carried out for each of the harness attachment points that could be used in practice. Each test should have a maximum duration of 4 min, and the rope access technician should take a break of at least 5 min between tests. While in suspension, he/she should move their legs from time to time to maintain circulation and, for the same reason, during the breaks they should exercise their legs periodically, for example, by walking about.

### **D.3 Procedure**

**D.3.1** The rope access technician should be supervised throughout the procedure. The procedure detailed in D.3.2 to D.3.7 should be carried out for each of the harness attachment points designated by the manufacturer that might be used by the rope access technician. If the harness has attachment points that are intended to be used in pairs, these should always be used in pairs.

**D.3.2** The rope access technician should don the harness in accordance with the manufacturer's instructions and adjust it to ensure a snug fit.

**D.3.3** Following the manufacturer's instructions for connection to the harness attachment point(s), the rope access technician should be suspended by means of a suitable system, e.g. a winch or a pulley system and appropriate personal fall protection equipment, such that he/she can be suspended with their feet just clear of the ground.

**D.3.4** The duration of the test should be timed with a stop-watch. Taking into account the safety precautions given in D.2, the test should be stopped after a minimum of 3 min 45 s and a maximum of 4 min, and the rope access technician released from suspension.

**D.3.5** Adjustment of the harness while the rope access technician is in suspension may be made at any time during the test. If the rope access technician has to step down to the floor or on to the raised support for readjustment of the harness, the timing of the test should start again from the beginning, once the readjustment is completed.

**D.3.6** During the test, while the rope access technician's feet are off the ground, the harness should be examined by the supervisor to determine points a) and b) below and the rope access technician asked to comment on points c) and d) whether:

- a) any metal fitting is in contact with the groin, the inside of the thighs, the armpits or the small of the back;
- b) any part of the harness is exerting direct pressure on the genitals, head or neck;
- c) there is any loss of feeling (numbness) or tingling ("pins and needles"), either of which is unacceptable to the rope access technician, in any part of the body;
- d) there is any restriction of normal breathing.

In addition to the safety precautions detailed in **D.2**, if the harness is in contact or causing pressure as detailed in item a) or b), or if the rope access technician experiences any of the symptoms listed in items c) and d), the test should be stopped immediately.

**D.3.7** During the test, while the feet are clear of the ground, the rope access technician should carry out the following movements to determine whether the harness allows adequate freedom of movement:

- a) hold the left foot with the right hand, then release;
- b) hold the right foot with the left hand, then release;
- c) hold both hands together at full stretch above the head, then release;
- d) hold both hands together behind the waist and then release.

**D.3.8** After the suspension test is completed, and with the rope access technician standing on the ground, the amount of adjustment in each adjustable part of the harness, e.g. the length of strap ends, including any length required for locking the adjusters, should be checked to ensure there is sufficient adjustment to allow for less or additional clothing to be worn for the expected conditions of work, for example, in hot or cold weather.

#### **D.4 Evaluation of results**

The harness can be judged as suitable if all the following conditions are met:

- a) it was not necessary to stop the test for any of the reasons given in **D.2** or **D.3.6** and the rope access technician agreed that the comfort level experienced during the tests was acceptable;
- b) the rope access technician was able to carry out the movements given in **D.3.7** a) to d) with relative ease and he/she agreed that there was adequate freedom of movement to allow him/her to carry out their work.
- c) the harness was considered to have sufficient adjustment for the expected conditions of work, when assessed in accordance with **D.3.8**.

It is recommended that a record of the test and evaluation of the results is completed and kept for future referral.



**IRATA International code of practice  
for industrial rope access**

**Part 3: Informative annexes**

**Annex E: Other types of lanyard**

**December 2013**

The first edition of Annex E was published in October 2011.  
This edition was published in March 2013.

Amendments issued since publication since March 2013

Amd. No	Date	Text affected
1	2013-Sep-01	Front cover: <i>September 2013</i> replaces <i>2013 edition</i> . This page: change of IRATA address and telephone number. Date in footer updated. All the changes are classed as editorial.
2	2013-Dec-01	Front cover: <i>December 2013</i> replaces <i>September 2013</i> . Date in footer updated. E.3.2: Words ( <i>safety back-up excluded</i> ) are deleted due to change of drawing in Figure E.7. Drawings in Figures E.6 and E.7 changed.

Published by:

IRATA International  
First Floor, Unit 3  
Eurogate Business Park  
Ashford  
Kent  
TN24 8XW  
England

Tel: +44 (0)1233 754600

Email: [info@irata.org](mailto:info@irata.org)

Website: [www.irata.org](http://www.irata.org)

Copyright © IRATA International 2013

ISBN: 978-0-9544993-5-8

## Annex E (informative) Other types of lanyard

### Introduction

Annex E gives advice and other information that could be relevant to users of rope access methods and is one of a number of informative annexes in Part 3 of this code of practice. This informative annex should be read in conjunction with other parts of this code of practice, should not be used in isolation and is not intended to be exhaustive. For further advice, readers should refer to relevant specialist publications.

### E.1 General

**E.1.1** It is recommended that Part 2, 2.7.1 and 2.7.8 are read and understood before reading this informative annex. The user should also read and understand the product information supplied by the manufacturer.

**E.1.2** There are many types of lanyard and often these lanyards can be used for different applications within a personal fall protection system, e.g. in a rope access system, a device lanyard can sometimes be used as an anchor lanyard. Sometimes, lanyards may be suitable for use in more than one personal fall protection system. For example, some lanyards designed for use in a fall arrest system may be used in a rope access system, a work positioning system or a work restraint (travel restriction) system. However, as explained in **Part 2, 2.7.1.6** and **2.7.1.7**, the converse is not true: equipment specifically for use in a work restraint system should not be used in a work positioning or fall arrest system and lanyards specifically for use in a work positioning system should not be used in a fall arrest system. Lanyards specifically for rope access are covered in **Part 2, 2.7.8**.

### E.2 Fall arrest lanyards

#### E.2.1 General

**E.2.1.1** Fall arrest systems (see **Part 2, 2.7.1.5**) should incorporate an energy dissipating element, component or feature to keep the impact load (more accurately, the deceleration) experienced by the user in a fall to an acceptable level. This varies from 4 kN to 8 kN, depending on the region, e.g. in the European Union it is currently a maximum of 6 kN, in Canada it varies between 4 kN and 6 kN, while in the USA, it is generally 6 kN but in some cases is allowed to reach 8 kN for a few milliseconds (ms). (This brief excursion to 8 kN is considered to be inconsequential.) The impact loads are kept below these maximums typically by the use of an energy absorber either integrated with or attached to the fall arrest lanyard that connects the user directly or indirectly to the structure or natural feature.

**E.2.1.2** Fall arrest lanyards should be known to have minimum static strengths in accordance with local legislation or good practice. Examples of minimum static strengths for fall arrest lanyards made from man-made fibres are 22 kN in Europe and 5,000 lbs/22.7 kN in the USA, and for fall arrest lanyards made from steel wire: 15 kN in Europe, 15 kN in Canada but 5,000 lbs/22.7 kN in the USA.

#### E.2.2 Energy-absorbing fall arrest lanyards

**E.2.2.1** As explained in **E.2.1.1**, energy-absorbing fall arrest lanyards are intended to ensure that any impact load experienced by a rope access technician who falls does not exceed an acceptable maximum. See **Figure E.1** and **Figure E.2** for two examples of energy-absorbing fall arrest lanyards. Appropriate energy-absorbing fall arrest lanyards can be used as device lanyards fitted between the user and a fall arrest or back-up device, and as anchor lanyards, but see **E.2.2.2**. They could also be fitted between an anchor and an anchor line, (working line, safety line or both). However, this is unusual, has certain problems, and is not covered in this annex.

**E.2.2.2** As well as having to keep the impact load in a fall to an acceptable level, energy-absorbing fall arrest lanyards conforming to known standards have a requirement not to deploy more

than a few millimetres under a certain minimum load: this is typically 2 kN. To ensure correct functioning of the energy absorber, should it be called upon to arrest a fall, it is important that this load is not exceeded. A user of say 100 kg mass including equipment carried could easily achieve a 2 kN load on the energy-absorbing fall arrest lanyard if it were used for support. Unless an energy-absorbing fall arrest lanyard is specifically designed to support a user, such use should be avoided.

**E.2.2.3** Energy absorbers, particularly those used to support the user, should always be checked before each use and continually while being used to ensure they have not been partially or fully deployed. If there are any signs of deployment, the energy-absorbing fall arrest lanyard should be taken out of service.

**E.2.2.4** In all cases where energy-absorbing fall arrest lanyards are used, careful attention should be given to the additional clearance distance required due to the extension of the energy absorber during deployment, should a fall occur.

**E.2.2.5** It is important to ensure that energy-absorbing fall arrest lanyards are appropriate for the mass of the user including any equipment carried. This can be confirmed by checking the marking on the energy-absorbing fall arrest lanyard or by reading the information supplied by the manufacturer. This advice applies to rope access technicians with a low mass as well as those with a high mass. If there is any doubt about the energy-absorbing fall arrest lanyard being appropriate, the manufacturer or his authorized representative should be contacted and written confirmation obtained.

**E.2.2.6** Energy-absorbing fall arrest lanyards should not be extended beyond the maximum length specified by the manufacturer, e.g. by linking two energy-absorbing fall arrest lanyards or other lanyards end to end. This is because the potential free fall distance is increased, with an increased risk of hitting the ground, structure or natural feature and, in addition, the loads on the user in a fall could rise to an unacceptable level.

**E.2.2.7** Two (or more) energy-absorbing fall arrest lanyards should not be used in parallel, i.e. side by side. This is because in a fall the load might be shared by both (or all) the energy absorbers. This is likely to cause them not to function as intended and for there to be an increase in the loads experienced, which could result in a serious injury. Also see **E.2.3.2**.

**E.2.2.8** For reasons similar to those given in **E.2.2.6**, it is not recommended to connect an energy-absorbing fall arrest lanyard to the end of the retractable lanyard of a retractable fall arrest device, unless this is permitted by the manufacturers.

### **E.2.3 Twin-tailed energy-absorbing fall arrest lanyards**

**E.2.3.1** When there is a need to climb up, down, diagonally or horizontally on a structure such as a tower or mast, a method commonly employed is the use of twin-tailed (sometimes known as twin-legged) fall arrest lanyards. Twin-tailed fall arrest lanyards should employ a single energy dissipating feature, i.e. an energy absorber, to which at one end two lanyards are incorporated. These are the tails (or legs). The other end of the energy absorber is intended for attachment to a fall arrest harness. See **Figure E.2** for an example of a twin-tailed energy-absorbing fall arrest lanyard. Each tail end is fitted with a suitable connector, which, in use, is connected to the structure alternately as progress is made, in such a way that the length of any potential fall is minimised. Should a fall occur, the load is taken by a single energy absorber, which should perform as intended and keep the impact load to an acceptable level.

**E.2.3.2** A twin-tailed energy-absorbing fall arrest lanyard should not be confused with two single energy-absorbing fall arrest lanyards, where each is equipped with its own energy absorber. The use of two such single lanyards is not recommended as there is an inherent problem with this method. In the very predictable situation that both lanyards are connected to the structure at the same time and a fall occurs, the impact load on the user is likely to be much higher than the intended maximum impact load of the energy absorber. This is because the load has been shared by two energy absorbers, which have not been able to function as intended. This could result in a serious injury.

**E.2.3.3** There are also potential safety issues that apply to some designs of twin-tailed energy-absorbing fall arrest lanyards. In November 2004, a worker received fatal injuries as a result of falling

from a transmission tower. The worker was using a twin-tailed energy-absorbing fall arrest lanyard and the lanyard failed during the fall arrest phase. The ensuing investigation highlighted important factors that are essential in the design of twin-tailed energy-absorbing fall arrest lanyards. These are described in **E.2.3.3.1** to **E.2.3.3.3**.

**E.2.3.3.1** The attachment point between the energy absorber and lanyard tails sometimes consists of webbing that is stitched back onto itself to form a connecting loop. When a fall arrest load is applied to the lanyard assembly, such that the load is in line with the energy absorber body, this connecting loop should transfer the load without failing. This type of loading is illustrated in **Figure E.3**. However, in some fall arrest situations, a side load can be applied to the loop, see **Figure E.4**. In a poorly designed product, this load will tend to rip apart the stitching on the loop.

**E.2.3.3.2** A side load can be applied to the connecting loop if the user falls from a structure when the twin-tailed energy-absorbing fall arrest lanyard is used in either of the following two ways:

- a) both tails of the twin-tailed energy-absorbing fall arrest lanyard are attached to different locations on the structure, e.g. the twin-tailed energy-absorbing fall arrest lanyard is used to move along a structure horizontally and the user falls with both lanyard tails attached to the structure. The worst case is when the tails are at the maximum usable horizontal distance between the ends of the lanyard tails;
- b) one tail is attached to a side connection point on the user's fall arrest harness or to the harness webbing and one tail is attached to an anchorage point on the structure with the tail positioned between the user's legs when the user falls. (This is bad practice: see **E.1.3.6**.) **E.2.3.3.3**. It is also conceivable that side loading may be applied to the connecting loop in the event of a fall when the user is moving vertically up and down, horizontally or diagonally on a structure.

**E.2.3.4** It is essential that the design of a twin-tailed energy-absorbing fall arrest lanyard is such that no matter which direction the load in a fall is applied to the point where the lanyard tails are attached to the energy absorber, there is no catastrophic failure of any part of the twin-tailed fall arrest lanyard. Before using twin-tailed energy-absorbing fall arrest lanyards, rope access technicians are strongly advised to check the configurations permitted by the manufacturer. Conformance to an appropriate standard is recommended. An example of an appropriate standard for twin-tailed energy-absorbing fall arrest lanyards is British Standard BS 8513:2009, Personal fall protection equipment – Twin-legged energy-absorbing lanyards – Specification.

**E.2.3.5** If there are any doubts about the design safety of a twin-tailed energy-absorbing fall arrest lanyard, verification that the product has been successfully tested should be sought from the manufacturer or his authorised representative. In this case, if written verification cannot be supplied, it is recommended that the twin-tailed energy-absorbing fall arrest lanyard is not used.

**E.2.3.6** An unused lanyard tail should not be attached back to the harness or clothing (e.g. to keep it out of the way) except to specifically designed breakaway attachment points intended to fail at low loads. These are sometimes referred to as parking points.

**E.2.3.7** Only the free end of the energy absorber, i.e. the end of energy absorber at which the tails are not attached, should be attached to the harness attachment point.

**E.2.3.8** Twin-tailed energy-absorbing fall arrest lanyards should not be used in situations where they could be stressed over an edge in the event of a fall.

**E.2.3.9** The shortest twin-tailed energy-absorbing fall arrest lanyard suitable for the task should be selected and, during use, the amount of slack in it should always be kept to a minimum.

**E.2.3.10** Account should be taken of the minimum clearance distance required to prevent a collision with the ground or structure, should a fall from a height occur.

### **E.3 Work positioning lanyards**

**E.3.1** Work positioning lanyards are used in a work positioning system to support the user, either partially or fully. For more information on work positioning systems, see **Part 2, 2.7.1.5** and Annex L. (Lanyards used in rope access are covered in **Part 2, 2.7.8**).

**E.3.2** Designs of work positioning lanyards differ depending on the work positioning method employed, see **Annex L, Figure E.5** shows examples of adjustable work positioning lanyards (sometimes called pole straps) for partial support in a work positioning method which uses a work positioning lanyard passed around a structure and connected to the harness. This connection is typically to two side waist attachment points on the harness or to a central attachment point at approximately waist level. **Figure E.6** shows one of these adjustable work positioning lanyards in use. **Figure E.7** shows an example of a method of work positioning used on relatively steep or slippery sloping surfaces, e.g. a roof or a steep concrete or grassy banking. (Rope access technicians are recommended to use rope access equipment, procedures and techniques.)

**E.3.3** Work positioning lanyards may be made from textiles, e.g. webbing or rope, or metal, e.g. wire rope. They may be of a fixed length or may be equipped with an adjustment element. An adjustable work positioning lanyard may be a proprietary system or not, e.g. it could consist of an anchor line and an appropriate anchor line device.

**E.3.4** Adjustable work positioning lanyards offer an alternative to fixed-length anchor lanyards in rope access (see **Part 2, 2.7.8**). Being able to set a precise length of lanyard can assist in several manoeuvres and also reduce potential fall distances. Adjustment elements on work positioning lanyards should not be capable of inadvertent adjustment because this could lead to an unintended lengthening of the work positioning lanyard and an unplanned potential fall situation. Adjustment elements should not be capable of being detached from the work positioning lanyard inadvertently. To protect against this, if the adjustment element can be detached from the work positioning lanyard, it should be such that it can only be detached and attached by at least two consecutive deliberate manual actions.

**E.3.5** Where work positioning lanyards could be vulnerable to wear, e.g. where they are often in contact with the structure while under load, or damage, e.g. by powered tools, they should be of a heavier duty than normal lanyards and/or be protected from wear or damage, e.g. by a protective sleeve or by the use of lanyards made from steel wire.

**E.3.6** To allow for foreseeable misuse, it is recommended that work positioning lanyards have at least the same static strength as lanyards used for fall arrest.

**E.3.7** Work positioning lanyards should not be difficult to adjust and ideally this should be possible with one hand.

### **E.4 Restraint lanyards**

**E.4.1** Restraint lanyards are used to restrict a user's broadly horizontal travel so that he/she is physically prevented from reaching zones where there is a risk of a fall from a height, e.g. a fall over an edge (see **Part 1, 1.3** for the definition of work restraint). For information on restraint systems, see **Part 2, 2.7.1.5** and **Annex L, L.2**.

**E.4.2** The length of a restraint lanyard should be such that, when connected to the selected anchor point, it is long enough to allow the user to carry out the intended work but short enough to prevent a situation where a fall might have to be arrested. The restriction of travel should be determined, e.g. by measuring the distance from the anchor point to the closest point at which there could be a risk of a fall from a height. The length of the restraint lanyard should be limited to less than that distance when measured from the anchor point to the attachment point on the user's body-holding device, which may be a simple belt or a harness.

**E.4.3** The range of broadly horizontal travel can sometimes be extended by the use of a horizontal anchor line to which the restraint lanyard is attached, e.g. by an appropriate connector. However, great care should be taken when using horizontal anchor lines to ensure any sag in the line,



e.g. when under the load of a person, would not allow the user to reach zones where there could be a risk of a fall from a height.

**E.4.4** A lanyard or anchor line intended solely for restraint should not be used for fall arrest purposes, nor should it be used to support the weight of a person, either partially or fully, e.g. as in a work positioning system. However, sometimes users do choose to use restraint lanyards for support, e.g. on a sloping surface where normally support from an anchor line or lanyard is not needed but where at certain times it would aid carrying out the task in hand. When using a restraint lanyard in such a way, which, it is stressed, is not recommended, users should be fully aware of the consequences of a slip or equipment failure and should consider employing a safety back-up system such as that used in a work positioning or rope access system.

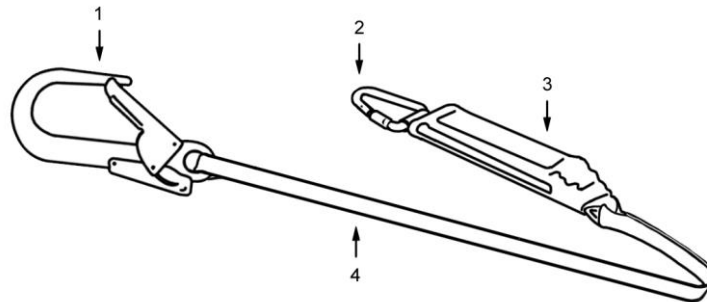

**Key**

- 1 Connector for attachment to structure
- 2 Connector for attachment to harness fall arrest attachment point
- 3 Energy absorber
- 4 Lanyard

**Figure E.1 — Example of an energy-absorbing fall arrest lanyard**

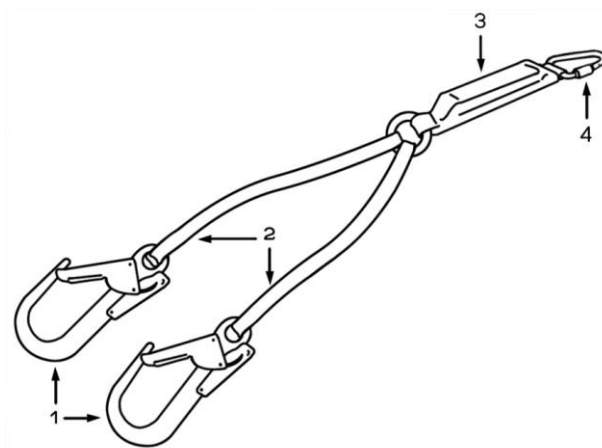

**Key**

- 1 Connectors for attachment to structure
- 2 Lanyard tails (or legs)
- 3 Energy absorber
- 4 Connector for attachment to harness fall arrest attachment point

**Figure E.2 — Example of a twin-tailed energy-absorbing fall arrest lanyard**



**Key**

L Load

**Figure E.3 — Twin-tailed energy-absorbing fall arrest lanyard loaded in line with the energy absorber**

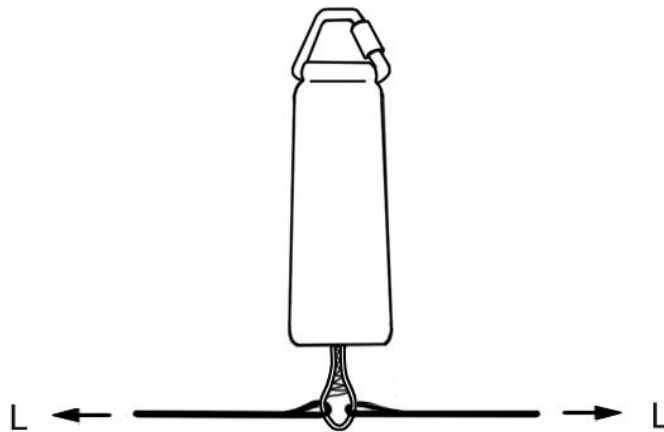

**Key**

L Load

**Figure E.4 — Twin-tailed energy-absorbing fall arrest lanyard loaded sideways, showing potential for stitching failure**

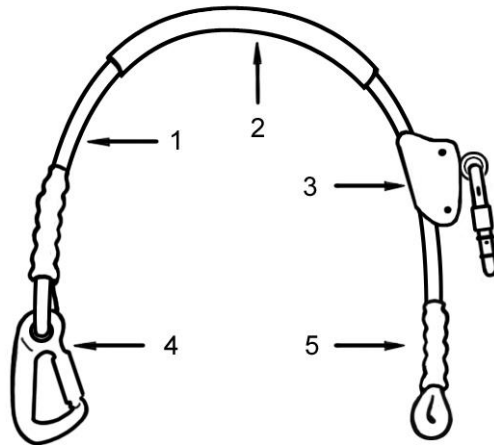

a) Example of an adjustable work positioning lanyard made from rope

**Key**

- 1 Rope lanyard
- 2 Protective sleeve
- 3 Adjustment device
- 4 Connector
- 5 End stop

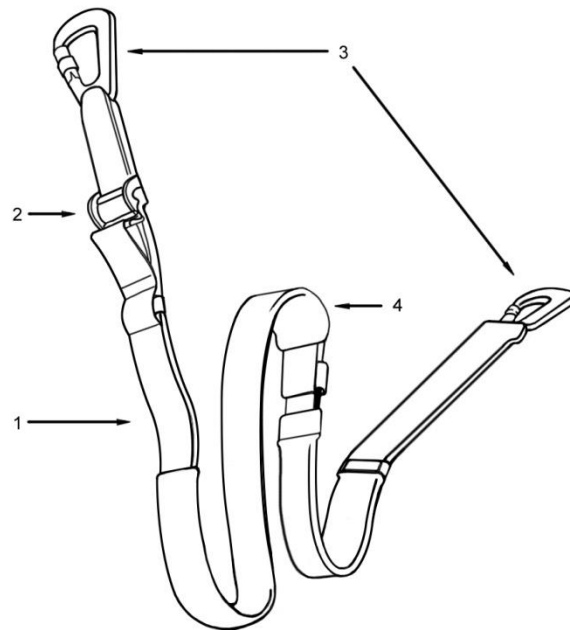

b) Example of an adjustable work positioning lanyard made from webbing

**Key**

- 1 Webbing lanyard
- 2 Adjustment device
- 3 Connectors
- 4 Protective sleeve

**Figure E.5 — Examples of adjustable work positioning lanyards used for fitting around a structure**



**Key**

- 1 Safety back-up (in this example, an energy-absorbing fall arrest lanyard coupled to an anchor sling)
- 2 Work positioning lanyard passed around structure
- 3 Work positioning lanyard attached to work positioning attachment point on harness (could be two side attachment points)

**Figure E.6 — Example of an adjustable work positioning lanyard being used for partial support (as a pole strap)**

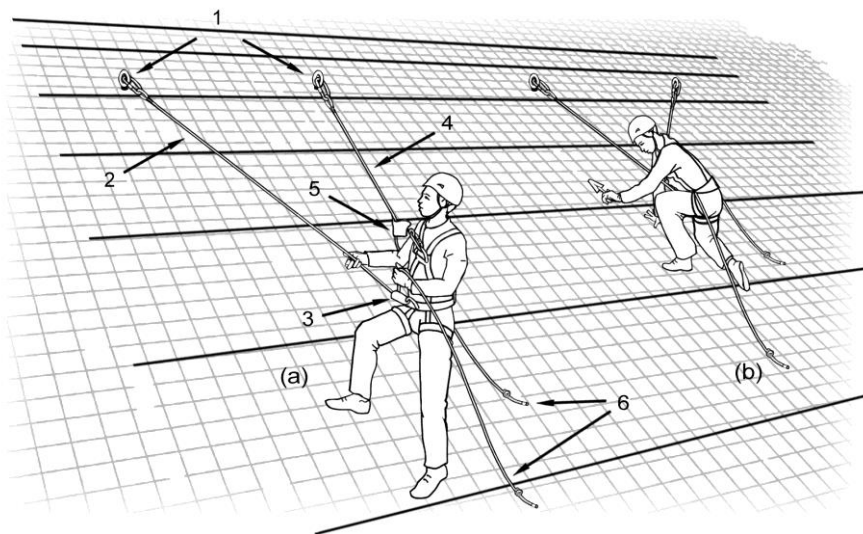

**Key**

- (a) Adjusting the length of the anchor line used as an adjustable work positioning lanyard
- (b) Worker supported by the anchor line being used as an adjustable work positioning lanyard

- 1 Anchor
- 2 Anchor line for work positioning and support (adjustable work positioning lanyard)
- 3 Adjustment device
- 4 Anchor line for safety back-up system
- 5 Fall arrest device
- 6 Spare length of anchor line with stopper knot or stopper device fitted

**Figure E.7 — Example of an adjustable work positioning lanyard, in this case an anchor line, being used for partial support**



**IRATA International code of practice  
for industrial rope access**

**Part 3: Informative annexes**

**Annex F: Safety considerations when installing or  
placing anchor devices for use in rope access**

**September 2013**

## Contents

Introduction .....	1
F.1 General.....	1
F.2 Installed anchor devices.....	2
F.2.1 General.....	2
F.2.2 Anchor rails and other rigid horizontal anchor lines .....	5
F.2.3 Paired anchor devices.....	7
1. F.2.4.....	Ground anchors 8
F.3 Placed anchor devices .....	11
F.3.1 General.....	11
F.3.2 Tripods and quadpods .....	11
F.3.3 Deadweight anchors .....	11
F.3.4 Counterweight anchors .....	14
F.3.5 Natural anchors (e.g. trees, rock) .....	17
F.3.6 Vehicles and mobile site machinery.....	18
F.3.7 Anchor connectors (e.g. scaffold hooks).....	19
F.3.8 Anchor slings.....	19
F.3.9 Beam clamps .....	19
F.4 Guidance on documentation to be supplied for permanently installed anchor devices.....	20
Figure F.1 — Examples of minimum spacing between anchor devices set in non-adjacent masonry units .....	4
Figure F.2 — Example of minimum spacing between anchor devices set in concrete to protect the cone of potential failure around each.....	4
Figure F.3 — Example of an anchor rail.....	6
Figure F.4 — Examples of paired anchor devices.....	8
Figure F.5 — Example of length, depth, spacing and angles of installation of ground anchor elements .....	10
Figure F.6 — Example layout for two ground anchors and connecting lines .....	10
Figure F.7 — Example of a tripod anchor device (in this example with working line and safety line rigged for rescue).....	12
Figure F.8 — Example of two deadweight anchor devices sharing the load .....	13
Figure F.9 — Example of a single counterweight anchor device being used as an anchor device for two anchor lines .....	15
Figure F.10 — Example of a calculation of the counterweight required for a counterweight anchor device.....	15
Figure F.11 — Examples of trees being used as anchorages .....	17
Figure F.12 — Examples of rock features being used as anchorages.....	18
Figure F.13 — Example of the use of anchor slings.....	19

The first edition of Annex F was published in August 2011.  
This edition was published in March 2013.

Amendments issued since publication in March 2013

Amd. No	Date	Text affected
1	2013-Sep-01	Front cover: <i>September 2013</i> replaces <i>2013 edition</i> . This page: change of IRATA address and telephone number. Date in footer updated. All the changes are classed as editorial.

Published by:

IRATA International  
First Floor, Unit 3  
Eurogate Business Park  
Ashford  
Kent  
TN24 8XW  
England

Tel: +44 (0)1233 754600

[www.irata.org](http://www.irata.org)

Copyright © IRATA International 2013

ISBN: 978-0-9544993-5-8

## Annex F (informative)

### Safety considerations when installing or placing anchor devices for use in rope access

#### Introduction

Annex F gives advice and other information that could be relevant to users of rope access methods and is one of a number of informative annexes in Part 3 of this code of practice. This informative annex should be read in conjunction with other parts of this code of practice, should not be used in isolation and is not intended to be exhaustive. For further advice, readers should refer to relevant specialist publications.

#### F.1 General

*NOTE* An explanation of various terms relating to anchors is provided in Part 1 via definitions and the accompanying Figure 1.1 in that part.

**F.1.1** There are many different types of anchor device. These generally fall into two broad categories: those that are installed into the structure or natural feature (*installed anchor devices*), e.g. eyebolts fixed to concrete, brick, block-work or steel beams; anchor rails; paired anchors; ground anchors, and those that are placed without installation into the structure or natural feature (*placed anchor devices*), e.g. tripods; scaffold hooks; deadweight anchors; counterweight anchors; anchor slings; beam clamps.

**F.1.2** The installation or placement of anchor devices should only be carried out from a safe place, i.e. a place arranged so that there is no risk of a fall from a height, and where there is a safe means of access and egress.

**F.1.3** When deciding where anchor devices are to be installed or placed, account should be taken of the envisaged work to be carried out from them, e.g. that the point where a descent starts is directly above the intended place of work.

**F.1.4** Anchor devices should be installed or placed in such a way that they can only be loaded in the directions intended by the manufacturer. Where this is difficult to achieve, special marking on or close to the anchor device which points out the limitations of loading might suffice. All aspects of installation, placement and use should follow the manufacturer's instructions.

**F.1.5** Anchor devices should be positioned so that attached anchor lines avoid contact with any hazardous surface, e.g. edges; abrasive or hot surfaces. If it is not possible or reasonably practicable to position the anchor devices in this way, the anchor lines should be appropriately protected against such hazardous surfaces, e.g. by the use of edge protectors or anchor line protectors (see **Part 2, 2.11.3**). This is essential for the safety of the user.

**F.1.6** Permanently installed and permanently placed rope access anchor systems should be provided with information relating to the installation or placement and with user instructions, see **F.4** for guidance. These anchor systems should be subjected to appropriate inspection and, where appropriate, testing procedures, which should be recorded.

**F.1.7** Anchor devices, or any component or element of them, should not be modified from the condition in which they were supplied without the manufacturer's written approval. This is because a modification might affect the performance of the anchor device and could also cause it to fall outside the manufacturer's specification.

**F.1.8** There is a responsibility on the installer (for installed anchor devices) or the person who placed the anchor (for placed anchor devices, if not temporary) to carry out detailed inspections or to have detailed inspections carried out for them by a competent person at regular intervals, which should be at least every six months. In addition, the user should carry out visual, tactile and, where appropriate, function checks on the anchor devices before each use. The checks and inspections



should cover signs of wear, corrosion, cracking or other defects and should include both the anchor device itself and the surrounding area.

**F.1.9** It is recommended that structures or natural features to be used for installation or placement of anchor devices are assessed by an engineer, unless it is clear to a competent person that the structure or natural feature is adequately stable and strong. An example of where an engineer might not be required is where an anchor sling of the correct capacity is secured around a solid permanent structure such as a plant room or large steel beam. If any doubt exists about the adequacy of the structure or natural feature, an engineer should make the assessment. The engineer should certify in writing that all combinations of loads in a worst-case situation can be safely withstood by the proposed structure or natural feature, bearing in mind that dynamic loads, e.g. under fall-arrest conditions, can be considerably higher than the static or quasi-static loads imposed by the rope access technician during normal rope access activities.

**F.1.10** The installation or placement of anchor devices should take account of recommendations in **Part 2, 2.7.9, 2.11.1** and **2.11.2** that the working line and the safety line should each be attached to its own independent anchor point. It should be noted that the anchor devices do not need to be of the same type: for example, the working line could be attached to an appropriately selected and installed eyebolt, while the safety line could be attached to an anchor sling placed around an appropriate steel beam. It is recommended that each anchor line is connected to both anchors for added security and arranged so that the load on each anchor line is shared equally between the two anchors. Account should be taken of the angles created between the anchor lines and the potential loads to the anchor devices: see **Part 2, Figure 2.4**.

**F.1.11** Some anchor devices are designed to deform at low loads to absorb energy. Before such anchor devices are used, confirmation should be obtained from the manufacturer that they are suitable for rope access use, including rescue. This is because intentionally deformable anchor devices are usually designed for a single fall arrest load and the continual low loading experienced in normal rope access activities could cause premature deformation and affect the energy-absorbing function.

**F.1.12** To protect the user against injury while transporting and assembling anchor devices, e.g. deadweight anchors; counterweight anchors; tripods, the size and mass of the anchor device or its component parts should be easily manageable and should take into account the requirements of local legislation and/or guidelines relating to manual handling.

## **F.2 Installed anchor devices**

**WARNING!** Anchor devices should only be installed by competent persons, who should be trained in the installation of each type of anchor device to be installed and for each type of base material into which they are to be installed. An IRATA rope access qualification at any level is not sufficient to assure competency to install or test anchor devices, or to carry out a detailed inspection of them. It should not be assumed that a Level 3 or other IRATA rope access technician is competent to install or inspect eyebolts or other specialist anchor systems.

### **F.2.1 General**

**F.2.1.1** **F.2** gives advice to consider when installing anchor devices for use in rope access. However, this advice does not replace proper training. Neither does it replace the need for a thorough understanding of and adherence to the information supplied by the manufacturer of the anchor devices or his authorized representative.

**F.2.1.2** Installation in this annex means the preparation of the structural material to which the anchor device is to be fitted (which is called the base material), e.g. by drilling a hole through steelwork or into concrete, rock, block-work, brickwork or other suitable materials; the fixing of the structural anchor to the base material, when such a structural anchor is to be fitted; and the attachment of the anchor device to the base material, either directly, e.g. into steelwork, or indirectly, e.g. via a structural anchor.

**F.2.1.3** Wherever anchor devices are to be installed, it is essential to ensure that the structure and base materials are of an appropriate type and have sufficient strength, quality, thickness and stability for the anchor device selected to withstand the loads that could be applied, e.g. in the event of a fall. This applies especially to brickwork, block-work or a combination of both. The installation of anchor devices should be such that they do not impair the integrity of the structure or natural feature.

**F.2.1.4** Installations should normally only be carried out in base materials intended by the manufacturer of the anchor device. The manufacturer should have carried out type tests of the anchor device installed in the base materials recommended. If no such type tests have been carried out or if there is no list of permitted base materials, it is recommended that trial tests are carried out as described in **F.2.1.7**.

**F.2.1.5** Fixings, e.g. bolts, recommended by the manufacturer of the anchor device for each type of base material as used in the type tests should be used. However, if alternative fixings are considered, their specification and performance should be checked to ensure they are at least as suitable as those originally specified and their suitability should be confirmed by the manufacturer of the anchor device.

**F.2.1.6** It should be noted that an installer who deviates from the installation instructions provided by the manufacturer and does not have authorisation from the manufacturer to do so (e.g. uses unapproved resins, non-type-tested substrates, alternative fixings or other components) takes on the rôle and responsibilities of the manufacturer for that aspect of the installation.

**F.2.1.7** Where the installation is intended to be made into a base material which was not included in the type tests or which was included in the type tests but whose actual strength is unknown (which could be less than that of the material in which the type tests were carried out), e.g. old brickwork, it is recommended that a series of three trial static strength tests be carried out to prove the reliability of the base material (sometimes known as substrate tests). The trial static strength tests should be carried out on samples of the anchor device installed as recommended by the manufacturer of the anchor device in a sample of the base material that is representative of the base material to which it is intended to install the anchor devices for the rope access work in hand. If these static strength tests are to be carried out on site, they should be well away from this work area. The static test load to be applied to the anchor device should be (15 +1/0) kN for (3 +0,25/0) min in the intended direction of use, e.g. in shear. The load should be applied gradually, i.e. as slowly as is practicable. Trial static strength tests for ground anchors should follow a different procedure, see **F.2.4**.

*NOTE 1 The trial static strength tests are not the same as the proof load tests carried out during a detailed inspection, which have a different test method and a recommended test load of 6 kN.*

*NOTE 2 The strength of concrete in existing structures is rarely known but can generally be safely assumed to be greater than 30N/mm<sup>2</sup>. Trial tests are therefore not needed in concrete structures if the type test was carried out in a sample of no more than 30N/mm<sup>2</sup>. Trial tests may be justified if the condition of the concrete has deteriorated sufficiently to suggest its strength may be lower than that of the test sample.*

**F.2.1.8** Holes for anchor devices to be installed in concrete, masonry or rock should be drilled strictly in accordance with the information supplied by the anchor device manufacturer, particularly in respect of depth and diameter, and thoroughly cleaned, e.g. by brushing and blowing or vacuuming, to remove any dust. Thorough cleaning is essential to ensure a good grip by the anchor device. It is also essential that the recommended embedment depth of fixings is never reduced. If an obstruction during drilling prevents this, the location of the fixings should be moved. An obstruction such as a reinforcing bar may be drilled through with the permission of a responsible engineer.

**F.2.1.9** Anchors for rope access are used in pairs (see **Part 2, 2.11.1 and 2.11.2**). When anchor devices are installed in concrete, rock, block-work or brickwork, it is essential that they are spaced apart correctly. This information should be provided by the manufacturer.

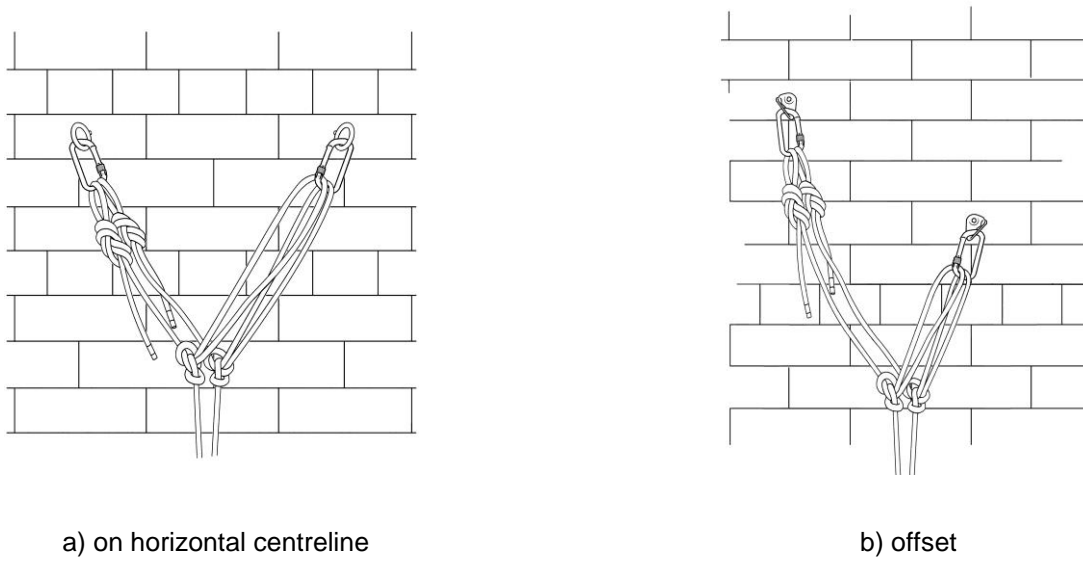

**Figure F.1 — Examples of minimum spacing between anchor devices set in non-adjacent masonry units**

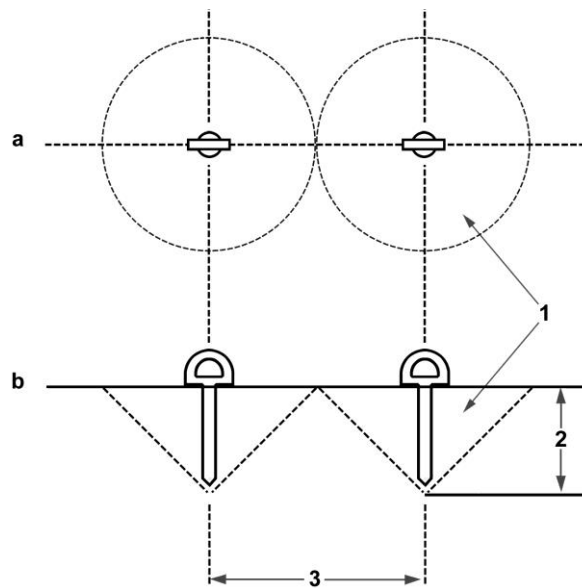

**Key**

- a Upper drawing: plan view
- b Lower drawing: side elevation
- 1 Areas of potential failure
- 2 Embedment depth
- 3 Minimum anchor spacing equal to or more than twice embedment depth

**Figure F.2 — Example of minimum spacing between anchor devices set in concrete to protect the cone of potential failure around each**

**F.2.1.10** In masonry, the anchor devices should not be installed in the same or adjacent masonry units. See **Figure F.1** for examples of minimum spacing. Anchor devices may be installed on a horizontal, diagonal or even vertical centreline. Where mortar joints are visible, the minimum spacing would be 350 mm and where the joints are not visible, the minimum spacing would be 500 mm.

**F.2.1.11** In materials such as rock or concrete, there is a need to protect the cone of potential failure around each anchor device. This cone is usually considered to have a maximum radius equal to the depth of the installed anchor, including any structural anchor, and thus affects the minimum spacing between the anchor devices: see **Figure F.2**. Attention is drawn to the need to take account of the effect of increased Y angles if the spacing between anchor devices is wide: see **Part 2, 2.11.2** and **Part 2, Figure 2.4**.

**F.2.1.12** Other factors that need to be addressed when deciding upon the spacings include:

- a) the strength and nature of the base material;
- b) the ability to share the load equally between the anchors.

**F.2.1.13** Installed anchor devices that are intended to be removed from the structure or natural feature during inspection should be inspected, taking account of the advice given in **Part 2, 2.7.9, 2.10** and **2.11.2**. Where any safety critical part of anchor devices (e.g. fixings) are covered during or after installation, e.g. by roofing materials, the visible parts should be inspected as recommended by the manufacturer and, at a period not exceeding ten years, the coverings should be removed and the anchor device should be inspected.

**F.2.1.14** For installed anchor devices that cannot be removed for detailed inspection at the recommended regular intervals, e.g. 6 months, the installer should provide information on the life expectancy of the anchor devices to the building owner, together with instructions to take the anchor devices out of service as soon as the life expectancy date has been reached.

## **F.2.2 Anchor rails and other rigid horizontal anchor lines**

**F.2.2.1** Anchor rails provide variable anchor points on a horizontal plane and are useful where a number of descents or ascents are required from the same plane, e.g. for maintenance to columns and rows of windows on the side of a building. They typically comprise appropriate metal tubing and brackets, which are usually fitted permanently to the structure. See **Figure F.3** for an example of an anchor rail.

**F.2.2.2** Attachment to an anchor rail is typically made by the use of two anchor slings passed around the anchor rail, each linked with an appropriate connector, to which the working line and the safety line are independently connected. Some anchor rails are fitted with travellers (mobile anchor points) to which the working line and safety line are independently connected.

**F.2.2.3** Anchor rails are a type of rigid horizontal anchor line. When attached correctly to a structure or natural feature, horizontal anchor lines (both rigid and flexible) can be considered to be a type of anchor device (which uses a mobile anchor point or points). If a type of rigid horizontal anchor line other than an anchor rail is chosen for use and it does not conform to a recognized standard, it is recommended that the testing, installation and use generally follow the same recommendations as those outlined in **F.2.2.4** to **F.2.2.7**.

*NOTE Flexible horizontal anchor lines are to be covered in the first revision of Annex L, Other harness-based work at height access methods, which is due to be published in the summer of 2013.*

**F.2.2.4** In the absence of any recognized standards for anchor rails, it is recommended that anchor rails are designed by a competent engineer. In addition, it is recommended that a static strength type test is carried out and that anchor rails (including any travellers, where travellers are intended to be used) are able to withstand a minimum static load of  $(15 + 1/0)$  kN for  $(3 + 0,25/0)$  min when the load is applied gradually, i.e. as slowly as is practicable, at:

- a) an extremity anchor;
- b) an intermediate anchor if one is fitted;
- c) the centre of the largest span;
- d) the centre of any span containing a joint in the anchor rail;
- e) the end of any cantilevered section.

**NOTE** A span is considered to be the distance between:

- a) extremity anchors (i.e. anchors at the ends of an anchor rail), where there is no intervening intermediate anchor;
- b) an extremity anchor and an intermediate anchor;
- c) two intermediate anchors.

**F.2.2.5** The type test should be carried out on a sample of the anchor rail installed as recommended by the manufacturer of the anchor rail in a sample of the base material that is representative of the base material to which it is intended to install the anchor rail for the rope access work in hand. If the type test is to be carried out on site, it should be well away from this work area. The static test load to be applied to the anchor rail should be in the intended direction of use, e.g. in shear.

**F.2.2.6** The static strength test described in **F.2.2.4** and **F.2.2.5** should be applied to the anchor rail via an anchor sling fitted to the anchor rail or, if the anchor rail system is intended to incorporate a traveller, via a traveller fitted to the anchor rail. During the test, yielding is acceptable but should take into account any necessary clearance distances required to avoid contact by the rope access technician with the ground or structure, should a fall occur.

**F.2.2.7** Normally, only one rope access technician should be attached to any one span of the anchor rail at any one time. When establishing the static strength of an anchor rail, the possibility of use by more than one person per span should be taken into consideration and the strength increased accordingly. Advice on what the increase should be is not given in this annex because opinions vary between different countries, their authorities and their standards bodies. Consideration should also be given to extra loads that may be imposed during rescue.

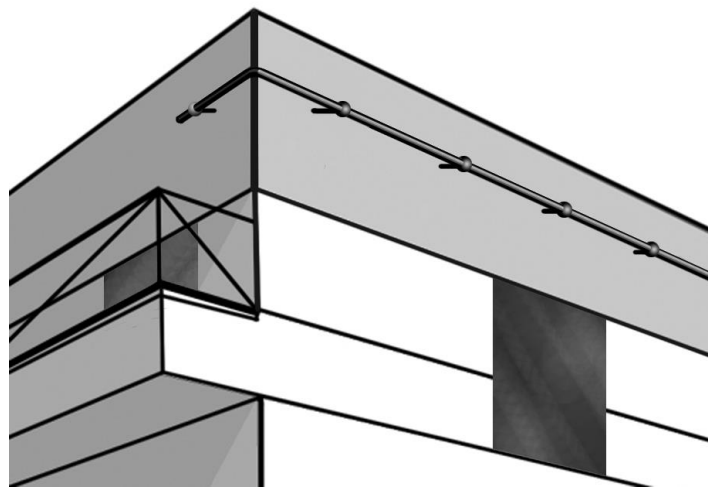

**Figure F.3 — Example of an anchor rail**

### F.2.3 Paired anchor devices

**F.2.3.1** A paired anchor device consists of two anchor points mounted on a single base and includes the elements (fixings) used to fix the paired anchor device to the base material. The base element of a paired anchor device is that part to which the anchor points are attached and which is used to attach the paired anchor device to the base material.

**F.2.3.2** There are several types of paired anchor device, see **Figure F.4**, with potential for more designs. A typical design is one where the base element of the paired anchor device is of a box type construction, with appropriate proprietary eyebolts attached to provide the anchor points. A typical application of paired anchor devices is installation to a flat roof structure made of concrete. The base element of the paired anchor device is usually partially or completely covered by roofing membranes or coatings after installation.

**F.2.3.3** Paired anchor devices may sometimes be fitted to walls or other inclined structures. It is recommended that they are not installed or used in brick constructions, either solid or cavity, or constructions of lightweight, thermal or hollow block-work, as the structure is unlikely to be able to withstand potential loads, especially fall arrest loads, which could be imposed as a result of foreseeable misuse. In any case, for this type of construction, other anchor options, e.g. multiple independent anchor devices, are likely to be more suitable than paired anchor devices. For other base materials, such as constructions of dense aggregate concrete blocks and other masonry constructions, the manufacturer should be consulted.

**F.2.3.4** Paired anchor devices may be used for personal fall protection purposes other than rope access. They should be designed, tested, selected and installed such that they also cater for fall arrest. Markings on the paired anchor device should indicate the uses permitted by the manufacturer.

**F.2.3.5** To avoid unwanted galvanic corrosion, all metal parts of the paired anchor device that could come into contact with each other should be of the same material. However, sometimes this is not possible or at least very difficult to achieve. If the various parts of the paired anchor device are manufactured from different metals, e.g. the anchor devices are made from stainless steel and the base element is made from galvanised carbon steel, it is essential they are isolated from each other at the time of installation (including within thread engagement areas). Any holes through which an anchor device is attached to the base element of the paired anchor device should be sealed to prevent the ingress of water.

**F.2.3.6** Unless otherwise specified by the manufacturer of the paired anchor device, all the fixing holes provided should be used when fixing the paired anchor device to the base material.

**F.2.3.7** Where as part of the installation it is intended to cover the base element of the paired anchor device with some form of waterproof membrane or coating, this should be done in such a way that there can be no ingress of water and in accordance with the information provided by the manufacturer.

**F.2.3.8** The pre-use check and inspection of paired anchor devices should follow the advice provided by the manufacturer and that given in **Part 2, 2.10**. Where paired anchor devices are intended to be removable, they should be removed during the detailed inspection. When paired anchor devices are partially covered by roofing materials such as waterproof membranes or coatings, it becomes difficult or impossible to carry out a full inspection, e.g. including the base plate and the fixings. In this case, the paired anchor devices may be considered as not being intended to be removable. However, there is a need at some stage to carry out an inspection of the whole paired anchor device. This is known as a complete inspection.

**F.2.3.9** Where paired anchor devices are not intended to be removed at the time of detailed inspection, then at intervals not exceeding ten years they should undergo a complete inspection. A sample of 5% per discrete site, chosen at random, with a minimum of at least two whole paired anchor devices, should be exposed by removing any coverings or coatings. Future samples for removal should be different from previous samples. The fixings should then be undone, their specification checked against the manufacturer's specification and the paired anchor device removed

for examination. The paired anchor device (including the fixings) should be disassembled as far as possible (e.g. if anchor points are removable, they should be removed) and the component parts examined for wear, corrosion, damage, deformation, degradation of plating or welds or any other defect. Any item showing any defect should be withdrawn from service and the sample rate doubled (i.e. a total of 10% or at least four paired anchor devices). Should any further defects be found, all the remaining paired anchor devices should be subjected to a complete examination.

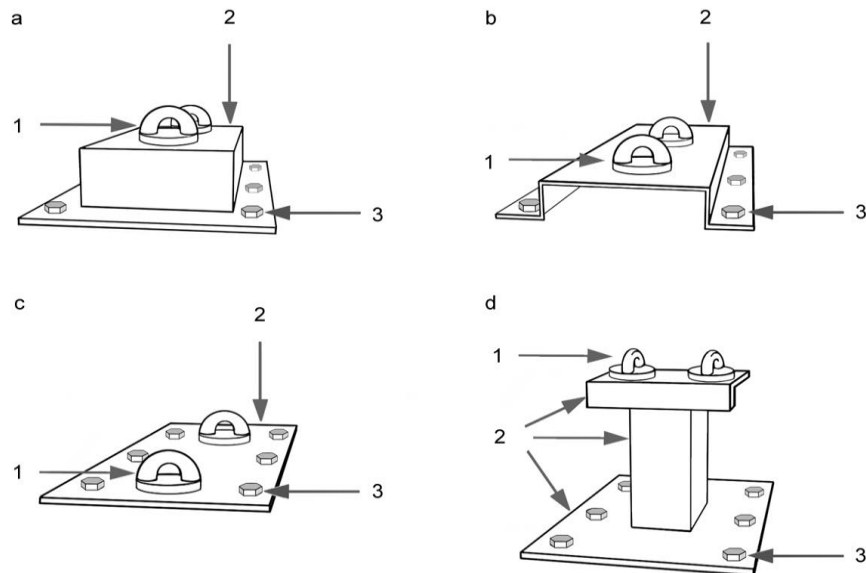

**Key**

- |   |                                 |   |              |
|---|---------------------------------|---|--------------|
| a | Box paired anchor device        | 1 | Anchor point |
| b | Saddle paired anchor device     | 2 | Base element |
| c | Flat plate paired anchor device | 3 | Fixing       |
| d | Pedestal paired anchor device   |   |              |

**Figure F.4 — Examples of paired anchor devices**

**F.2.4 Ground anchors**

**F.2.4.1** Ground anchors are driven or otherwise embedded into the base material, i.e. the ground, to which anchor lines are connected either directly or indirectly. They are generally used in situations where there are no other viable anchor alternatives.

**F.2.4.2** There is a variety of types of ground anchor. However, the guidance in this annex is limited to the type where metal stakes, typically made from steel or aluminium alloy, are driven into the ground and linked together with a connecting line.

**F.2.4.3** A ground anchor comprises the number of elements (ground anchor elements) inserted into the ground required to provide a reliable anchor of sufficient strength when the ground anchor elements are linked together.

**F.2.4.4** Ground anchors should always consist of more than one ground anchor element – usually, there are several – which should be linked together in such a way that the load is shared, see **Figure F.5**. When loaded, each inserted ground anchor element should be in equal tension with the others to maximize the load-bearing ability of the combination of them. The angle at which a connecting line or an attached anchor line emanates from the leading ground anchor element could

influence this load sharing detrimentally by applying unequal loading, so care should be taken to keep connecting lines and anchor lines in the correct orientation.

**F.2.4.5** Prior to installation, checks should be made to ensure the ground into which the ground anchors are to be installed does not contain any services, e.g. gas pipes, sewer pipes, drainage pipes, electricity cables, that are located where they could be damaged by the ground anchors.

**F.2.4.6** It is essential that each ground anchor element is strong enough for its intended task and has an adequate safety margin. Therefore, it is recommended that each ground anchor element should be capable of withstanding a static load of 15 kN for 3 min when tested in shear with the element fixed in an appropriate way in a suitable test rig. The static load should be applied gradually, i.e. as slowly as is practicable, at the attachment points or positions on the ground anchor element intended for the attachment of the anchor line or connecting line, as recommended by the manufacturer of the ground anchor element.

**F.2.4.7** The integrity of any installed ground anchor relies heavily on the resistance provided by the ground into which it is installed, which can vary from installation area to installation area or even within one installation area. Correct installation also relies greatly on the skills and experience of the installer and on a good risk assessment.

**F.2.4.8** It is recommended that the resistance provided and reliability of any area of ground used in the installation of ground anchors is proven. This can be achieved by carrying out trial static strength tests. These static strength tests should be carried out near but not at each worksite in an area that is representative of the ground in which it is intended to install the ground anchors for the rope access work in hand.

**F.2.4.9** An effective test method is to install one ground anchor element into the ground at the recommended backward leaning angle (see **F.2.4.11**) and then apply a load at the intended point of attachment for the anchor line in the intended direction of use. The load should be applied gradually, i.e. as slowly as is practicable. Record the peak load (up to a maximum of 15 kN for 3 min) at which it is pulled from the inserted angle to become vertical, or at which any part of a ground anchor breaks or fails in another way before reaching a vertical position. Then, divide that peak load into the minimum static strength required, which is 15 kN per single user. This gives an approximate number of ground anchor elements needed to be installed. As a precaution, at least one more ground anchor element should be added to the group.

**F.2.4.10** For greater confidence, the static strength test can be carried out on the full configuration of ground anchor elements (i.e. the ground anchor), which both on test and in use should always be linked together in such a way that the load is shared by all of them. The ground anchor should be tested in accordance with its intended configuration in use, in an area that is representative of the ground where it is intended to install the ground anchors for the rope access work in hand but, to avoid any possibility of weakening the ground, not at the worksite itself. The test should be considered to have failed if any ground anchor element moves from the inserted angle to become vertical, or if any part of a ground anchor breaks or fails in another way before reaching a vertical position.

**F.2.4.11** Tests have shown that a reliable ground anchor configuration can be achieved if the ground anchor elements are placed in line behind each other, about 1 m apart, in such a way that the loading during use follows that line. However, other configurations may be appropriate. The preferred length for ground anchors is 1 m and they should be installed into the ground by two thirds of their length at a backwards leaning angle from vertical of between 10° and 15°, see **Figure F.5**.

**F.2.4.12** The cross section of the metal stake used as a ground anchor element can affect its holding power in the ground. For example, in tests, the average strength for a 35 mm diameter round bar across various ground types was approximately 4 kN. The round bar version was outperformed by a ground anchor element made from 40 mm T section and 50 mm right-angled section by around 35% and 45% respectively. Employers should establish for themselves their preferred profile, e.g. by testing.



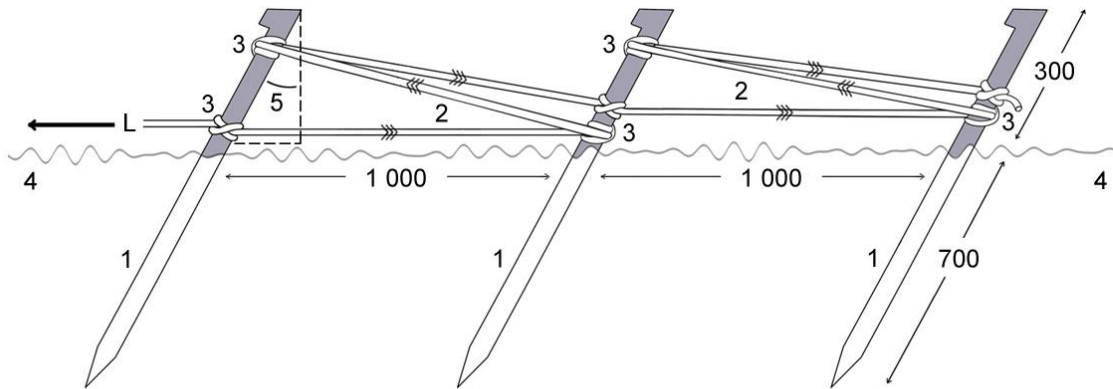

Dimensions are in mm and are approximate

**Key**

- 1 Ground anchor element
- 2 Connecting line (arrows show direction of fitting to ground anchor elements)
- 3 Clove hitch
- 4 Ground level
- 5 Angle of insertion of ground anchor element into ground (10° to 15° off vertical)
- L Load

**Figure F.5 — Example of length, depth, spacing and angles of installation of ground anchor elements**

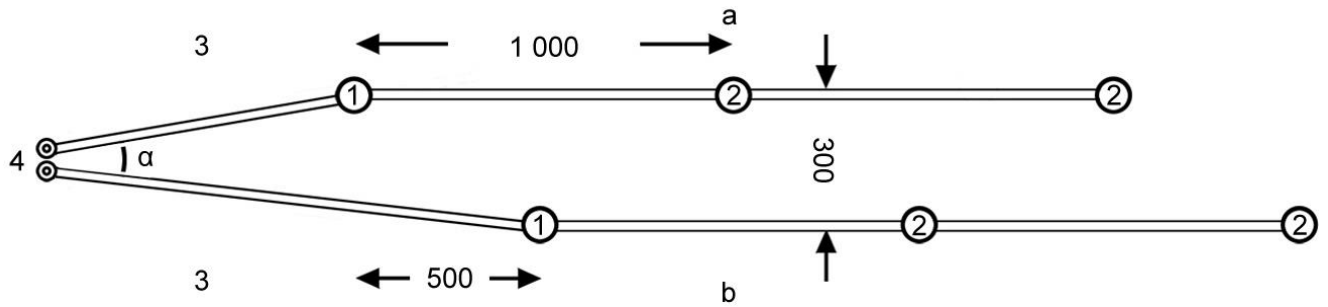

Dimensions are in mm and are approximate

**Key**

- a Ground anchor a with 3 ground anchor elements
- b Ground anchor b with 3 ground anchor elements offset from those in a
- 1 Leading ground anchor element
- 2 Ground anchor element
- 3 Connecting line
- 4 Connecting line terminations
- α Shallow included angle to help equalise loading on ground anchor elements

**Figure F.6 — Example layout for two ground anchors and connecting lines**

**F.2.4.13** A key factor in establishing a safe ground anchor configuration is the way in which the ground anchors are linked together, see **F.2.4.4**, which should be such that the load is shared as equally as possible by all the ground anchor elements from which the ground anchor is comprised. An example of one proven method is shown in **Figure F.5**. In this example, a connecting line, e.g. a length of 11 mm diameter low stretch kernmantel rope, is linked without slack to both the top and bottom of the part of the ground anchor element protruding from the ground, using clove hitches. This is terminated in a loop, e.g. by a figure of eight knot, to which an anchor line may be connected via an appropriate connector. An alternative is to terminate the connecting line at the leading ground anchor element and then to connect the anchor line directly to this leading ground anchor element.

**F.2.4.14** When the choice at a work site is to use only ground anchors, there should be a minimum of two ground anchors for each rope access system, see **a** and **b** in **Figure F.6**, to provide independent anchor points for the working line and the safety line.

**F.2.4.15** Tests have shown that an effective position for the second ground anchor (e.g. **b** in **Figure F.6**) is to install it approximately 300 mm away from and parallel to the first ground anchor (**a** in **Figure F.6**) and with the second ground anchor elements set approximately 500 mm back from the first ground anchor elements, i.e. so they are offset, e.g. as shown in **Figure F.6**.

**F.2.4.16** The included angle created by the connecting lines emanating from each leading ground anchor element should be such that all the ground anchor elements of each ground anchor are loaded as equally as possible.

**F.2.4.17** Designs and configurations of ground anchors not covered by this annex should be tested extensively and proved to be reliable before being put into use.

### **F.3 Placed anchor devices**

**CAUTION!** Anchor devices should only be placed by competent persons, who should have the experience or have been trained in the placement of each type of anchor device they intend to place.

#### **F.3.1 General**

**F.3** gives advice to consider when placing anchor devices for use in rope access. However, this advice does not replace proper training. Neither does it replace the need for a thorough understanding of and adherence to the information supplied by the manufacturer of the anchor devices or his authorized representative.

#### **F.3.2 Tripods and quadpods**

Tripods and quadpods can be used to provide an anchor point for the working line directly above the desired point of access, e.g. above a manhole, see **Figure F.7**. They should be positioned only on stable and even surfaces and placed in such a way that they cannot become accidentally dislodged during use. Tripods and quadpods should be able to withstand a static load of at least 15 kN when tested vertically downwards from the anchor point. This should be confirmed by the manufacturer. Account should be taken of the need for the safety line to be anchored independent of the tripod or quadpod, e.g. as shown in **Figure F.7**.

#### **F.3.3 Deadweight anchors**

**F.3.3.1** Deadweight anchors are one way of providing anchor points on roofs where no other appropriate anchor points exist. They typically comprise a weighted metal base with an anchor point to which an anchor line may be attached.

**F.3.3.2** The performance of a deadweight anchor or combination of deadweight anchors relies primarily on the amount of friction between the deadweight anchor device and the surface upon which it is placed, see **Figure F.8**. If the friction is insufficient, the deadweight anchor could slide out of position when submitted to a load such as that generated in a fall or during repetitive applications of loads such as those applied when descending or ascending the working line.

**F.3.3.3** The frictional resistance of any deadweight anchor system should be such that it does not slip when under a load that could be applied while work is being carried out from it, e.g. a fall generating 6 kN, with a safety factor of 2.5, i.e. 15 kN.

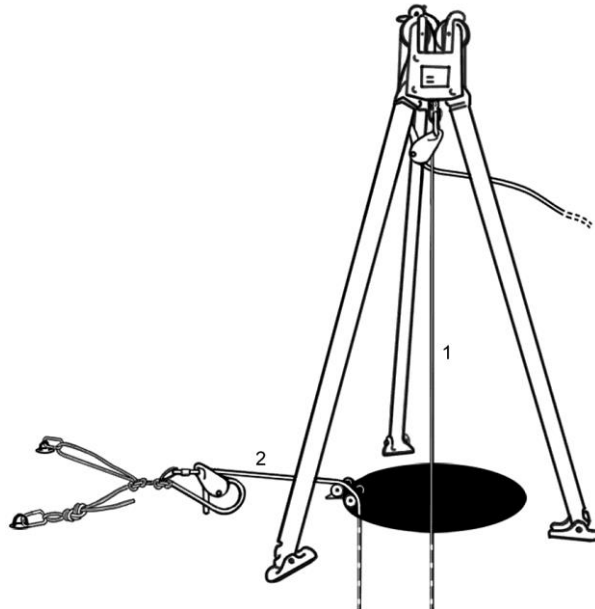

**Key**

- 1 Working line
- 2 Safety line

**Figure F.7 — Example of a tripod anchor device (in this example with working line and safety line rigged for rescue)**

**F.3.3.4** After testing and/or a risk assessment, a single deadweight anchor may be used if it is judged that it would have sufficient mass and frictional resistance to the ground to provide an unquestionably reliable anchorage for both the working line and the safety line, and that there are appropriate attachment points for these anchor lines. Where the frictional resistance of one deadweight anchor is insufficient, two or more deadweight anchors may be used. Their frictional resistance should be confirmed as sufficient by testing and/or risk assessment.

**F.3.3.5** Where two or more deadweight anchors are used, the working line and the safety line should be connected to all these deadweight anchors. The working line and the safety line should be arranged so that the load is shared equally between the deadweight anchors, to ensure that the minimum load at which they start to slip under load is over 15 kN, see **Figure F.8**.

**F.3.3.6** Consideration should be given to any potential rescue scenario, where the weight of two persons might have to be taken into account. This is likely to require the use of an additional deadweight anchor.

**F.3.3.7** The reduction of friction and the potential for inadvertent sliding of the deadweight anchor when subjected to a load can be caused in a number of ways:

- a) insufficient weight; weights attached incorrectly;

- b) insufficient roof surface roughness, e.g. caused by a smooth weather-proofing to the roof;
- c) inappropriate type of roof surface e.g. the type of roof ballast used;
- d) surface water, e.g. after rain;
- e) surface contaminants, e.g. lichen; moss; chemicals;
- f) icy conditions, e.g. caused by overnight freezing after rain;
- g) the roof angle and pitch, especially on a downward slope.

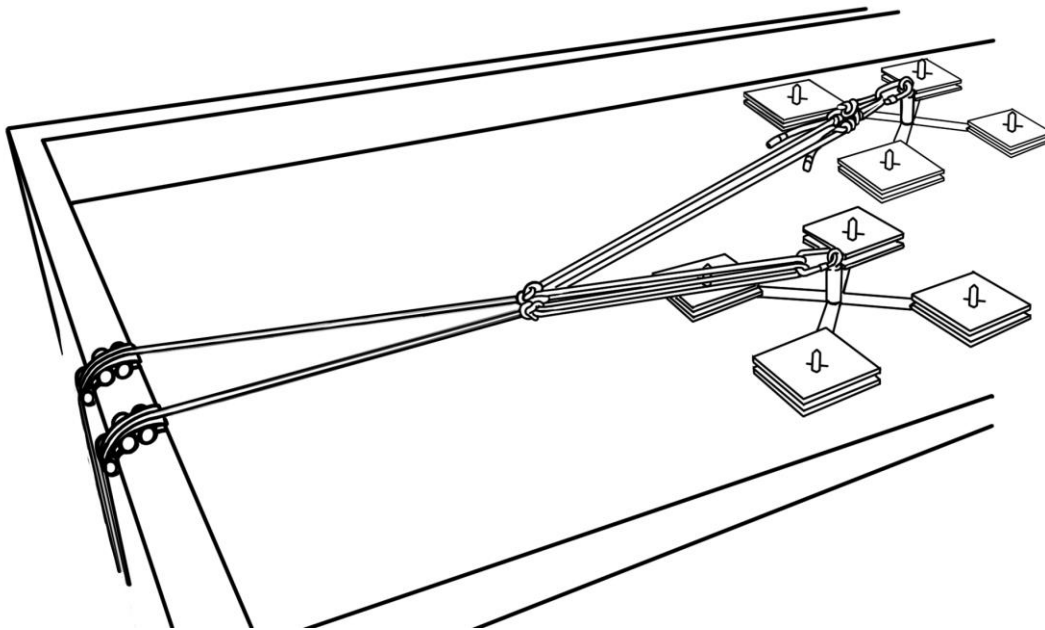

**Figure F.8 — Example of two deadweight anchor devices sharing the load**

**F.3.3.8** A deadweight anchor should be able to withstand a minimum static load of  $(15 \pm 1/0)$  kN for  $(3 \pm 0,25/0)$  min when tested in the test house with the base fixed and the load applied to the anchor point in the direction(s) intended in use. The load should be applied gradually, i.e. as slowly as is practicable. During the test, yielding is acceptable but should take into account any necessary clearance distances required to avoid contact by the rope access technician with the ground or structure, should a fall occur.

**F.3.3.9** The weights used with deadweight anchors should be made of a material that cannot leak or flow. Sand and/or water bags should not be used. Examples of appropriate materials for counterweights are steel, lead, concrete.

**F.3.3.10** The weights should be connected to the deadweight anchor in such a way that prevents them from becoming detached, e.g. by vibration sliding them out of position, and be protected against tampering, e.g. by chaining and locking them. Nevertheless, the weights should always be checked before each use.

**F.3.3.11** Other aspects that should be addressed when using deadweight anchors are:

- a) strictly follow the manufacturer's guidance;
- b) the maximum potential load that could be applied to the deadweight anchor;
- c) that there are sufficient weights and that these are correctly positioned on the frame of the deadweight anchor. (An insufficient number of weights and/or incorrectly positioned weights can cause the deadweight anchor to topple under load);
- d) that the strength of the roof is sufficient for the weights intended to be applied;
- e) that the minimum distance from the edge of the roof to the deadweight anchor is as specified by the manufacturer;
- f) that the presence of a parapet or upstand does not impede the functioning of the deadweight anchor device.

**F.3.3.12** Deadweight anchors should not be used in freezing conditions or when there is a risk of such conditions. Ice acts as a lubricant and is likely to severely reduce the coefficient of friction between the deadweight anchor and the surface of the roof.

**F.3.3.13** Deadweight anchors should not be used on any surface that is more than 5° sloping downwards from the horizontal. There are occasions where deadweight anchors can be placed on an upward slope, e.g. on the non-working side of a roof with a ridge, which would require the deadweight anchor device to travel up the slope if subjected to a load. In this case, the maximum recommended upward angle from the horizontal is 15°.

**F.3.3.14** It is recommended that deadweight anchors are backed up if possible, e.g. if there is an appropriate structural element of the building in the vicinity.

#### **F.3.4 Counterweight anchors**

**F.3.4.1** Counterweight anchors are another way of providing anchor points on roofs where no other appropriate anchor points exist. They typically comprise a metal base loaded with weights and an attached arm, with a support to provide a pivot point. The arm projects over the edge of the building to provide the descent/ascent take-off point for the rope access technician. The pivot point is the point from which the outer part of the arm becomes unsupported. See **Figure F.9** for an example of a counterweight anchor.

**F.3.4.2** After testing and/or a risk assessment, a single counterweight anchor may be used if it is judged that it would have sufficient mass to provide an unquestionably reliable anchorage for both the working line and the safety line, and that there are appropriate attachment points for these anchor lines. Where the mass of one counterweight anchor is insufficient, two or more counterweight anchors may be used. Their mass should be confirmed as sufficient by testing and/or risk assessment.

**F.3.4.3** Where two or more counterweight anchors are used, the working line and the safety line should be connected to all these counterweight anchors. The working line and the safety line should be arranged so that the load is shared equally between the counterweight anchors, to ensure that the minimum load at which they start to lift under load is over 15 kN.

**F.3.4.4** Consideration should be given to any potential rescue scenario, where the weight of two persons might have to be taken into account. This is likely to require the use of an additional counterweight anchor.

**F.3.4.5** The performance of a counterweight anchor relies primarily on the combination of the amount of mass placed at its inner end and, very importantly, the position of the pivot point towards the outer end of the arm, i.e. the end that projects over the edge of the structure. This combination has to be correct to prevent the weighted base from lifting from the surface on which it lies when it comes under load.

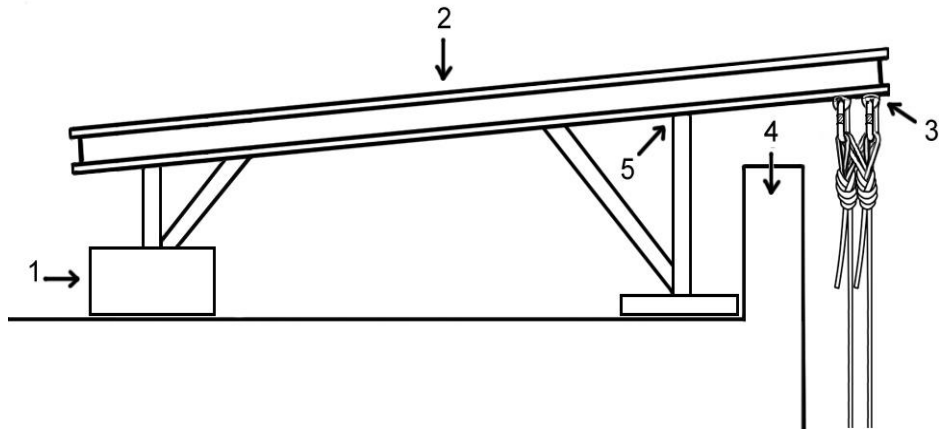

**Key**

- 1 Counterweight
- 2 Arm
- 3 Anchor points
- 4 Roof parapet
- 5 Pivot point

**Figure F.9 — Example of a single counterweight anchor device being used as an anchor device for two anchor lines**

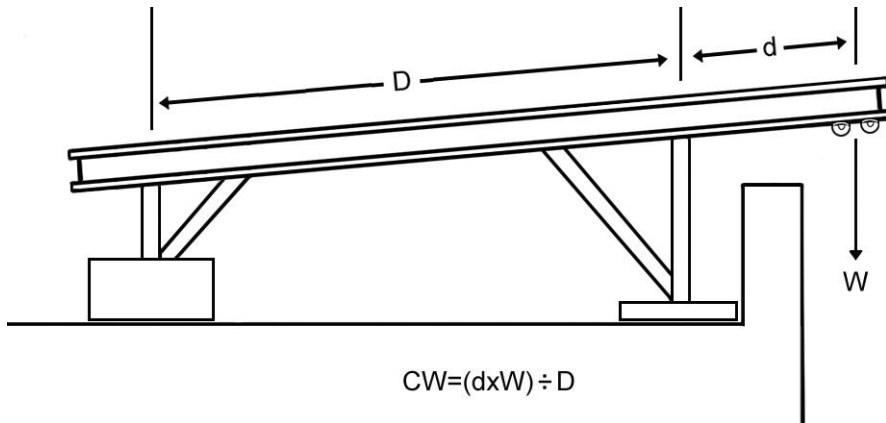

**Key**

- W Working design load (15 kN minimum)
- CW Minimum counterweight (mass) required (kg)
- d Length of outrigger from front support (mm)
- D Dimension from centre of anchor points to centreline of counterweight (mm)

**Figure F.10 — Example of a calculation of the counterweight required for a counterweight anchor device**

**F.3.4.6** It should be noted that counterweight anchors function differently from deadweight anchors. The primary function of the weighted base of a deadweight anchor is to provide enough friction between it and the roof surface to stop it from sliding out of position, not to stop it lifting from the roof surface, which is the primary function of the weighted base of counterweight anchors.

**F.3.4.7** Counterweight anchors work on the principle of a lever. The dimension from the pivot point to the outer end of the arm should be kept as short as possible, while the dimension from the pivot point to the counterweights should be as long as possible so that the number and mass of the weights required is kept to a minimum.

**F.3.4.8** Users should be aware that the cantilever length of different designs of counterweight anchor varies. This length affects the maximum cantilever capacity and this in turn the suitability for use in rope access.

**F.3.4.9** It is critically important that the pivot point of a counterweight anchor is established accurately. A small inaccuracy, say 50 mm, can make a large difference to the number of counterweights required. This is particularly so where the counterweight has a short arm or where the arm projects substantially beyond the pivot point. **Figure F.10** shows how to calculate the minimum counterweight required.

**F.3.4.10** Counterweight anchors are typically adapted for rope access from the swing stage (suspended platform) industry. Unless a counterweight anchor has been designed specifically for rope access, it is strongly recommended that an engineering assessment is made as to its suitability, bearing in mind that a load in a fall could be higher than that in normal swing stage use.

**F.3.4.11** The counterweight anchor should be able to withstand a minimum static load of  $(15 + 1/0)$  kN for  $(3 + 0,25/0)$  min without any permanent deformation or any movement of the counterweights from the surface on which they rest, when tested at the anchor point at the outer end of the arm, with the load applied gradually, i.e. as slowly as is practicable.

**F.3.4.12** Counterweights should be made of a material that cannot leak or flow. Sand and/or water bags should not be used. Examples of appropriate materials for counterweights are steel; lead; concrete.

**F.3.4.13** The counterweights should be connected to the arm in such a way that prevents them from becoming detached, e.g. by vibration sliding them out of position, and be protected against tampering, e.g. by chaining and locking them. Nevertheless, the counterweights should always be checked before each use.

**F.3.4.14** The arm should always be set up to be either horizontal or with a slight slope to the rear. Steep sloping of the arm should be avoided.

**F.3.4.15** The arm may be supported on purpose-made frames or on a built up scaffold frame. It is essential that the frame is designed for the loads to be imposed, which may be very high at the front, and also so that stability of the arm is ensured, including when the counterweights are fitted.

**F.3.4.16** The arm should only be rested on a parapet if it can be verified that the parapet is strong enough and stable enough to support the load, including any lateral load. This may require the services of an appropriate engineer. As many parapets are rendered, it may be necessary to verify that the substructure is satisfactory, particularly in the case of brickwork, or even pre-cast concrete where it may be strong enough in itself, but not attached well enough to the building to be stable. It should be noted that some parapets look solid but are made from materials inappropriate for use in the counterweight anchor system, e.g. plastic foam; timber framing; loose bricks.

**F.3.4.17** It is recommended that counterweight anchors are backed up if possible, e.g. if there is an appropriate structural element of the building in the vicinity.

**F.3.4.18** Rescue should only be carried out by lowering or lifting the casualty, i.e. the counterweight anchor should not be called upon to support the mass of two persons or more, unless this has been addressed at the design and assembly stage, e.g. see **F.3.3.8**.

### **F.3.5 Natural anchors (e.g. trees, rock)**

**F.3.5.1** There is no simple formula for assessing the strength of natural anchors. Use of these types of anchor relies on the experience of users and, sometimes, assessment by an engineer and/or other specialists. The selection of suitable natural anchors, such as trees, see **Figure F.11**, or rock features, e.g. spikes or bollards, see **Figure F.12**, for the placement of anchor slings requires a large amount of judgement, particularly in terms of their stability.

**F.3.5.2** Trees differ in their ability to withstand loads applied to their trunk or branches by species, size and time of year. Attention should be paid not only to the integrity of the trunk or branch to which attachment of the anchor sling is intended, but also to the integrity of the root system. Trunk or branch breakage or splitting, dead trunk or branches, rot and fungal growth, excessive insect activity and disturbance of the root system may all be indicators that the tree is not suitable for anchorage use. Anchor slings are best placed so that they cause as little leverage as possible, e.g. at the base of the trunk or close to the trunk if attached to a branch. Advice may be sought from specialist arborists.

**F.3.5.3** Rock features to be used as anchors should normally be part of the bedrock and should not exhibit any signs of fracturing or other defect that could cause their failure. Large boulders could be used if a risk assessment indicates sufficient integrity. The area at the back of a rock feature where any load would be applied by the anchor sling should have such characteristics that the anchor sling would not roll off it or be cut or badly abraded when in use, either during normal rope access activities or in the event of a fall. Sharp edges should be avoided or at least protected against. Dependent upon the precise use intended, consideration should be given to the possibility that the anchor sling might be inadvertently lifted off the rock feature during any upwards movement.

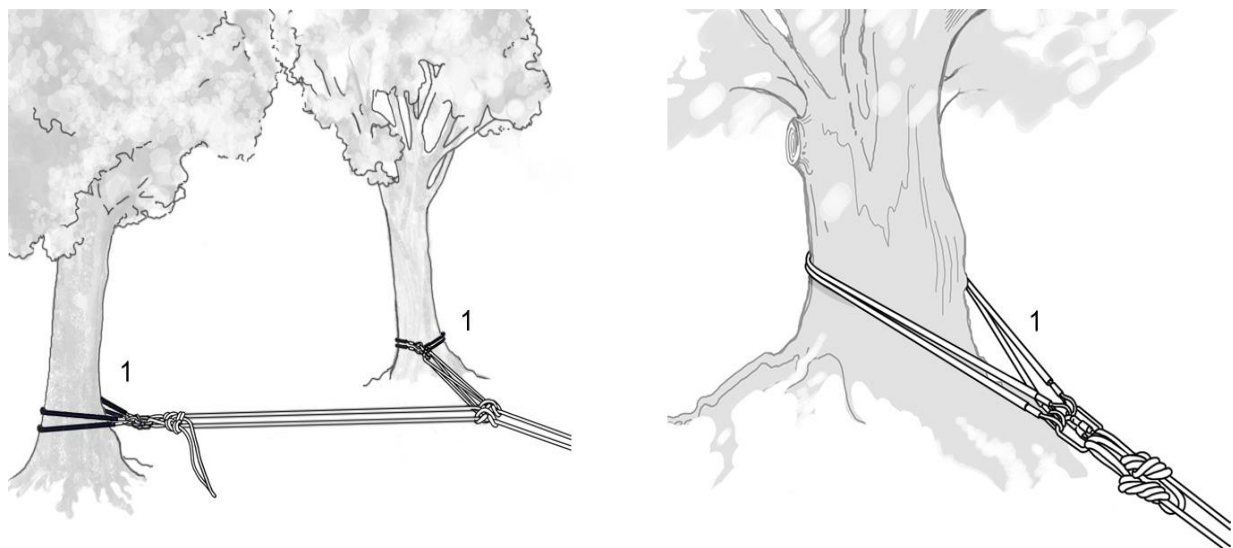

a) Two small trees

b) One large tree

#### **Key**

1 Two anchor slings, each with its own connector

**Figure F.11 — Examples of trees being used as anchorages**



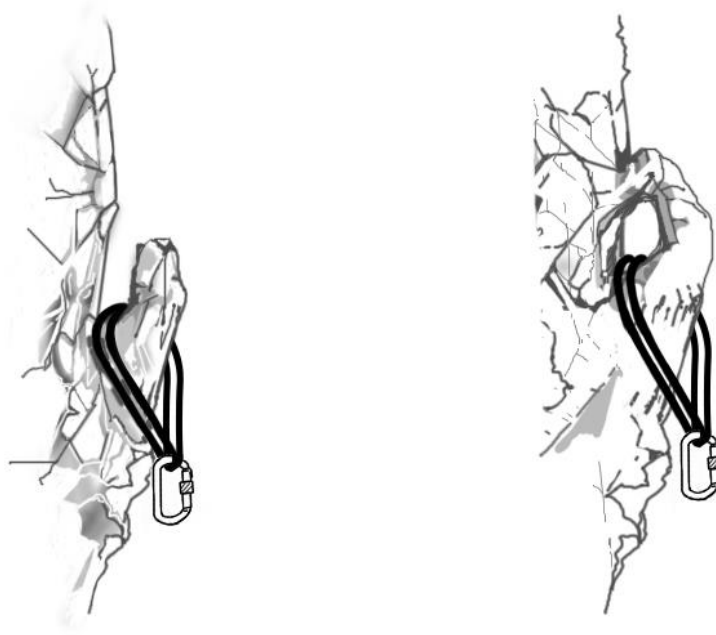

**Figure F.12 — Examples of rock features being used as anchorages**

### **F.3.6 Vehicles and mobile site machinery**

**F.3.6.1** Vehicles and mobile site machinery of various types can make effective anchors. Only reference to vehicles is made in the advice that follows but this advice may also be applied to any mobile site machinery considered for use as an anchor.

**F.3.6.2** After testing and/or a risk assessment, a single vehicle may be used as the anchor if it is judged that it would have sufficient mass and frictional resistance to the ground to provide an unquestionably reliable anchorage for both the working line and the safety line, and that there are appropriate attachment points for these anchor lines. Where the frictional resistance of one vehicle anchor is insufficient, two or more vehicle anchors may be used. Their frictional resistance should be confirmed as sufficient by testing and/or risk assessment. The working line and the safety line should be arranged so that the load is shared equally between the vehicles.

**F.3.6.3** When selecting attachment points, care should be taken to ensure no damage to the vehicle could occur, particularly to safety critical parts, e.g. hydraulic brake pipes, electrical cables.

**F.3.6.4** The surface upon which a vehicle is to stand during use as an anchor device should provide sufficient friction to avoid movement (sliding) of the vehicle should a load be applied such as that which could be applied during a fall, plus a safety factor of 2.5. It is recommended that this is checked before use by employing a load cell and a method of applying a pulling load, to confirm that there is no slippage under a minimum static load of  $(15 + 1/0)$  kN for  $(3 + 0,25/0)$  min when the load is applied gradually, i.e. as slowly as is practicable.

**F.3.6.5** There should be no possibility that the vehicle engines could be started or that the vehicle(s) could be moved, e.g. by being pushed or by being impacted by another vehicle. Correct isolation of the vehicle(s) should be ensured. Wheel chocking may be necessary. Barricading should be provided to make the vehicle(s) part of an exclusion zone. Signs warning of the dangers of unauthorized movement should be considered. A sentry may be required.

**F.3.6.6** Vehicles should never be used to tension an access system.

### F.3.7 Anchor connectors (e.g. scaffold hooks)

**F.3.7.1** When a connector is attached directly to the structure (as opposed to being attached to an anchor device), the connector effectively becomes an anchor device. See **Part 2, 2.7.4** for advice on connectors.

**F.3.7.2** When attaching any connector directly to the structure, great care should be taken during placement to avoid the possibility of a sideways loading should the connector be subjected to a load, e.g. the weight of a person or the force generated in a fall. This can happen when a connector is attached to an upright on the structure, e.g. a vertical scaffold pole or diagonal latticework on a mast. Connectors are weak when loaded sideways.

**F.3.7.3** It is important that an appropriate type of connector is selected when the intention is to connect directly to a structure. An example is a scaffold hook, which is a special but common kind of anchor connector with a large gate to enable attachment to wide diameter bars and tubes such as scaffolding poles, and has a shape to accommodate these.

### F.3.8 Anchor slings

Anchor slings may be used where there are no suitable anchors to which the anchor lines can be attached directly (see **Part 2, 2.7.8.3, 2.11.2.11** and **2.11.2.13** to **2.11.2.15** for further information). See **Figure F.13**. Other examples of their use are given in **Figures F.11** and **F.12**.

### F.3.9 Beam clamps

**F.3.9.1** Beam clamps can be useful in providing moveable anchor points on horizontal I-beams. Beam clamps and the I-beams to which they are to be attached should all be of sufficient strength for the planned work. It may require the services of a qualified engineer to ascertain this.

**F.3.9.2** When the choice at a work site is to use only beam clamps as anchors, there should be a minimum of two beam clamps for each rope access system to provide independent anchor points for the working line and the safety line.

**F.3.9.3** Beam clamps should be securely clamped to the I-beam before use.

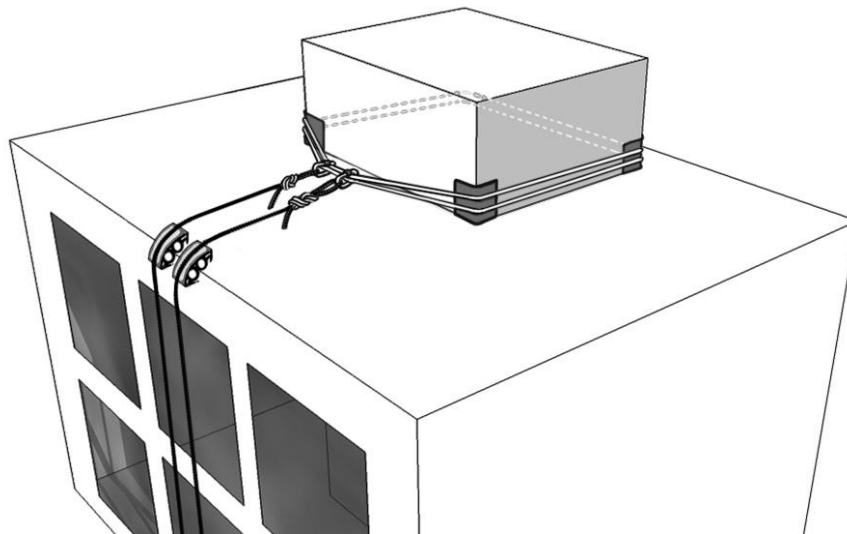

**Figure F.13 — Example of the use of anchor slings**

#### **F.4 Guidance on documentation to be supplied for permanently installed anchor devices**

**F.4.1** This guidance covers only permanently installed anchor devices. Permanent in this context means anchor devices that are intended to remain in place and to be re-used as and when required, e.g. not intended to be for a single, temporary use. Placed anchor devices are not covered in this guidance because they are not normally placed permanently. If they are placed permanently, the principles in this guidance should be able to be applied.

**F.4.2** The documentation produced after an installation of anchor devices is an essential part of a safe anchor system. For the client, it should provide evidence that the installation has been carried out properly. For the user, it should enable an appropriate and safe use of the anchor system. In addition, the documentation should provide sufficient information for it to be used as the basis for future periodic detailed inspections of the anchor devices. Bearing in mind that the fixings of many anchor devices are not visible or accessible, having accurate, detailed information for use in inspections is of the utmost importance.

**F.4.3** Permanently installed rope access anchor systems should be provided with user instructions, which should include a load rating, diagrams showing rigging examples, inspection procedures and, where appropriate, testing procedures.

**F.4.4** Once the installation of the anchor devices is completed, copies of the installation documentation should be given to the client. This documentation should be kept on site and be readily available for users and for use in subsequent periodic detailed inspections of the anchor devices.

**F.4.5** The installation documentation should contain at least the following information:

- a) the address and exact location of the installation of the anchor devices;
- b) client details, e.g. name; address; contact person; phone number; email address;
- c) installation company details, e.g. name; address; phone number; email address;
- d) the name and address of the person in charge of the installation of the anchor devices;
- e) details of the building material into which the anchor devices were installed, e.g. concrete ceiling; concrete column; reinforced concrete; concrete strength; minimum thickness;
- f) details of the anchor devices installed, e.g. manufacturer; type; model; serial number;
- g) details of any fixing device, e.g. manufacturer; type; model; serial number;
- h) fixing details, e.g. drill hole diameter; drill hole depth; method of forming hole (such as hammer/rotary drill) torque applied (torque control); drill hole clearing method; fitted wet or dry; minimum edge distances; minimum axial spacings; permissible tensile load; permissible shear load.

**F.4.6** It is recommended that a schematic installation plan is prepared, which shows relevant information for both users and inspectors. This could be attached to the structure in a place where it is visible or available for all relevant persons.

**F.4.7** As part of the schematic plan, it is recommended that each anchor point and its location are identified. This could be by a photograph or photographs of the anchor devices, which have been allocated numbers. This numbering could then be incorporated into the inspection (and test) protocols.

**F.4.8** There should be a signed declaration by the person in charge of the installation of the anchor devices at least that the anchor devices were:

- a) installed in accordance with the manufacturer's installation instructions;
- b) installed in accordance with the installation plan;
- c) fixed to the specified base material (substrate);
- d) fixed as specified, e.g. the correct number of bolts; the correct materials; the correct position; the correct location;
- e) commissioned in accordance with the information supplied by the manufacturer, e.g. checks and tests;
- f) supplied with information detailing the installation, e.g. photographs of the various stages of installation, especially when fixings (e.g. bolts) and the underlying substrate are not visible after completing the installation.



**IRATA International code of practice  
for industrial rope access**

**Part 3: Informative annexes**

**Annex G: Suspension intolerance**

**July 2014**

The first edition of Annex G was published in January 2010.  
This edition was published in March 2013.

Amendments issued since publication in March 2013

Amd. No	Date	Text affected
1	2013-Sep-01	Front cover: <i>September 2013</i> replaces <i>2013 edition</i> . This page: change of IRATA address and telephone number. Date in footer updated. All the changes are classed as editorial.
2	2014-Jul-10	Typo in G.2.4 corrected: reference to G.3 should be to G.1.3.

Published by:

IRATA International  
First Floor, Unit 3  
Eurogate Business Park  
Ashford  
Kent  
TN24 8XW  
England

Tel: +44 (0)1233 754600

Email: [info@irata.org](mailto:info@irata.org)

Website: [www.irata.org](http://www.irata.org)

Copyright © IRATA International 2014

ISBN: 978-0-9544993-5-8

## **Annex G (informative)**

### **Suspension intolerance (formerly known as suspension trauma)**

#### **Introduction**

Annex G gives advice and other information that could be relevant to users of rope access methods and is one of a number of informative annexes in Part 3 of this code of practice. This informative annex should be read in conjunction with other parts of this code of practice, should not be used in isolation and is not intended to be exhaustive. For further advice, readers should refer to relevant specialist publications.

**WARNING!** The advice given in this annex is known best practice at the time of publication. It is essential that persons responsible for rescue plans and rescues keep themselves fully up to date with current practices.

#### **G.1 General**

**G.1.1** Suspension intolerance is a condition in which a suspended person, e.g. in a harness, can experience certain unpleasant symptoms, which can lead to unconsciousness and eventually death. The reason for this is that the body is not tolerant of being in an upright position and motionless at the same time. Persons likely to be affected are those who are suspended in a generally upright position and who are motionless, for example, when seriously injured or unconscious, or when fastened vertically in a stretcher.

*NOTE* Suspension intolerance is also currently known by several other names, which include suspension trauma, orthostatic intolerance and harness-induced pathology.

**G.1.2** The condition has been suspected in cases of mountain climbers who fell and were then suspended for up to several hours. Some of these climbers died after rescue up to eleven days after their fall, for reasons that have been postulated by medical professionals as being due to suspension intolerance. There have also been instances of cave explorers becoming stuck on their ropes and who have died either while still on them or not long after being rescued. The reason for some of these deaths was again attributed to suspension intolerance. Some of the symptoms have been experienced by rescuees feigning unconsciousness in rescue training scenarios. The condition has been produced under experimental circumstances in persons who were suspended in a harness in a generally upright position and who were motionless. In these clinical trials, where the test subjects were told not to move, most experienced many of the effects of suspension intolerance, some including loss of consciousness, in just a few minutes. Others managed for longer before reporting symptoms. A similar situation might arise in a worker who falls into suspension and is not moving, e.g. due to being exhausted, badly injured or unconscious.

**G.1.3** Muscular action in moving the legs normally assists the return against gravity of blood in the veins back to the heart. When the body is motionless, these “muscle pumps” do not operate and if the person is in an upright position, an excess of blood pools in the veins of the legs, which are capable of a large expansion and, therefore, have considerable capacity. The excess of blood in the veins is known as venous pooling. The retention of blood in the venous system reduces the circulating blood volume and causes a disturbance of the circulatory system. This can lead to a critical reduction of blood supply to the brain and symptoms which include a feeling by the person that they are about to faint, nausea, breathlessness, disrupted vision, paleness, giddiness, localized pain, numbness, hot flushes, initially an increase in pulse and blood pressure and then a decrease in blood pressure below normal. The symptoms are known as pre-syncope and, if the condition is allowed to develop unchecked, can lead to unconsciousness (fainting) — when it is known as syncope — and eventually death. It is possible that other organs critically dependent on a good blood supply, such as the kidneys, could also suffer damage, with potentially serious consequences. It seems that even the fittest person may not be immune to the effects of suspension intolerance.

## **G.2 Advice**

**G.2.1** Normal movement of the legs (e.g. when ascending, descending or working while suspended) will activate the muscles, which should minimize the risk of excessive venous pooling and the onset of pre-syncope. It is recommended that harness leg-loops are wide and well-padded, as this should help to spread the load and reduce possible restrictions to blood-flow through the arteries and veins in the legs. The use of a work seat should be considered if one position is expected to be sustained for an extended period.

**G.2.2** Although there is little evidence of the effects of suspension intolerance occurring in the industrial rope access environment, an effective rescue plan is essential to ensure that, following an incident, a casualty can be removed quickly from the suspended position and cared for in a proper manner. The longer the casualty is suspended without moving, the greater the chances there are of the effects of suspension intolerance developing and the more serious it is likely to be.

**G.2.3** A person suspended motionless in a harness awaiting rescue is likely to tolerate suspension better with the knees elevated. During rescue, elevation of the legs and movement of them by the casualty or assisted by the rescuer, where safely possible, may be helpful. The casualty should be removed from suspension as soon as possible. This is particularly important for a casualty who is motionless.

**G.2.4** Rope access personnel should be able to recognise the symptoms of suspension pre-syncope, see **G.1.3**. Motionless head-up suspension can lead to pre-syncope and sometimes syncope in most normal subjects within 1 hour and to 20% of subjects within 10 minutes. Syncope can follow thereafter at an unpredictable time.

**G.2.5** During and after rescue, standard first-aid guidance should be followed, with an emphasis on airway, breathing and circulation management (ABC). Assessment of any injuries should include those which may not be apparent, e.g. damage to the neck, back and vital internal organs.

**G.2.6** In accordance with advice given in a literature research and assessment carried out by the UK Health and Safety Laboratory (HSL) in 2008 (HSE/RR708 *Evidence-based review of the current guidance on first aid measures for suspension trauma*), the fully conscious casualty may be laid down and the semi-conscious or unconscious casualty placed in the recovery position (also known as the open airway position). This differs from earlier advice.

**G.2.7** All casualties who have been suspended motionless in a harness should be taken to hospital immediately for further professional medical care and observation. Medical personnel should be advised that the casualty may be suffering from the effects of suspension intolerance.

**G.2.8** Those preparing rescue plans should regularly review current best practice.





**IRATA International code of practice  
for industrial rope access**

**Part 3: Informative annexes**

**Annex H: Equipment inspection checklist**

**September 2013**

The first edition of Annex H was published in December 2010.  
This edition was published in March 2013.

Amendments issued since publication in March 2013

Amd. No	Date	Text affected
1	2013-Sep-01	Front cover: <i>September 2013</i> replaces <i>2013 edition</i> . This page: change of IRATA address and telephone number. Date in footer updated. All the changes are classed as editorial.

Published by:

IRATA International  
First Floor, Unit 3  
Eurogate Business Park  
Ashford  
Kent  
TN24 8XW  
England

Tel: +44 (0)1233 754600

Email: [info@irata.org](mailto:info@irata.org)

Website: [www.irata.org](http://www.irata.org)

Copyright © IRATA International 2013

ISBN: 978-0-9544993-5-8

## **Annex H (informative)**

### **Equipment inspection checklist (non-exhaustive)**

#### **Introduction**

Annex H gives advice and other information that could be relevant to users of rope access methods and is one of a number of informative annexes in Part 3 of this code of practice. This informative annex should be read in conjunction with other parts of this code of practice, should not be used in isolation and is not intended to be exhaustive. For further advice, readers should refer to relevant specialist publications.

#### **H.1 General**

Annex H aims to supplement manufacturer's information provided with the item of equipment. Specific notices, inspection forms and particular points to verify, e.g. wear indicators, provided by the manufacturer should be understood and adhered to. Users of Annex H should be aware that different inspection regimes and use limitations (including lifetimes) may exist for similar products from different manufacturers.

#### **H.2 Inspection of equipment**

**H.2.1** An equipment inspection checklist is given in **Table H.1**. The table may be copied and used during inspections. However, the table is non-exhaustive and additional checks may need to be added, depending upon circumstances, e.g. equipment type and method of use; work task; environmental conditions.

**H. 2.2** It is recommended that each check box is marked appropriately after carrying out the inspection procedure, e.g. a tick  to show the check is satisfactory or a cross  to show the check is not satisfactory. Notes can be made in the left-hand column. See **Part 2, 2.10** for more information on the inspection, care and maintenance of equipment.

**H. 2.3** It is also recommended that the completed inspection checklist is filed and used as part of the next inspection. Comments marked against any piece of equipment can then be taken into consideration during the new inspection.

**H. 2.4** The equipment inspection checklist given in **Table H.1** is not intended to be a substitute for formal training in inspection. Detailed and interim inspections (see **Part 2, 2.10.1**) should only be carried out by competent persons.

**Table H.1 — Equipment inspection checklist**

Equipment	Inspection procedure
<p><b>All equipment manufactured from man-made fibres</b></p>	<p><i>These general checks apply to all equipment manufactured from man-made fibres</i></p> <ul style="list-style-type: none"> <li><input type="checkbox"/> I have read the information supplied by the manufacturer</li> <li><input type="checkbox"/> The equipment is within the manufacturer's recommended lifespan</li> <li><input type="checkbox"/> The equipment has not been subjected to loads in excess of the manufacturer's limitations</li> <li><input type="checkbox"/> The equipment has not been reported as having arrested a fall</li> </ul> <p>Carry out a visual and/or tactile check for:</p> <ul style="list-style-type: none"> <li><input type="checkbox"/> Excessive wear to any part</li> <li><input type="checkbox"/> Abrasion, particularly to load-bearing parts</li> <li><input type="checkbox"/> Any abrasion protection intended to be fitted is in place</li> <li><input type="checkbox"/> Furry webbing or rope (This usually indicates abrasion)</li> <li><input type="checkbox"/> Stitching: abraded, broken or cut</li> <li><input type="checkbox"/> Cuts, particularly to load-bearing parts</li> <li><input type="checkbox"/> Dirty webbing or rope (Dirt accelerates abrasion, both externally and internally)</li> <li><input type="checkbox"/> Legibility of marking for identification</li> <li><input type="checkbox"/> Evidence of unauthorized modification</li> <li><input type="checkbox"/> Damage by chemicals, e.g.                         <ul style="list-style-type: none"> <li><input type="checkbox"/> a powdery surface</li> <li><input type="checkbox"/> discolouration</li> <li><input type="checkbox"/> hardened areas</li> </ul> </li> </ul> <p>all of which can signify chemical contamination</p> <ul style="list-style-type: none"> <li><input type="checkbox"/> Damage by heat, e.g. glazed areas</li> </ul> <p>Actions:</p> <ul style="list-style-type: none"> <li><input type="checkbox"/> Equipment is beyond recommended lifespan: remove from service</li> <li><input type="checkbox"/> Equipment has been subjected to loads in excess of manufacturer's limitations: remove from service</li> <li><input type="checkbox"/> Equipment has been reported as having arrested a fall: remove from service</li> <li><input type="checkbox"/> Excessive wear to any part: remove from service</li> <li><input type="checkbox"/> Abrasion: if excessive, remove from service. A small amount of abrasion is permissible</li> <li><input type="checkbox"/> Intended abrasion protection is not in place: remove from service</li> <li><input type="checkbox"/> Stitching cut, broken or abraded: remove from service</li> <li><input type="checkbox"/> Cuts: remove from service</li> <li><input type="checkbox"/> Dirty: clean according to the manufacturer's instructions</li> <li><input type="checkbox"/> Marking for identification is not legible: ensure legibility before allowing the product into service</li> <li><input type="checkbox"/> Evidence of unauthorized modification: remove from service</li> <li><input type="checkbox"/> Chemical contamination: remove from service</li> <li><input type="checkbox"/> Heat damage: remove from service</li> </ul> <p>If in doubt on any point, remove from service</p>

Equipment	Inspection procedure
<p><i>Working lines and safety lines</i></p>	<p><input type="checkbox"/> Carry out all the appropriate general checks listed under the heading <i>All equipment manufactured from man-made fibres</i></p> <p>Additionally:</p> <p>Carry out a visual check on:</p> <ul style="list-style-type: none"> <li><input type="checkbox"/> Ends of anchor lines for excessive wear</li> <li><input type="checkbox"/> Inside and outside of any terminations, e.g. attachment-point loops, for wear</li> </ul> <p>Carry out a visual and tactile check:</p> <ul style="list-style-type: none"> <li><input type="checkbox"/> For contamination by grit, externally and internally, if possible</li> <li><input type="checkbox"/> For external and internal damage. On cable-laid ropes used as anchor lines (unusual), open up the lay and inspect as above. On kernmantel ropes, feel for unusually soft or hard areas, both on the sheath and the core. (This signifies damage.) Check particularly the ends of ropes</li> <li><input type="checkbox"/> That all knots are secure</li> <li><input type="checkbox"/> That knot overlaps are sufficient</li> </ul> <p>Actions:</p> <ul style="list-style-type: none"> <li><input type="checkbox"/> Excessive wear to any part of the anchor line: remove from service</li> <li><input type="checkbox"/> Excessive external and/or internal grit: clean in accordance with the manufacturer's instructions. If it is not possible to remove the grit, inspect the rope for damage by abrasion more frequently than normal</li> <li><input type="checkbox"/> Unusually soft or hard areas: remove from service. (Sometimes, the damage is only local, so damaged areas can be cut out.)</li> <li><input type="checkbox"/> Knots: if in doubt, remove from service. Knots may be retied by a competent person. Tension knots with body weight and ensure that there is sufficient overlap (minimum 100 mm). If the knots in an anchor line appear to be very tight, either retie the knots or replace the anchor line</li> </ul> <p>If in doubt on any point, remove from service</p>

Equipment	Inspection procedure
<p><i>Harnesses</i></p>	<p><input type="checkbox"/> Carry out all the appropriate general checks listed under the heading <i>All equipment manufactured from man-made fibres</i></p> <p>Additionally:</p> <p>Carry out a visual and tactile check:</p> <p><input type="checkbox"/> Inside and outside any terminations, e.g. textile attachment-point loops, for all the points listed under the general checking procedure</p> <p><input type="checkbox"/> on fastening and adjustment buckles for:</p> <ul style="list-style-type: none"> <li><input type="checkbox"/> Correct assembly</li> <li><input type="checkbox"/> Correct functioning</li> <li><input type="checkbox"/> Excessive wear</li> <li><input type="checkbox"/> Corrosion</li> <li><input type="checkbox"/> Cracks</li> <li><input type="checkbox"/> Other damage</li> </ul> <p>Actions:</p> <p><input type="checkbox"/> Textile terminations: treat in accordance with the general checking procedure</p> <p><input type="checkbox"/> Fastening and adjustment buckles, other safety critical metal or plastics components:</p> <ul style="list-style-type: none"> <li><input type="checkbox"/> Incorrect assembly: correct assembly</li> <li><input type="checkbox"/> Incorrect functioning: remove from service</li> <li><input type="checkbox"/> Excessive wear: remove from service</li> <li><input type="checkbox"/> Corrosion: remove from service</li> <li><input type="checkbox"/> Cracks: remove from service</li> <li><input type="checkbox"/> Other damage: remove from service</li> </ul> <p>If in doubt on any point, remove from service</p>

Equipment	Inspection procedure
<i>Lanyards and slings</i>	<p><input type="checkbox"/> Carry out all the appropriate general checks listed under the heading <i>All equipment manufactured from man-made fibres</i></p> <p>Additionally:</p> <p>Carry out a visual and tactile check:</p> <ul style="list-style-type: none"><li><input type="checkbox"/> Inside and outside any terminations, e.g. textile attachment-point loops, for all the points listed under the general checking procedure</li><li><input type="checkbox"/> All knots for security</li><li><input type="checkbox"/> That knot overlaps are sufficient</li><li><input type="checkbox"/> That knots in anchor lanyards and device lanyards are not too tight (i.e. that they would still provide some energy absorption)</li></ul> <p>Actions:</p> <ul style="list-style-type: none"><li><input type="checkbox"/> Textile terminations: treat in accordance with the general checking procedure</li><li><input type="checkbox"/> Knots: if in doubt, remove from service. Knots may be retied by a competent person. Tension knots with body weight and ensure that there is sufficient overlap (minimum 100 mm). If the knots in an anchor lanyard or device lanyard appear to be very tight, either retie the knots or replace the lanyard.</li></ul> <p>If in doubt on any point, remove from service</p>

Equipment	Inspection procedure
<i>Energy absorbers</i>	<input type="checkbox"/> Carry out all the appropriate general checks listed under the heading <i>All equipment manufactured from man-made fibres</i>  Additionally:  Carry out a visual and tactile check:  <input type="checkbox"/> Inside and outside any terminations, e.g. textile attachment-point loops, for all the points listed under the general checking procedure <input type="checkbox"/> That there are no signs of any deployment (i.e. partial activation) of the energy absorber  Actions:  <input type="checkbox"/> Textile terminations: treat in accordance with the general checking procedure <input type="checkbox"/> Any sign of deployment: remove from service  If in doubt on any point, remove from service



Equipment	Inspection procedure
<p><b>All metallic equipment</b></p>	<p><i>These general checks apply to all equipment manufactured from metal</i></p> <ul style="list-style-type: none"> <li><input type="checkbox"/> I have read the information supplied by the manufacturer.</li> <li><input type="checkbox"/> The equipment is within the manufacturer's recommended lifespan.</li> <li><input type="checkbox"/> The equipment has not been subjected to loads in excess of the manufacturer's limitations</li> <li><input type="checkbox"/> The equipment has not been reported as having arrested a fall</li> </ul> <p>Carry out a visual and/or tactile check for:</p> <ul style="list-style-type: none"> <li><input type="checkbox"/> Build up of foreign matter, e.g. grit; grease; sealant; paint</li> <li><input type="checkbox"/> Wear, particularly to friction-inducing surfaces, e.g. bobbins, and wear indicators, where present</li> <li><input type="checkbox"/> Cuts</li> <li><input type="checkbox"/> Heavy marking or scoring and crazing of surface finish (crazing often indicates distortion)</li> <li><input type="checkbox"/> Burring</li> <li><input type="checkbox"/> Cracks</li> <li><input type="checkbox"/> Corrosion, e.g. rusting; stress corrosion cracking; galvanic corrosion</li> <li><input type="checkbox"/> Contamination by chemicals</li> <li><input type="checkbox"/> Deformation, e.g. twisted</li> <li><input type="checkbox"/> Evidence of unauthorized modification</li> </ul> <p>Actions:</p> <ul style="list-style-type: none"> <li><input type="checkbox"/> Equipment is beyond recommended lifespan: remove from service</li> <li><input type="checkbox"/> Equipment has been subjected to loads in excess of manufacturer's limitations: remove from service</li> <li><input type="checkbox"/> Equipment has been reported as having arrested a fall: remove from service</li> <li><input type="checkbox"/> Remove any foreign matter</li> <li><input type="checkbox"/> Excessive wear: remove from service. Some wear is permissible: refer to manufacturer's information</li> <li><input type="checkbox"/> Cuts, heavy burring, marking or scoring, crazing of surface finish: remove from service</li> <li><input type="checkbox"/> Cracks: remove from service</li> <li><input type="checkbox"/> Bad corrosion: remove from service</li> <li><input type="checkbox"/> Contamination by chemicals: remove from service</li> <li><input type="checkbox"/> Deformation: remove from service</li> <li><input type="checkbox"/> Evidence of unauthorized modification: remove from service</li> </ul> <p>If in doubt on any point, remove from service</p>

<b>Equipment</b>	<b>Inspection procedure</b>
<i>Descending devices</i>	<p><input type="checkbox"/> Carry out all the appropriate general checks listed under the heading <i>All metallic equipment</i></p> <p>Additionally:</p> <p>Carry out a visual and tactile check to ensure:</p> <ul style="list-style-type: none"><li><input type="checkbox"/> Moving parts function correctly, e.g. handles; locking devices; cams; springs; locking catches</li><li><input type="checkbox"/> Hinge pins are in good condition</li><li><input type="checkbox"/> Threaded assemblies are fully tightened and correctly secured</li></ul> <p>Actions:</p> <ul style="list-style-type: none"><li><input type="checkbox"/> Incorrect functioning: remove from service. If any moving parts do not function correctly, remove from service</li><li><input type="checkbox"/> Hinge pins not in good condition: remove from service</li><li><input type="checkbox"/> Threaded assemblies not properly tightened or are unable to be tightened if it is the intention that the user may do so: remove from service and correct the problem</li></ul> <p>If in doubt on any point, remove from service</p>

Equipment	Inspection procedure
<i>Ascending devices/Back-up devices</i>	<p><input type="checkbox"/> Carry out all the appropriate general checks listed under the heading <i>All metallic equipment</i></p> <p>Additionally:</p> <p>Carry out a visual and tactile check to ensure:</p> <ul style="list-style-type: none"><li><input type="checkbox"/> Moving parts function correctly, e.g. cam; springs; locking catch</li><li><input type="checkbox"/> There is no damage to cams, e.g. broken teeth</li><li><input type="checkbox"/> Hinge pin is in good condition</li><li><input type="checkbox"/> Threaded assemblies are fully tightened and correctly secured</li></ul> <p>Actions:</p> <ul style="list-style-type: none"><li><input type="checkbox"/> Incorrect functioning: remove from service. If any moving parts do not function correctly, remove from service</li><li><input type="checkbox"/> Hinge pin not in good condition: remove from service</li><li><input type="checkbox"/> Threaded assemblies not properly tightened or are unable to be tightened if it is the intention that the user may do so: remove from service and correct the problem</li></ul> <p>If in doubt on any point, remove from service</p>

Equipment	Inspection procedure
<i>Connectors</i>	<p><input type="checkbox"/> Carry out all the appropriate general checks listed under the heading <i>All metallic equipment</i></p> <p>Additionally:</p> <p>Carry out a visual and tactile check to ensure:</p> <ul style="list-style-type: none"><li><input type="checkbox"/> Moving parts function correctly, e.g. keeper locates in body correctly; spring returns the keeper correctly; keeper locking mechanism operates correctly (screw gate, twist-lock); any threaded parts run correctly</li><li><input type="checkbox"/> Hinge pin is in good condition</li><li><input type="checkbox"/> Catch pin is not bent</li></ul> <p>Actions:</p> <ul style="list-style-type: none"><li><input type="checkbox"/> Incorrect functioning: if any moving parts do not function correctly, remove from service</li><li><input type="checkbox"/> Hinge pin not in good condition: remove from service</li><li><input type="checkbox"/> Catch pin bent: remove from service</li></ul> <p>If in doubt on any point, remove from service</p>

Equipment	Inspection procedure
<p><i>Lanyards and slings made from metal, e.g. wire strops</i></p>	<p><input type="checkbox"/> Carry out all the appropriate general checks listed under the heading <i>All metallic equipment</i></p> <p>Additionally:</p> <p>Carry out a visual check for:</p> <p><input type="checkbox"/> Wear or damage to wire strands inside and outside the attachment-point loops and that the attachment-point loop terminations are undamaged and secure</p> <p><input type="checkbox"/> Excessive wear to any other part, especially load-bearing parts, e.g. broken wire strands</p> <p>Carry out a visual and tactile check to ensure:</p> <p><input type="checkbox"/> Any abrasion protection intended to be fitted is in place</p> <p><input type="checkbox"/> Any moving parts function correctly</p> <p>Actions:</p> <p><input type="checkbox"/> Wear or damage to wire strands inside and outside the attachment-point loops: remove from service</p> <p><input type="checkbox"/> Excessive wear or damage to any other part: remove from service. Some wear is permissible: refer to manufacturer's information</p> <p><input type="checkbox"/> Any abrasion protection intended to be fitted is not in place or is damaged: remove from service</p> <p><input type="checkbox"/> Incorrect functioning: if any moving parts do not function correctly, remove from service</p> <p>If in doubt on any point, remove from service</p>

Equipment	Inspection procedure
<b>Helmets</b>	<p> <input type="checkbox"/> I have read the information supplied by the manufacturer.  <input type="checkbox"/> The helmet is within the manufacturer's recommended lifespan.  <input type="checkbox"/> The helmet has not been subjected to loads in excess of the manufacturer's limitations                 </p> <p>Carry out a visual and tactile check for:</p> <p> <input type="checkbox"/> Cracks, deformation or other damage to the shell  <input type="checkbox"/> Damage to the cradle/chinstrap assembly  <input type="checkbox"/> Excessive wear to any part  <input type="checkbox"/> Evidence of unauthorized modification                 </p> <p>Check that:</p> <p> <input type="checkbox"/> The chin strap adjusts fully and easily to achieve a correct fit  <input type="checkbox"/> The headband adjusts fully and easily to achieve a correct fit  <input type="checkbox"/> Labels, e.g. self-adhesive labels ('stickers'), placed on helmets not by the manufacturer are in accordance with the helmet manufacturer's instructions                 </p> <p>Actions:</p> <p> <input type="checkbox"/> Helmet beyond recommended lifespan: remove from service  <input type="checkbox"/> Helmet has been subjected to loads in excess of manufacturer's limitations: remove from service  <input type="checkbox"/> Any cracks, deformation or other damage, including scoring or cuts to the shell: remove from service  <input type="checkbox"/> Damage to the cradle/chinstrap assembly: remove from service  <input type="checkbox"/> Excessive wear to any part: remove from service  <input type="checkbox"/> Evidence of unauthorized modification: remove from service  <input type="checkbox"/> No chin strap, or chin strap does not adjust fully and easily: remove from service  <input type="checkbox"/> Headband does not adjust fully and easily: remove from service  <input type="checkbox"/> Headband adjustment does not stay in position: remove from service  <input type="checkbox"/> Labels placed on helmets that are not in accordance with the helmet manufacturer's instructions: remove from service                 </p> <p>If in doubt on any point, remove from service</p>



**IRATA International code of practice  
for industrial rope access**

**Part 3: Informative annexes**

**Annex I: List of information to be recorded following  
a detailed inspection of rope access equipment**

**September 2013**

The first edition of Annex I was published in January 2010.  
This edition was published in March 2013.

Amendments issued since publication in March 2013

Amd. No	Date	Text affected
1	2013-Sep-01	Front cover: <i>September 2013</i> replaces <i>2013 edition</i> . This page: change of IRATA address and telephone number. Date in footer updated. All the changes are classed as editorial.

Published by:

IRATA International  
First Floor, Unit 3  
Eurogate Business Park  
Ashford  
Kent  
TN24 8XW  
England

Tel: +44 (0)1233 754600

Email: [info@irata.org](mailto:info@irata.org)

Website: [www.irata.org](http://www.irata.org)

Copyright © IRATA International 2013

ISBN: 978-0-9544993-5-8



## **Annex I (informative)**

### **List of information to be recorded following a detailed inspection of rope access equipment**

#### **Introduction**

Annex I gives advice and other information that could be relevant to users of rope access methods and is one of a number of informative annexes in Part 3 of this code of practice. This informative annex should be read in conjunction with other parts of this code of practice, should not be used in isolation and is not intended to be exhaustive. For further advice, readers should refer to relevant specialist publications.

#### **I.1 General**

It is recommended that a detailed inspection of rope access equipment is recorded. The detailed inspection and information recorded should take into account manufacturers' recommendations and the work environment. The documentation should be kept for at least two years, or longer if required by local legislation.

#### **I.2 Information recommended to be recorded**

The recorded information should include at least the following:

- a) the name and address of the employer for whom the detailed inspection was made;
- b) the address of the premises (or site) at which the detailed inspection was made;
- c) information sufficient to identify the equipment, e.g. a serial number, including, where known, the date of manufacture;
- d) the date of:
  - 1) first use;
  - 2) the last detailed inspection;
  - 3) the latest date for the next detailed inspection;
- e) as marked on the equipment and/or in the information supplied by the manufacturer, the maximum rated load (and minimum rated load where appropriate) or its safe working load or its working load limit or their equivalents, taking into account the configurations in which the equipment might be used, which should be acceptable by the manufacturer;

*NOTE If equipment is to be used outside of the manufacturer's recommendations, the risks associated with doing so should be assessed and then discussed with the manufacturer or his authorized representative.*

- f) if it is the first detailed inspection:
  - 1) that it is the first detailed inspection;
  - 2) that it functions correctly and is safe to use;
- g) if it is not the first detailed inspection:
  - 1) whether it is a detailed inspection:
    - (i) within an interval of 6 months;

- (ii) in accordance with time intervals specified in an inspection scheme drawn up by a competent person following manufacturer's guidelines;
  - (iii) after use in an arduous environment;
  - (iv) after an occurrence of exceptional circumstances liable to jeopardize the safety of the equipment;
- 2) that it functions correctly and is safe to use;
- h) in relation to every detailed inspection, with reference to the previous detailed inspection report(s):
- 1) identification of any part found to have a defect which is or could become a danger to persons;
  - 2) particulars of any repair, renewal or alteration required to remedy a defect found to be a danger to persons;
  - 3) in the case of a defect which is not yet but could become a danger to persons:
    - (i) instructions to rope access technicians and rope access supervisors to monitor the defect closely during the pre-use check;
    - (ii) details of any repair, renewal or alteration required to remedy it;
    - (iii) the latest date by which the next detailed inspection has to be carried out. (In the case of equipment that has a defect which is not yet but could become a danger, detailed inspections might be more frequent than normal.);
    - (iv) where the detailed examination included testing, details of any test;
    - (v) the date of the detailed inspection;
- i) the name, address and competency (e.g. having attended and passed a relevant manufacturer's training course) of the person making the report; that he/she is self-employed or, if employed, the name and address of the employer;
- j) the name and address of a person signing or authenticating the report on behalf of its author;
- k) the date of the report.



**IRATA International code of practice  
for industrial rope access**

**Part 3: Informative annexes**

**Annex J: Resistance to chemicals and other  
properties of some of the man-made fibres used in  
the manufacture of rope access equipment**

**September 2013**

The first edition of Annex J was published in December 2010.  
This edition was published in March 2013.

Amendments issued since publication in March 2013

Amd. No	Date	Text affected
1	2013-Sep-01	Front cover: <i>September 2013</i> replaces <i>2013 edition</i> . This page: change of IRATA address and telephone number. Date in footer updated. All the changes are classed as editorial.

Published by:

IRATA International  
First Floor, Unit 3  
Eurogate Business Park  
Ashford  
Kent  
TN24 8XW  
England

Tel: +44 (0)1233 754600

Email: [info@irata.org](mailto:info@irata.org)

Website: [www.irata.org](http://www.irata.org)

Copyright © IRATA International 2013

ISBN: 978-0-9544993-5-8

## **Annex J (informative)**

### **Resistance to chemicals and other properties of some of the man-made fibres used in the manufacture of rope access equipment**

#### **Introduction**

Annex J gives advice and other information that could be relevant to users of rope access methods and is one of a number of informative annexes in Part 3 of this code of practice. This informative annex should be read in conjunction with other parts of this code of practice, should not be used in isolation and is not intended to be exhaustive. For further advice, readers should refer to relevant specialist publications.

#### **J.1 General**

**J.1.1** The resistance to chemicals of some of the man-made fibres used in the manufacture of rope access equipment is given in **Table J.1** and other properties are given in **Table J.2**. This information has been compiled from manufacturers' data. It should be noted that several variants of most of these fibres exist and new variants are continually being developed.

**J.1.2** The information in this annex may be used in the risk assessment process, prior to work commencing, to ensure the performance of equipment will not be adversely affected by chemicals to a point where the safety of the user is compromised.

**J.1.3** Some contaminants found on the worksite may be a complex mixture of several of the chemicals listed. This should be taken into account when planning the work. More specific information about the chemicals may be required, e.g. the effect of variations in temperature and concentration.

**J.1.4** It is strongly recommended that before working in an area where chemical contaminants are suspected, the manufacturer of the equipment or his authorised representative is consulted with regard to the properties of the safety-critical materials used in the equipment's manufacture, bearing in mind that more than one type of man-made fibre could have been utilised, e.g. polyamide and polyester.

**Table J.1 — Resistance to chemicals of some of the man-made fibres used in the manufacture of rope access equipment (page 1 of 6)**

Chemical	Aramid			Polyamide <sup>a</sup> (PA)		Polyester <sup>a</sup> (PET)		High performance polyethylene (HPPE)	Polypropylene <sup>b</sup> (PP)		High tenacity polypropylene (HTPP)
	21 °C <sup>c</sup>	60 °C	20 °C 6 months	6 months <sup>d</sup>	60 °C	20 °C	60 °C	6 months <sup>d</sup>	4 days 20 °C	21 h 70 °C	6 months <sup>d</sup>
Acetic acid 10 %	OK	!	OK	OK	!	OK	OK	OK	OK	!	OK
50 %	! (1 000h)	!	OK	OK	☠	OK	OK	OK	OK	!	OK
80 %	OK	☠	OK	OK	☠	OK	OK	OK	OK	!	OK
100 %	OK (24h)	☠	!	OK	☠	!	☠	OK	!	!	OK
Acetic acid (glacial)	?	?	?	OK	?	?	?	OK	?	?	OK
Acetone	OK	OK	!	OK	OK	!	☠	OK	OK	!	OK
Ammonia gas	?	?	!	OK	?	!	☠	OK	OK	OK	OK
Ammonia solution 10 %	OK	!	☠	OK	!	☠	☠	OK	OK	OK	OK
25 %	OK	☠	☠	OK	☠	☠		OK	OK	OK	OK
100%	OK	☠	☠	OK	☠	☠	☠	OK	OK	OK	OK
Aniline	?	!	?	OK	!	?	?	OK	OK	OK	OK
Aqua regia	?	☠	☠	☠	☠	☠	☠	☠	☠	☠	☠
Aviation fuel (115/145 octane)	OK	OK	OK	OK	OK	OK	OK	OK	!	☠	OK
Aviation fuel (turbine fuel)	OK	OK	OK	OK	OK	OK	OK	OK	!	☠	OK
Benzene	OK	OK	OK	OK	OK	OK	!	OK	?	☠	OK
Brine (saturated)	!	OK	OK	OK	!	OK	!	OK	OK	OK	OK

**Key**

**OK** Negligible effect; **!** Limited effect (Caution!); **☠** Considerable effect (Danger!); **?** No information available.

<sup>a</sup> Test duration not known.

<sup>b</sup> Except for high tenacity polypropylene.

<sup>c</sup> Values in parentheses are test durations. The test duration for other chemicals is not known.

<sup>d</sup> Test temperature not known (probably 20 °C).

**Table J.1 — Resistance to chemicals of some of the man-made fibres used in the manufacture of rope access equipment (page 2 of 6)**

Chemical	Aramid			Polyamide <sup>a</sup> (PA)		Polyester <sup>a</sup> (PET)		High performance polyethylene (HPPE)	Polypropylene <sup>b</sup> (PP)		High tenacity polypropylene (HTPP)
	21 °C <sup>c</sup>	60 °C	20 °C 6 months	6 months <sup>d</sup>	60 °C	20 °C	60 °C	6 months <sup>d</sup>	4 days 20 °C	21 h 70 °C	6 months <sup>d</sup>
Bromine gas	?	?	!	!	?	!	☠	!	☠	☠	!
Calcium hypochlorite 20 %	?	?	?	☠	☠	!	!	!	!	!	!
Carbon dioxide gas	?	?	?	!	!	OK	OK	OK	OK	OK	OK
Carbon tetrachloride	OK	OK	?	OK	OK	OK	OK	OK	☠	☠	OK
Castor oil	?	?	?	OK	OK	OK	!	OK	OK	OK	OK
Chlorine gas	?	?	?	☠	☠	?	?	☠	☠	☠	☠
Chlorine water	?	?	?	OK	!	OK	OK	☠	OK	!	☠
Chloroform	!	☠	?	!	!	!	!	OK	☠	☠	OK
Chromic acid 1 %	?	?	?	☠	☠	!	☠	☠	!	!	☠
10 %	☠	?	?	?	?	?	?	?	?	!	?
50 %	?	?	?	☠	☠	☠	☠	☠	!	!	☠
80 %	?	?	?	☠	☠	☠	☠	☠	?	?	☠
Dibutyl phthalate	?	?	?	OK	?	OK	?	OK	OK	!	OK
Diethyl ether	?	?	?	OK	?	OK	?	OK	!	?	OK
Ethylene glycol	?	?	?	OK	?	OK	?	OK	OK	OK	OK
Freon	OK	OK 500h	?	OK	?	OK	?	OK	OK	?	OK
Formic acid 40 %	! 10 000 h	?	?	?	?	?	?	?	?	?	?
75 %	OK 100 h	?	?	?	?	OK	!	OK	?	?	OK

**Key**

**OK** Negligible effect; **!** Limited effect (Caution!); **☠** Considerable effect (Danger!); **?** No information available.

<sup>a</sup> Test duration not known.

<sup>b</sup> Except for high tenacity polypropylene.

<sup>c</sup> Values in parentheses are test durations. The test duration for other chemicals is not known.

<sup>d</sup> Test temperature not known (probably 20 °C).

**Table J.1 — Resistance to chemicals of some of the man-made fibres used in the manufacture of rope access equipment (page 3 of 6)**

Chemical	Aramid			Polyamide <sup>a</sup> (PA)		Polyester <sup>a</sup> (PET)		High performance polyethylene (HPPE)	Polypropylene <sup>b</sup> (PP)		High tenacity polypropylene (HTPP)
	21 °C <sup>c</sup>	60 °C	20 °C 6 months	6 months <sup>d</sup>	60 °C	20 °C	60 °C	6 months <sup>d</sup>	4 days 20 °C	21 h 70 °C	6 months <sup>d</sup>
Glycerine	?	?	?	OK	OK	OK	OK	OK	OK	OK	OK
Hydrochloric acid 2 %	!	☠	☠	!	☠	!	!	OK	OK	OK	OK
Hydrochloric acid 10 %	☠ (100h)	☠	?	☠	☠	!	!	OK	OK	OK	OK
30 %	☠	☠	?	☠	☠	!	☠	OK	OK	OK	OK
38 % (concentrated)	☠	☠	?	☠	☠	☠	☠	OK	OK	!	OK
Hydrofluoric acid 2 %	OK	!	?	☠	☠	OK	!	!	OK	OK	!
10 %	OK (100 h)	☠	?	☠	☠	☠	☠	OK	OK	OK	OK
20 %	☠	☠	?	☠	☠	☠	☠	OK	OK	OK	OK
Hydrogen peroxide 1 %	?	?	?	☠	☠	OK	OK	!	OK	OK	!
3 %	?	?	?	☠	☠	!	☠	!	OK	!	!
10 %	?	?	?	☠	☠	!	☠	?	OK	!	?
30 %	?	?	?	☠	☠	!	☠	?	OK	☠	?
12 part	?	?	?	?	?	?	?	?	?	?	?
Hydrogen sulphide	?	?	?	OK	!	!	!	?	OK	OK	?
Kerosene	OK	OK (500 h)	OK	?	?	?	?	OK	!	☠	OK
Lactic acid 20 %	?	?	?	!	☠	OK	OK	OK	OK	OK	OK
Lanolin	?	?	?	OK	OK	OK	OK	OK	OK	OK	OK
Lubricating oil	?	?	?	OK	OK	OK	OK	OK	OK	!	OK

**Key**

**OK** Negligible effect; **!** Limited effect (Caution!); **☠** Considerable effect (Danger!); **?** No information available.

<sup>a</sup> Test duration not known.

<sup>b</sup> Except for high tenacity polypropylene.

<sup>c</sup> Values in parentheses are test durations. The test duration for other chemicals is not known.

<sup>d</sup> Test temperature not known (probably 20 °C).



**Table J.1 — Resistance to chemicals of some of the man-made fibres used in the manufacture of rope access equipment (page 4 of 6)**

Chemical	Aramid			Polyamide <sup>a</sup> (PA)		Polyester <sup>a</sup> (PET)		High performance polyethylene (HPPE)	Polypropylene <sup>b</sup> (PP)		High tenacity polypropylene (HTPP)
	21 °C <sup>c</sup>	60 °C	20 °C 6 months	6 months <sup>d</sup>	60 °C	20 °C	60 °C	6 months <sup>d</sup>	4 days 20 °C	21 h 70 °C	6 months <sup>d</sup>
Meat juices	?	?	?	OK	OK	OK	OK	OK	OK	OK	OK
Methanol	!	!	?	OK	!	OK	OK	OK	OK	OK	OK
Methyl ethyl ketone	OK	OK	?	OK	?	OK	?	OK	OK	☠	OK
Motor oil	OK	OK (10 h)	?	OK	OK	OK	OK	OK	!	☠	OK
Naphthalene	OK	OK	?	OK	?	OK	!	OK	OK	OK	OK
Nitric acid 10 %	☠ (100 h)	☠	☠	☠	☠	OK	!	OK	OK	!	OK
50 %	☠	☠	?	☠	☠	!	☠	OK	☠	☠	OK
70 %	☠ (24 h)	☠	?	☠	☠	☠	☠	☠	?	☠	☠
fuming	?	?	?	☠	☠	☠	☠	☠	☠	☠	☠
Nitrobenzene	?	?	?	☠	☠	☠	☠	OK	!	?	OK
Petrol	?	?	OK	?	?	?	?	OK	?	?	OK
Perchloroethylene	OK	OK (10 h)	OK	OK	OK	OK	OK	OK	?	?	OK
Phosphoric acid 25 %	OK	OK	?	☠	☠	!	☠	OK	OK	?	OK
50 %	!	!	?	☠	☠	☠	☠	OK	OK	?	OK
Phenol 5 %	OK	?	?	☠	☠	!	☠	?	☠	?	?
Phenol based disinfectant	?	?	?	?	?	?	?	?	OK	!	?

**Key**

**OK** Negligible effect; **!** Limited effect (Caution!); **☠** Considerable effect (Danger!); **?** No information available.

<sup>a</sup> Test duration not known.

<sup>b</sup> Except for high tenacity polypropylene.

<sup>c</sup> Values in parentheses are test durations. The test duration for other chemicals is not known.

<sup>d</sup> Test temperature not known (probably 20 °C).

**Table J.1 — Resistance to chemicals of some of the man-made fibres used in the manufacture of rope access equipment (page 5 of 6)**

Chemical	Aramid			Polyamide <sup>a</sup> (PA)		Polyester <sup>a</sup> (PET)		High performance polyethylene (HPPE)	Polypropylene <sup>b</sup> (PP)		High tenacity polypropylene (HTPP)
	21 °C <sup>c</sup>	60 °C	20 °C 6 months	6 months <sup>d</sup>	60 °C	20 °C	60 °C	6 months <sup>d</sup>	4 days 20 °C	21 h 70 °C	6 months <sup>d</sup>
Potassium hydrate 40 %	?	?	?	?	?	?	?	?	?	?	?
Sea water	?	?	OK	?	?	?	?	OK	?	?	OK
Silicone oil	?	?	?	OK	OK	OK	OK	OK	OK	OK	OK
Sodium hydrate 40 %	?	?	?	?	?	?	?	?	?	?	?
Sodium hydroxide 10 %	!	☠	☠	OK	OK	!	☠	!	OK	OK	!
50 %	?	?	?	!	☠	☠	☠	?	OK	OK	?
Sodium hypochlorite (0.25 % Cl)	?	?	?	?	?	OK	OK	!	?	?	!
(5 % Cl)	☠ (1 000 h)	?	?	?	?	OK	OK	?	?	?	?
Sulphuric acid 2 %	OK (1 000 h)	!	?	!	!	!	☠	OK	OK	OK	OK
10 %	! (1 000 h)	☠	?	☠	☠	!	☠	OK	OK	OK	OK
50 %	☠	☠	?	☠	☠	!	☠	!	OK	!	!
90 %	☠	☠	?	☠	☠	☠	☠	☠	OK	?	☠
Sulphur dioxide	?	?	?	☠	☠	!	☠	?	OK	OK	?
Tallow	?	?	?	OK	OK	OK	OK	?	OK	OK	?
Toluene	OK	OK	!	OK	OK	OK	OK	OK	?	☠	OK

**Key**

**OK** Negligible effect; **!** Limited effect (Caution!); **☠** Considerable effect (Danger!); **?** No information available.

<sup>a</sup> Test duration not known.

<sup>b</sup> Except for high tenacity polypropylene.

<sup>c</sup> Values in parentheses are test durations. The test duration for other chemicals is not known.

<sup>d</sup> Test temperature not known (probably 20 °C).

**Table J.1 —Resistance to chemicals of some of the man-made fibres used in the manufacture of rope access equipment (page 6 of 6)**

Chemical	Aramid			Polyamide <sup>a</sup>		Polyester <sup>a</sup>		High performance polyethylene (HPPE)	Polypropylene <sup>b</sup> (PP)		High tenacity polypropylene (HTPP)
	21 °C <sup>c</sup>	60 °C	20 °C 6 mth	6 months <sup>d</sup>	60 °C	20 °C	60 °C		6 months <sup>d</sup>	4 days 20 °C	
Transformer oil	OK	OK	?	OK	OK	OK	OK	OK	OK	☠	OK
Trichloroethylene	OK	OK	?	OK	OK	OK	OK	OK	?	☠	OK
Turpentine	?	?	?	OK	OK	OK	OK	OK	☠	☠	OK
Urine	?	?	?	OK	!	OK	OK	?	OK	OK	?
White spirit	OK	!	?	OK	OK	OK	OK	OK	☠	☠	OK
Xylene	?	?	?	OK	OK	OK	OK	OK	☠	☠	?

**Key**

OK Negligible effect; ! Limited effect (Caution!); ☠ Considerable effect (Danger!); ? No data: effects not known.

<sup>a</sup> Test duration not known.

<sup>b</sup> Except for high tenacity polypropylene.

<sup>c</sup> Values in parentheses are test durations. The test duration for other chemicals is not known.

<sup>d</sup> Test temperature not known (probably 20 °C).

**Table J.2 — Other properties of some of the man-made fibres used in the manufacture of rope access equipment**

Property	Aramid	Polyamide (PA)		Polyester (PET)	High performance polyethylene (HPPE)	High tenacity polypropylene (HTPP)
		Type 6	Type 66			
Melting point (°C)	Chars at 350 <sup>a</sup>	195 to 230	235 to 260	230 to 260	145 to 155	165 to 170
Effect of low temperature (-40 °C)	Nil	Nil	Nil	Nil	Nil	Nil
Abrasion resistance	Poor	Very good	Very good	Very good	Good	Fair
Flexion durability	Very poor	Very good	Very good	Very good	Good	Good
Moisture regain (%) <sup>c</sup>	4 to 8	4.5	4.5	0.4	<0.05	0.05
Loss of strength when wet (%)	Nil	10 to 20	10 to 20	Nil	?	Nil
Resistance to UV	Poor	Poor	Good	Good	Good	Good <sup>b</sup>
Density (g/cm <sup>3</sup> )	1.44	1.12	1.14	1.38	0.97	0.91
Tensile strength (GPa)	3.4	?	0.9	1.1	2.7	0.6
Tenacity (N/tex)	1.9	0.7	0.8	0.8	2.65	0.6 - 0.7
Tenacity (g/den)	23	8	9	9	30	7.0 - 7.5
Elongation at break (%)	2.4 to 3.6	20	20	13	3.5	18
Comments	Fire resistant	—	—	—	Floats on water	Floats on water

**Key**

? No information available.

— No comment

<sup>a</sup> Aramids do not melt but decompose at 427 °C to 482 °C.

<sup>b</sup> Good with inhibitor but poor without.

<sup>c</sup> The mass of the fibres increases through absorption of moisture; in this case, ambient atmospheric moisture.



**IRATA International code of practice  
for industrial rope access**

**Part 3: Informative annexes**

**Annex K: Typical method of descending and  
ascending using IRATA International rope access**

**September 2013**

The first edition of Annex K was published in January 2010.  
This edition was published in March 2013.

Amendments issued since publication in March 2013

Amd. No	Date	Text affected
1	2013-Sep-01	Front cover: <i>September 2013</i> replaces <i>2013 edition</i> . This page: change of IRATA address and telephone number. Date in footer updated. All the changes are classed as editorial.

Published by:

IRATA International  
First Floor, Unit 3  
Eurogate Business Park  
Ashford  
Kent  
TN24 8XW  
England

Tel: +44 (0)1233 754600

Email: [info@irata.org](mailto:info@irata.org)

Website: [www.irata.org](http://www.irata.org)

Copyright © IRATA International 2013

ISBN: 978-0-9544993-5-8

## **Annex K (informative)**

### **Typical method of descending and ascending using IRATA International rope access techniques**

#### **Introduction**

Annex K gives advice and other information that could be relevant to users of rope access methods and is one of a number of informative annexes in Part 3 of this code of practice. This informative annex should be read in conjunction with other parts of this code of practice, should not be used in isolation and is not intended to be exhaustive. For further advice, readers should refer to relevant specialist publications.

#### **K.1 Pre-use equipment check**

**K.1.1** All equipment in the rope access system should be checked before use to ensure it is in good condition and functions correctly. Suspect items should be taken out of service.

**K.1.2** Before approaching the point of descent or ascent, or commencing to descend or ascend, checks should be made to ensure:

- a) harnesses and helmets are correctly fastened and adjusted;
- b) lanyards and connectors are correctly fastened;
- c) anchors are appropriate and secure;
- d) working lines and safety lines are the correct length for the task, are anchored correctly and are free from damage;
- e) stopper knots are tied at the lower end of both the working line and the safety line at an appropriate position, with an allowance for stretch;
- f) tools or other items are secured so they cannot fall.

*NOTE* The checks in a) and b) are usually best carried out by a co-worker. This is known as a buddy check.

**K.1.3** Additional checks should be made to ensure:

- a) anchor lines are rigged so as to avoid being damaged during the work operation;
- b) anchor line devices are attached to the anchor lines correctly.

#### **K.2 Use of the back-up device**

The back-up device, which is connected to the safety line, is used to protect against falls before, during and after attachment of the rope access technician to the working line. It should be the first item to be attached to the anchor lines, i.e. before ascending or descending devices, and the last item to be removed at the point of egress, i.e. after removing the descending device or ascending devices. The back-up device should be managed at all times in such a way that the potential fall distance is minimized.

### **K.3 Descending and ascending**

*NOTE Care should be taken to eliminate any slack in the anchor lines before commencing a descent or ascent. Examples of when slack can occur inadvertently are: if the anchor is positioned some distance from the point of loading; when a rope access technician unloads the working line halfway down a descent; if the working line becomes accidentally snagged between the anchor and point of access.*

#### **K.3.1 Method for descending (see Figure K.1)**

*NOTE Combinations of equipment other than that shown in Figure K.1 may be suitable.*

**K.3.1.1** Approach the point of descent with care, using an additional fall protection system if necessary, e.g. an anchor lanyard attached to an anchor, taking into account the precautions detailed in **K.1**, **K.2** and the note to **K.3**. Check that all anchor line devices, device lanyards and connectors are attached to the harness correctly and that they function correctly.

**K.3.1.2** Place the back-up device on the safety line and:

- a) check that the back-up device attachment connector is correctly closed and locked;
- b) check for correct attachment and orientation of the back-up device on the safety line (e.g. that it is not upside down);
- c) ensure there is no slack in the anchor line above the device (to minimise any potential fall);
- d) carry out a function check, e.g. check that the back-up device locks on the anchor line.

**K.3.1.3** Adjacent to the point of descent, fit the descending device onto the working line. Prior to beginning the descent, check that it is fitted correctly, e.g. that:

- a) the connector used to attach the descending device to the harness is correctly closed and locked;
- b) the working line is correctly threaded into the descending device;
- c) where present, safety catches are fully closed;
- d) the descending device is locked correctly on to the working line.

**K.3.1.4** Take a position ready for descent, which may be in tension, e.g. connected to an anchor by an anchor lanyard (not shown in **Figure K.1**), or unsupported, depending on the take-off point. Carry out a function test as follows:

- a) with either the back-up device in a high 'hands off position' on the safety line or with an anchor lanyard attached to an anchor to provide protection, unlock the descending device while keeping a secure grip on the working line beneath the descending device;
- b) carry out a controlled descent of approximately 150 to 200 mm to confirm the descending device is functioning correctly. If an anchor lanyard is used for protection, it should then be removed.

**K.3.1.5** Descend carefully and slowly, controlling the speed of descent by means of the descending device, the precise method depending on the type of descending device used. Never lose control of the free end (the tail) of the working line leaving the descending device. Always lock the descending device to the working line during stops in the descent. Where the back-up device is used with a device lanyard, ensure it is managed so that there is minimum slack in the device lanyard.

**K.3.1.6** If, during the descent, the descending device is removed and reinstalled on the working line, check the descending device is locked correctly on to the working line and carry out the function test described in **K.3.1.4** before continuing the descent. A function test should be carried out at other times, e.g. after passing an obstruction, if the descending device has been unweighted, when environmental conditions change such as from dry to wet, muddy or icy.



**K.3.1.7** When the working position is reached, lock the descending device and position the back-up device as high as possible. Before recommencing the descent, check the descending device is locked correctly on to the working line and carry out the function test described in **K.3.1.4**.

### **K.3.2 Method for ascending (see Figure K.2)**

*NOTE* Combinations of equipment other than that shown in Figure K.2 may be suitable.

**K.3.2.1** Approach the point of ascent with care, using an additional fall protection system if necessary, e.g. an anchor lanyard attached to an anchor, taking into account the precautions detailed in **K.1**, **K.2** and the note to **K.3**. Check that anchor line devices, device lanyards and connectors are attached to the harness correctly and that they function correctly.

**K.3.2.2** Place the back-up device on the safety line at shoulder height. Carry out a function test as described in **K.3.1.2**. Fit the other anchor line, i.e. the working line, to the chest ascending device, and take the initial stretch out of it by pulling it down through the chest ascending device. In addition to taking up the stretch, this acts as a function test. Fit the foot ascending device to the working line above the chest ascending device. By standing in the foot loop, pull through any further slack in the working line, passing the slack through the chest ascending device until the working line is as taut as possible.

**K.3.2.3** To begin the ascent, load the body weight on to the chest ascending device and lift the foot ascending device to approximately top-of-the-head height. Stand up in the foot loop and pull the resulting slack through the chest ascending device as before. Sit down, so the load is again taken on the chest ascending device, and repeat this process until the ascent is completed.

**K.3.2.4** During the ascent, manage the back-up device in such a way that slack is minimized in the device lanyard (where used) and in the safety line. On reaching the top of the climb, attach to a secure anchor or safety system, e.g. by using an anchor lanyard (not shown in **Figure K.2**). Remove the chest ascending device from the working line first, then the foot ascending device. When a safe place has been reached, remove the back-up device.

*NOTE* It is essential that ascending devices are only used in tension on the anchor line and that they are not used in such a way that they could be subjected to a dynamic load, e.g. the force of a fall.

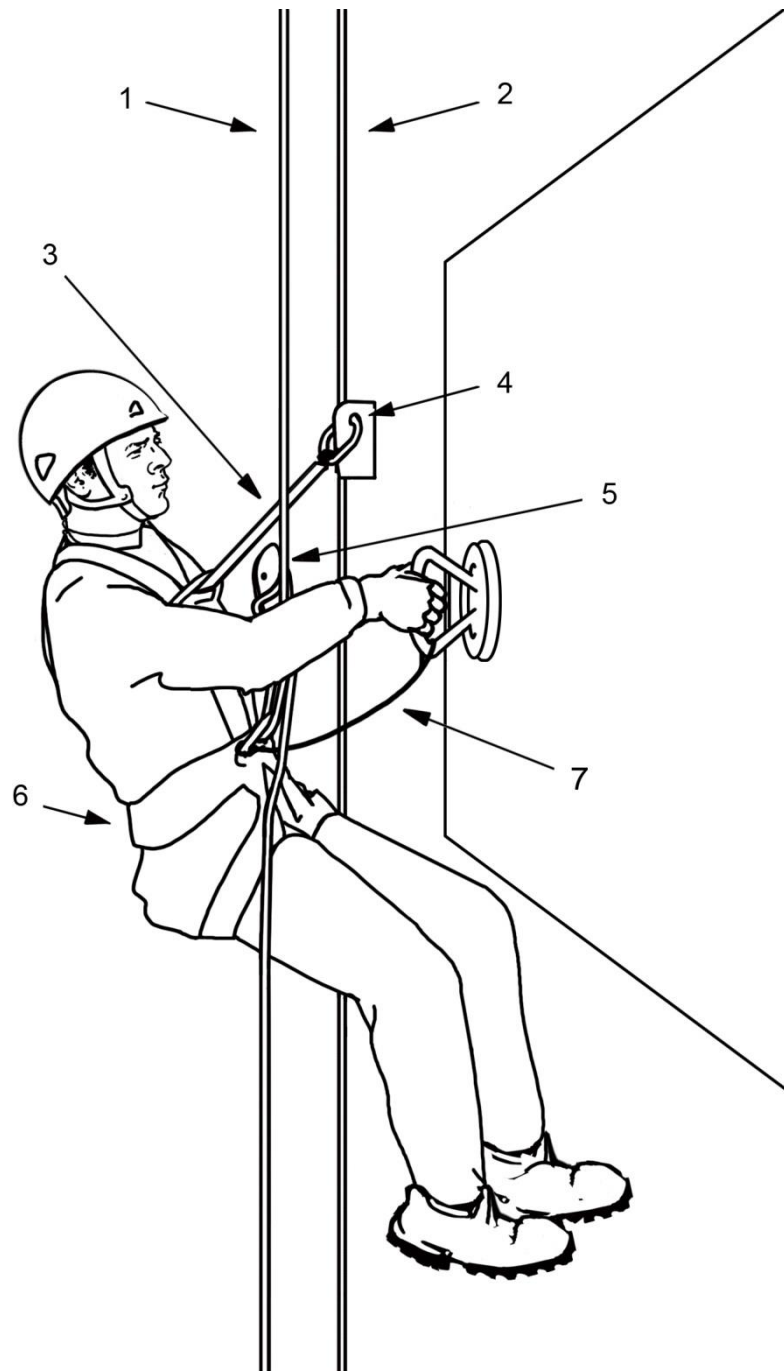

**Key**

- |                  |                     |
|------------------|---------------------|
| 1 Working line   | 5 Descending device |
| 2 Safety line    | 6 Harness           |
| 3 Device lanyard | 7 Tool tether       |
| 4 Back-up device |                     |

**Figure K.1 — Typical method of working in the descent mode in a rope access system (with descending device locked)**

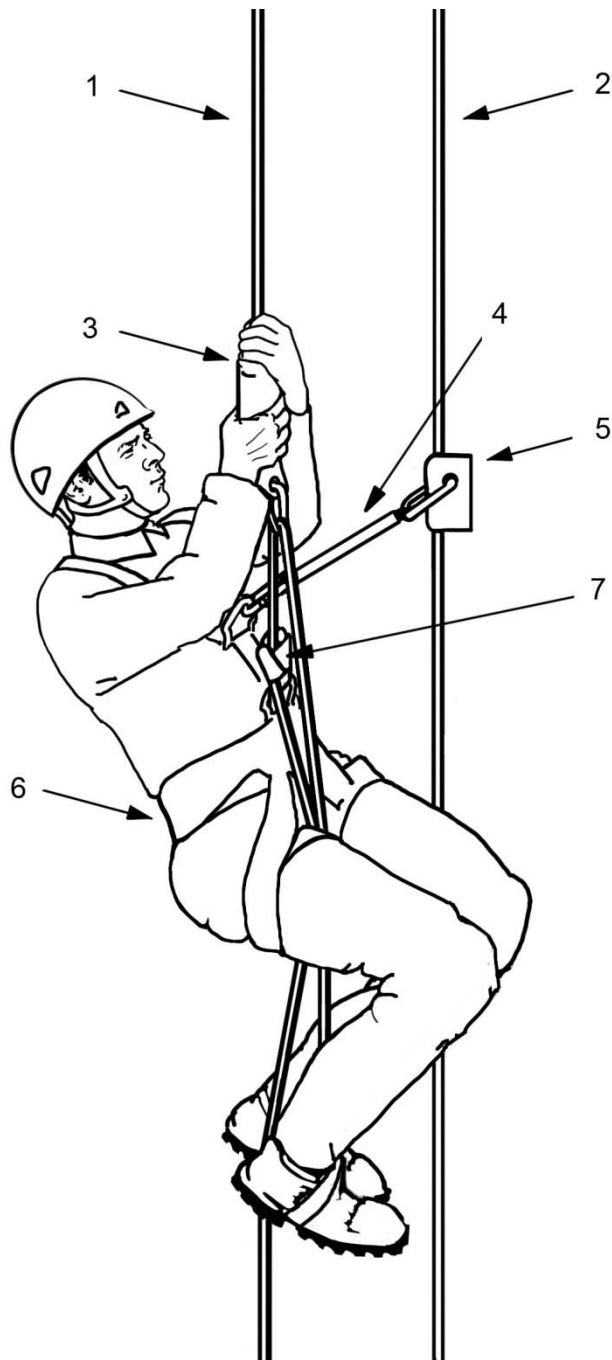

**Key**

- |                                     |                            |
|-------------------------------------|----------------------------|
| 1 Working line                      | 5 Back-up device           |
| 2 Safety line                       | 6 Harness                  |
| 3 Ascending device (with foot loop) | 7 Ascending device (chest) |
| 4 Device lanyard                    |                            |

**Figure K.2 — Typical method of ascending in a rope access system**



**IRATA International code of practice  
for industrial rope access**

**Part 3: Informative annexes**

**Annex L: Other harness-based work at height  
access methods**

**August 2014**

The first edition of Annex L was published in July 2010.  
This edition was published in October 2013

#### Amendments issued since publication

Amd. No	Date	Text affected
1	2014-Aug-01	Front cover: dated changed to August 2014. Introduction: <i>Title of publication referred to corrected to IRATA International training, assessment and certification scheme for personnel engaged in industrial rope access methods (TACS).</i> Footer: date changed to 2014-Aug-01.

Published by:

IRATA International  
First Floor, Unit 3  
Eurogate Business Park  
Ashford  
Kent  
TN24 8XW  
England

Tel: +44 (0)1233 754600

Email: [info@irata.org](mailto:info@irata.org)

Website: [www.irata.org](http://www.irata.org)

Copyright © IRATA International 2013

ISBN: 978-0-9544993-5-8

## Annex L (informative)

### Other harness-based work at height access methods

#### Introduction

Annex L gives advice and other information that could be relevant to users of rope access methods and is one of a number of informative annexes in Part 3 of this code of practice. This informative annex should be read in conjunction with other parts of this code of practice, should not be used in isolation and is not intended to be exhaustive. For further advice, readers should refer to relevant specialist publications.

Some of the systems, methods and techniques covered in this informative annex are not currently within the scope of the *IRATA International training, assessment and certification scheme for personnel engaged in industrial rope access methods (TACS)*. They are, however, sometimes used in conjunction with normal rope access activities.

It should be noted that:

- this informative annex does not cover the training required for the the various harness-based personal fall protection systems, methods and techniques described;
- no guidance is given on the appropriate and safe means of transition between a rope access system and these other harness-based personal fall protection systems.

#### L.1 General

**L.1.1** Clause **L.2** provides information on various harness-based personal fall protection systems that may be used to access worksites at height and gives advice on some of the equipment commonly used in these systems. Clause **L.3** provides information and advice on climbing techniques sometimes used to gain access to worksites.

**L.1.2** Methods and techniques provided during IRATA International rope access training and certification should not be taken as a suitable standalone qualification to prove the user's competence in the harness-based personal fall protection systems and climbing techniques described in clauses **L.2** and **L.3**.

**L.1.3** Employers should ensure that personnel using these harness-based personal fall protection systems, methods and climbing techniques are competent in their use, including emergency applications, and have received training, where appropriate. The information supplied by the manufacturer for any equipment used in these systems, methods and techniques should be followed. Before use, it should be checked that the chosen harness-based personal fall protection systems or climbing techniques are suitable for the particular task in hand.

#### L.2 Harness-based personal fall protection systems

##### L.2.1 General

**L.2.1.1** There are five recognized harness-based personal fall protection systems. These are work restraint, rope access, work positioning, fall arrest and rescue. The first four of these personal fall protection systems can be used for access when working at height. Each has its own set of requirements or rules. It should be noted that rope access is a type of work positioning system but, because of its developed techniques and use in special circumstances, it has its own category of personal fall protection system. Rope access and rescue are not covered in this annex. For general information on personal fall protection systems and the selection of equipment, see **Part 2, 2.7.1**.

**L.2.1.2** Harness-based personal fall protection systems comprise at least:

- a) a harness (body holding device) appropriate to the personal fall protection system being used;
- b) an anchor or anchors fitted to the structure or natural feature, which should be unquestionably reliable;
- c) connecting components, e.g. anchor lines; lanyards; energy absorbers; fall arresters; connectors, to link the user via the harness to the anchor.

**L.2.1.3** All components in a personal fall protection system should be safety compatible, i.e. the safe function of any one component should not interfere with the safe function of another.

**L.2.1.4** For more information on anchors, on the protection of anchor lines and on the selection of equipment, see **Part 2** and **Part 3, Annexes F and P**.

## **L.2.2 Work restraint (travel restriction) systems**

Work restraint systems are used to stop a person from reaching zones where the risk of a fall exists, e.g. by the user being connected to an anchor or a horizontal anchor line by a lanyard of such a length that they are prevented from reaching the unprotected edge of a building. The moment a position is reached where a fall from a height could occur or where the user has to rely on support by the system, the system can no longer be considered a work restraint system and other appropriate fall protection measures should be taken. More information is given in **Part 2, 2.7.1.5** and **2.7.1.6**. For information on restraint lanyards, see **Annex E**.

## **L.2.3 Work positioning systems**

### **L.2.3.1 General**

**L.2.3.1.1** Work positioning systems are used to:

- a) allow access to the workplace, egress from it and to support the user, either partially or fully, at the place of work;
- b) protect the user against a fall from a height.

**L.2.3.1.2** Depending on their design, work positioning systems may be used in vertical, diagonal and horizontal planes. For fundamental information on work positioning systems, see **Part 2, 2.7.1.5**.

**L.2.3.1.3** A work positioning system should incorporate a safety back-up fall protection system, in case there is a fall. In some jurisdictions, this is a legal requirement.

**L.2.3.1.4** Work positioning systems should be set up and used in such a way that they do not allow a fall to occur. However, even with the best efforts, this may not always be possible so, in the worst case, they should prevent anything more than a very short fall with a low impact load. The consequence of any potential fall should be minimized.

**L.2.3.1.5** There are at least two commonly-used work positioning methods. These are described in **L.2.3.2** and **L.2.3.3**.

### **L.2.3.2 Work positioning method 1**

**L.2.3.2.1** This method of work positioning is used on relatively steep or slippery sloping surfaces, e.g. a roof or a steep concrete or grassy banking. It utilizes an anchor line (which, in work positioning systems is sometimes referred to as a work positioning lanyard), which is attached to an anchor point above the user. In non-adjustable systems, the user is connected directly to the anchor line, e.g. by a fixed loop termination in the anchor line, which is connected to an appropriate attachment point on the user's harness. In adjustable systems, an adjustment device is connected to the anchor line and to the user's harness (see **Figure L.1**). The adjustment device allows the user to vary their position on the anchor line. With the feet or knees braced against the sloping surface, the user is able to lean backwards to attain a partially supported position, leaving the hands free to carry out the work.

**L.2.3.2.2** In addition, a separate safety back-up fall protection system with its own independent anchor point is utilized, e.g. a fall arrest system based on a guided type fall arrester and a flexible anchor line, using the fall arrest attachment point on the user's full body harness. The arrangement should be established and kept in such a way that the distance and consequence of any fall are minimized, e.g. there should be a minimum of slack in the anchor line and lanyards.

**L.2.3.2.3** This work positioning method is not a rope access personal fall protection system. Qualified rope access technicians are recommended to adopt rope access equipment, procedures and techniques in place of this method of work positioning.

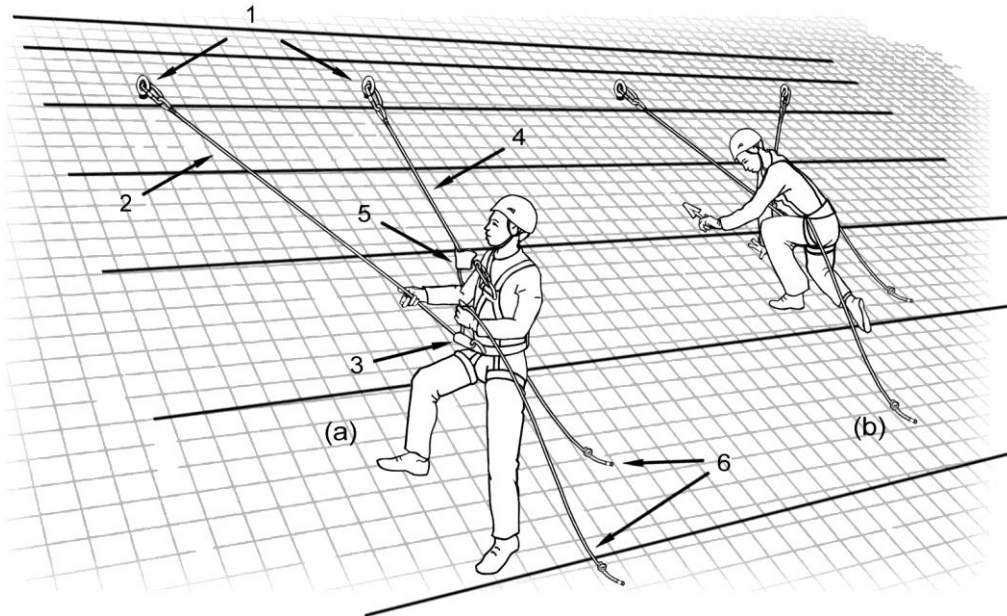

**Key**

- (a) Adjusting the length of the anchor line used as an adjustable work positioning lanyard
- (b) Worker supported by the anchor line being used as an adjustable work positioning lanyard

- 1 Anchor
- 2 Anchor line for work positioning and support (adjustable work positioning lanyard)
- 3 Adjustment device
- 4 Anchor line for safety back-up system
- 5 Fall arrest device
- 6 Spare length of anchor line with stopper knot or stopper device fitted

**Figure L.1 – Example of a work positioning system for use on steep or slippery surfaces (work positioning method 1)**

**L.2.3.3 Work positioning method 2**

**L.2.3.3.1** A popular method of work positioning on structures such as telegraph poles, electricity poles, masts and towers uses a special work positioning lanyard, sometimes referred to as a *pole strap*. This is passed around the structure and connected to the harness, typically to two side waist attachment points or to a central attachment point at approximately waist level. The work positioning lanyard is usually adjustable.

**L.2.3.3.2** With the feet braced against the structure, the user is able to lean backwards to attain a partially supported position, leaving the hands free to carry out the work. In addition, a separate safety back-up fall protection system is attached to the structure. See **Figure L.2**.

**L.2.3.3.3** The place at which the work positioning lanyard is attached to the structure is usually attained by climbing some type of ladder. However, it is also possible to use a double or triple lanyard



system (see **L.3.2**) to climb the structure in any direction, as long as the lanyards are attached to the structure for each move in such a way that a fall cannot occur.

**L.2.3.3.4** The work positioning lanyard should not be used without the separate safety back-up fall protection system because, should a fall occur, the work positioning lanyard might not stay in place around the structure, thus increasing the fall distance, and the energy absorption capacity might not be sufficient to keep any impact loads to an acceptable level.

**L.2.3.3.5** The safety back-up system typically comprises an anchor sling attached to the structure above the user and connected to an appropriate energy-absorbing lanyard, which is attached to the fall arrest attachment point on the full body harness. The arrangement should be established and kept in such a way that the distance and consequence of any fall are minimized, e.g. there should be a minimum amount of slack in the lanyards.

**L.2.3.3.6** For more information on work positioning lanyards, see **Annex E**.

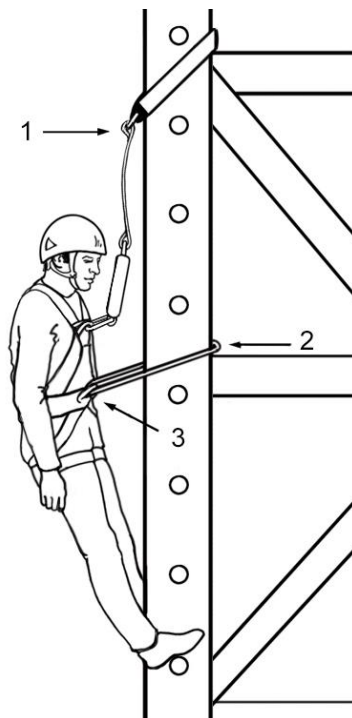

#### Key

- 1 Safety back-up (in this example, an energy-absorbing fall arrest lanyard linked to an anchor sling)
- 2 Work positioning lanyard passed around the structure
- 3 Work positioning lanyard attached to the work positioning attachment point on the harness (could be two side attachment points)

**Figure L.2 – Example of work positioning system for use on structures such as poles and masts (work positioning method 2)**

#### L.2.4 Fall arrest systems

**L.2.4.1** Fall arrest systems are the least preferable of all the personal fall protection systems because if the user lets go of (i.e. loses intentional contact with) the structure, it is very likely there will be a fall and falls, and the potential for falls, should always be avoided if possible.

**L.2.4.2** Fall arrest systems should be selected and used so that any potential fall would be as short as possible, with as little impact load on the user as possible and such that there would be no

impact with the ground, e.g. by keeping anchors high; using a shorter lanyard length. In addition, any potential for impact of the user with the structure or natural feature in a fall should be avoided or at least be such that the consequences are minimized.

### **L.2.5 Protecting against falls and injury**

Users of personal fall protection systems can reduce potential fall distances, impact loads and injury by:

- a) keeping anchor points above them (as high as possible);
- b) maintaining as little slack as possible in the anchor line or connecting lanyard;
- c) avoiding situations where there could be a pendulum (swing) fall;
- d) paying attention to clearance distances required, i.e. sufficient free space beneath the user, to avoid impact with the ground, structure or natural feature likely to cause injury, should a fall occur;
- e) avoiding the possibility of equipment such as anchor lines, slings or lanyards coming into contact with edges, abrasive surfaces or hot surfaces while under load.

### **L.2.6 Information on equipment used in personal fall protection systems**

#### **L.2.6.1 General**

For more general information on the selection of equipment, see **Part 2, 2.7**.

#### **L.2.6.2 Anchor devices**

Anchor devices used in personal fall protection systems should be unquestionably reliable. For work positioning and fall arrest systems, it is recommended that they have a minimum static strength of 15 kN when installed or placed in or on the structure or natural feature. Some jurisdictions may require static strengths higher than this. A static strength lower than 15 kN for anchor devices for work restraint systems may be acceptable, bearing in mind that this type of system is intended only to stop the user reaching zones where the risk of a fall exists and thus there should never be a fall. However, foreseeable misuse or unforeseeable circumstances should be taken into account and this may mean it is prudent to have the same static strength as for work positioning systems and fall arrest systems. More information on anchor devices is given in **Part 1, 1.3; Part 2, 2.7 and 2.11**, and **Part 3, Annex F**. While the advice under these references concerns rope access, the principles apply equally to other work positioning systems and to fall arrest systems.

#### **L.2.6.3 Harnesses**

**L.2.6.3.1** For work restraint, a simple belt might be considered to be all that is necessary to keep the user away from zones where the risk of a fall exists. However, some thought should be given to foreseeable misuse or to something unforeseen happening. Depending on the worksite, it might be prudent to use a work positioning belt, a work positioning harness or even a fall arrest harness.

**L.2.6.3.2** Work positioning systems usually employ a full body harness with attachment points for work positioning (e.g. single ventral and/or twin side attachment points) and for fall arrest (sternal and/or dorsal: see **L.2.6.3.3**) for attachment to a safety back-up system.

**L.2.6.3.3** A fall arrest system should incorporate a full body harness. Attachment points on full body harnesses for fall arrest, which are commonly marked with a capital letter 'A', should be either at a sternal (high front) position or at a dorsal (high back) position and should be located centrally at these positions. Both sternal and dorsal attachment types have their limitations, with advantages and disadvantages for each type. Users should be aware of these limitations when choosing which attachment point to use.

*NOTE For more information on the advantages and disadvantages of sternal and dorsal attachment points on full body harnesses, see British Standard BS 8437: 2005+A1: 2012, Annex E and UK Health and*

Safety Executive [Contract Research Report HSE 451/2002: Harness suspension: review and evaluation of existing information, 2.4.2.3.](#)

**L.2.6.3.4** Fall arrest attachment points should not be used if they are positioned in such a way that when the user is suspended from the harness, the loading is not central, e.g. if a fall arrest attachment point is located on a shoulder strap or to the side of the harness (which they should not be).

**L.2.6.3.5** Some full body harnesses are supplied with breakaway 'parking points' to keep the lanyard from obstructing the user while he/she is working. These are not fall arrest attachment points. Designs vary and the information supplied by the manufacturer should be followed.

**L.2.6.3.6** It is essential that a harness (or belt) fits the user properly and that there is enough adjustment to allow for clothing to be added or taken off. Harnesses should be correctly adjusted to provide a snug fit before use, checked regularly during use, and readjusted if necessary.

**L.2.6.3.7** It is also essential that a harness has an acceptable comfort level, not only while the user is carrying out normal work activities but also when the user is suspended in it, e.g. after a fall. Harness comfort can have a significant effect on the well-being of a user during the suspension phase of a fall. See **Part 3, Annex D** for a harness comfort and adjustability test.

#### **L.2.6.4 Energy absorbers**

**L.2.6.4.1** It is a generally accepted principle that the impact load experienced by the user in a fall should not exceed 6 kN. This can be achieved in a number of ways. In a fall arrest system, it is typically by the use of a specific energy absorber.

**L.2.6.4.2** Some commonly-used energy absorbers are made from textile webbing, using either a specially designed tear-webbing or layers of webbing stitched together, both of which are designed to tear under load, absorbing energy while doing so. These types of energy-absorbing lanyard are typically used to connect between the harness attachment point and a guided type fall arrester, which is attached to the anchor line. This so-called *connecting element* should be kept as short as feasible.

**L.2.6.4.3** Other energy absorbers include those built into the function of certain fall arrest devices, e.g. some designs of retractable type fall arrester, or those that are incorporated into an anchor line, e.g. as found in some designs of horizontal anchor line.

**L.2.6.4.4** Energy absorbers are usually intended to be activated only once, after which they should be dealt with in accordance with the information supplied by the manufacturer, e.g. discarded or, depending on the type, returned to the manufacturer or his authorized representative for re-setting.

#### **L.2.6.5 Guided type fall arresters**

**L.2.6.5.1** Guided type fall arresters are used on rigid and flexible anchor lines in a generally vertical plane. It is intended that when loaded in a downwards direction, they lock on to the anchor line, thereby arresting the fall. There are two types of (vertical) rigid anchor line: a rigid rail and a tensioned steel-wire cable. Rigid anchor lines usually incorporate or accompany a ladder system for ascent and descent. Flexible anchor lines are typically either textile rope or steel-wire cable.

**L.2.6.5.2** Most guided type fall arresters are intended to be used with specified anchor lines. Indeed, it is the requirement or intention of some standards that the anchor line be included with the guided type fall arrester at the point of sale. The performance of most guided type fall arresters relies heavily on the characteristics of the anchor line, so it is most important that the information supplied by the manufacturer of the guided type fall arrester is followed in this respect.

**L.2.6.5.3** Many guided type fall arresters are intended to travel both up and down the anchor line without user intervention, for safety and climbing efficiency reasons, so there is often no facility to enable the guided type fall arrester to be locked to the anchor line. The natural result is for the user to be in a fall factor two position (in relation to the position of connecting lanyard on the anchor line) during both upwards and downwards travel, which is generally not recommended, because the higher the fall factor, the greater distance any fall will be. This can be mitigated by the use of a very short

connecting lanyard (known as a *connecting element*), which would minimize the fall distance and impact load, should a fall occur. See **Annex Q** for information on fall factors.

**L.2.6.5.4** It is essential that connecting elements permanently fixed to guided type fall arresters are not extended, e.g. by adding an extra lanyard or additional connectors to it, unless the manufacturer specifically allows it. Doing so can affect the correct functioning of the device when called upon to arrest a fall.

**L.2.6.5.5** The proper functioning of many guided type fall arresters relies not only on the correct anchor line being used (see **L.2.6.5.2**) and the correct length of connecting element but also on other factors. There is evidence that not all guided type fall arresters will arrest a fall in every potential fall situation. This includes guided type fall arresters that meet recognized standards. An example is where the design of the guided type fall arrester is such that the cam has to be pulled downwards for it to engage with the anchor line, rather than doing so automatically. In this case, if the person is not beneath the guided type fall arrester as he/she falls, the cam is unlikely to engage with the anchor line and the fall is unlikely to be arrested.

**L.2.6.5.6** The situation described in **L.2.6.5.5** can arise when the connecting element is longer than that used during type testing and certification of the guided type fall arrester or if the fall is not a free fall, e.g. when a body snags on the structure during the fall or during a sliding fall.

**L.2.6.5.7** Users should be aware of the potential danger of some guided type fall arresters where the cam is open, i.e. not locked on to the anchor line, when the cam arm is in the horizontal position. A backwards or sometimes sideways fall on a tensioned anchor line or rigid rail can cause a horizontal load to be applied to the cam, keeping it open long enough not to arrest the fall. There have been numerous fatalities caused in this way. These occurred mainly when using rigid rail systems.

**L.2.6.5.8** Guided type fall arresters can be used as back-up devices on the safety line during rope access activities. If guided type fall arresters are to be used as back-up devices, it is recommended that they have cams that engage automatically with the anchor line during a fall.

#### **L.2.6.6 Retractable type fall arresters**

**L.2.6.6.1** Retractable type fall arresters are normally used in fall arrest systems without another back-up safety system. The retractable lanyard (a type of anchor line) retracts automatically back into its case when not under tension by the user, with the advantage that, in theory at least, any fall would be very short, i.e. just the distance taken for the brake to engage. Retractable type fall arresters can be used in rope access systems to provide back-up in place of or in addition to the safety line. When determining whether or not to use a retractable type fall arrester as part of a rope access system, the advice given in **L.2.6.6.2** to **L.2.6.6.6** should be considered.

**L.2.6.6.2** Unless the manufacturer specifically says otherwise, retractable type fall arresters should only be used in the totally vertical plane and the retractable lanyard should not be allowed to pass over an edge. This is for two reasons: to protect against abrasion or cutting of the retractable lanyard, particularly when under tension, and because many retractable type fall arresters do not work properly if any friction impedes the free running of the retractable lanyard (see **L.2.6.6.4**).

**L.2.6.6.3** Retractable type fall arresters which are allowed by the manufacturer to be used away from the vertical plane and are used in this way require a special awareness by the user of particular potential hazards, e.g. a pendulum fall of a type that could cause injury.

**L.2.6.6.4** Most retractable type fall arresters require their retractable lanyards to extract from their case at a certain speed before the locking mechanism starts to work. The required speed might not be achieved in anything less than a free fall, e.g. if the retractable lanyard runs over an edge during a fall or during an uncontrolled descent of the working line, i.e. where the user is not in full control of a descending device.

**L.2.6.6.5** A retractable type fall arrester should not be used in combination with a horizontal anchor line unless the manufacturer of the retractable type fall arrester specifically advises that it may be. Even so, it is recommended that tests are carried out to prove that they work together correctly. This

applies particularly but not exclusively to flexible horizontal anchor lines. The elongation characteristics of a horizontal anchor line can affect the correct functioning of some retractable type fall arresters, causing a series of lock-on/release/lock-on/release actions during loading, e.g. in a fall.

**L.2.6.6.6** Retractable type fall arresters should not be used in tandem (i.e. in pairs and at the same time) unless this is specifically allowed by the manufacturer. This is because a lock-on/release action similar to that described in **L.2.6.6.5** can occur.

**L.2.6.6.7** Users should read and understand thoroughly the information supplied by the manufacturer before using retractable type fall arresters in rope access operations, to ascertain whether or not they are suitable for the application in mind.

## **L.2.6.7 Horizontal anchor lines**

### **L.2.6.7.1 General**

**L.2.6.7.1.1** Horizontal anchor lines, also known as horizontal lifelines, may be rigid, e.g. a rigid rail, or flexible, e.g. a tensioned textile or steel-wire rope. As the name suggests, they are rigged in a horizontal plane, usually within a tolerance of  $\pm 15^\circ$ . Horizontal anchor lines can be used as part of a work restraint, rope access, work positioning, rescue or fall arrest system.

**L.2.6.7.1.2** For work restraint systems, horizontal anchor lines are used to stop a person from reaching zones where the risk of a fall exists, e.g. by the user being connected to the horizontal anchor line by a lanyard of a length that prevents them from reaching the unprotected edge of a building. When calculating the length of the lanyard, allowance should be made for any elongation (sag) in the horizontal anchor line if it were to come under load.

**L.2.6.7.1.3** For rope access systems, horizontal anchor lines can be used to provide variable anchor points (i.e. positions on the horizontal anchor line) for the working line and the safety line.

**L.2.6.7.1.4** For work positioning systems, horizontal anchor lines can provide variable anchor points for the lanyards (fixed length or adjustable) used to connect the user to the structure or natural feature.

**L.2.6.7.1.5** For fall arrest systems, horizontal anchor lines can be useful in providing variable anchor points for the lanyards (usually, energy absorbing lanyards) used to connect the user to the structure or natural feature.

**L.2.6.7.1.6** Both rigid and flexible horizontal anchor lines should only be installed and used by competent persons, see **L.3.4.6**.

### **L.2.6.7.2 Rigid horizontal anchor lines**

There are several types of rigid horizontal anchor line. Some use travellers (mobile anchor points), which travel along the rigid horizontal anchor line and to which the user attaches him/herself. Other types include a simple round-section rail (anchor rail) to which anchor slings may be attached or, for rope access, the working line and safety line. Rigid horizontal anchor lines, including anchor rails, are covered in more detail in **Annex F, F.2.2**.

### **L.2.6.7.3 Flexible horizontal anchor lines**

**L.2.6.7.3.1** Flexible horizontal anchor lines typically comprise textile or wire ropes tensioned in a generally horizontal plane between two anchor points. The anchor devices that provide these anchor points are known as extremity or end anchors. It is common, and often necessary to prevent sag, to have intermediate anchors positioned strategically between these extremity anchors.

**L.2.6.7.3.2** Flexible horizontal anchor lines may be permanently or temporarily installed. Permanent systems should be designed, installed and tested under the control of their respective manufacturers. Temporary flexible horizontal anchor lines are usually installed by users, who should have the necessary practical and theoretical skills, i.e. competence, to install a safe system and to use it safely.

**L.2.6.7.3.3** Great care has to be taken not to over-tension the flexible horizontal anchor line during installation, as over-tensioning can result in unforeseen and possibly unacceptable high loads at the extremity anchors. In addition, particular attention needs to be paid to the potential loads that could be applied to the extremity anchors should they be called upon to arrest a fall, which can be much higher than might be expected. The applied loads in an incorrectly tensioned system can be catastrophic. The loads should be calculated by a competent person and steps taken to ensure that the system is safe, before it is used. See **Part 2, Figure 2.4** for examples of multiplier effects caused by increase in angles.

**L.2.6.7.3.4** Clearance distances, which can be described as the distance in which the user would not hit the ground, structure or natural feature during a fall in a way likely to cause injury, need to be calculated accurately. They should allow for any deployment of an energy absorber and elongation (sag) of the flexible horizontal anchor line when under load, e.g. during the arrest of a fall, and should include at least an additional metre to act as a safety zone.

**L.2.6.7.3.5** As well as providing protection in personal fall arrest systems, flexible horizontal anchor lines can be used to provide protection against reaching zones where the risk of a fall exists (i.e. work restraint) or to support the user while moving along a generally horizontal plane (i.e. work positioning). When flexible horizontal anchor lines are used for support, e.g. the rope access technician needs to be in tension or suspension, two of them should be used in parallel, i.e. two flexible horizontal anchor lines side by side. Protected movement along the flexible horizontal anchor lines is achieved, for example, by connecting short anchor lanyards with appropriate connectors between the user's harness and the flexible horizontal anchor line(s). These are moved along the flexible horizontal anchor lines to aid access, either unsupported or supported, to various parts of the side of a structure or natural feature.

### **L.3 Climbing techniques used for access**

#### **L.3.1 General**

Three climbing methods are covered generally but not in detail: lead climbing, aid climbing and traversing.

#### **L.3.2 Lead climbing**

**L.3.2.1** By using the structure or natural feature for primary support, this access method allows a rope access technician, equipped with an appropriate harness and safety line or safety lines, to climb a structure or natural feature in any direction, without using their personal equipment for support. A second rope access technician (the *safety line controller*) manages the safety line(s) using an appropriate braking device, which protects the first (climbing) rope access technician in the event of a fall. The braking device is normally anchored directly to the structure or natural feature so that, in the event of a fall, the safety line controller would be able to disconnect from the system to summon help. The safety line or safety lines is/are passed appropriately through connectors attached to re-anchors at a frequency which minimizes the extent and severity of a fall. This is an advanced technique, which relies on having the correct equipment and using it correctly. This method of access should be well planned before being undertaken.

**L.3.2.2** Selection criteria for lead climbing equipment include appropriate:

- a) safety line(s), which should normally be dynamic 'single' mountaineering rope(s) and which should be of sufficient length to allow lowering of the rope access technician, either as part of the access/egress method or in an emergency;
- b) harnesses, which should contain attachment points suitable for fall arrest;
- c) braking devices, e.g. compatible with the safety line(s);
- d) anchor slings or other devices to provide re-anchors;
- e) connectors, which should have lockable gates.

**L.3.2.3** The route should be planned so that:

- a) there are no obstructions in the path of a potential fall, i.e. there are correct clearance distances;
- b) edges or abrasive or hot surfaces that may cause damage to equipment are avoided;
- c) there is appropriate placement of the first and subsequent re-anchors to minimize the potential fall distance;
- d) there is always minimal slack in the safety line(s);
- e) the safety line braking device is correctly operated by the safety line controller;
- f) it is possible to communicate adequately throughout the climb;
- g) that a workmate retrieval could take place;
- h) the possibility and potential consequences of user fatigue are taken into consideration.

**L.3.2.4** The equipment and techniques used in lead climbing may be used in planes other than vertical, e.g. in diagonal, horizontal or downward sloping situations, and also in aid climbing, where the safety line is controlled by the safety line controller to protect the first rope access technician in the event of a fall.

### **L.3.3 Aid climbing**

**L.3.3.1** In this access technique, the rope access technician is attached to the structure or natural feature via the harness using anchor lanyards and/or fall arrest lanyards, often in combination with anchor slings. It allows a rope access technician to move in any direction on a structure or natural feature, either in tension, suspension or by using the structure or natural feature for support.

**L.3.3.2** When aid climbing, the rope access technician should always have a minimum of two independent points of attachment to the structure or natural feature. When working in suspension, a third attachment is required to allow progression while maintaining the two independent points of attachment.

**L.3.3.3** Consideration should be given to the following:

- a) planning the route to ensure a potential workmate retrieval could take place;
- b) the selection and use of appropriate equipment, e.g. lanyard types and lengths with regard to minimizing the potential fall distances and fall factors, particularly in vertical aid climbing situations;
- c) the avoidance of edges or abrasive surfaces that may cause damage to equipment;
- d) the possibility and potential consequences of user fatigue;
- e) the use of safety lines and the lead climbing method (see L.6.2) in combination with the aid climbing technique;
- f) specific rescue methods that may be required when using this technique, e.g. where the distance between the rope access technician and the structure would make rescue lifting methods difficult.

### **L.3.4 Traversing**

**L.3.4.1** Traversing means moving in a generally horizontal direction (including diagonal) and usually consists of lead climbing, aid climbing or a combination of both. Consequently, traversing is generally covered in **L.3.2** and **L.3.3**. Additional guidance is given in **L.3.4.2** to **L.3.4.6** and **L.2.6.7**.

**L.3.4.2** Traverses should be set up and/or carried out such that they would prevent anything more than a very short fall and a low impact load.

**L.3.4.3** When traversing, the rope access technician should always have a minimum of two independent points of attachment to the structure or natural feature.

**L.3.4.4** Sometimes, traversing is carried out on anchor lines that are tensioned between anchors, e.g. in 'horizontal' anchor line systems, which are rigged in a generally horizontal plane. In tensioned systems such as these, the rope access technician is usually connected from their harness to the anchor line by a short anchor lanyard (using appropriate connectors), which protects him/her and allows progress along the anchor line. When the rope access technician needs to be in tension or suspension, the method is used in combination with a second tensioned safety line to which the rope access technician is attached by a second anchor lanyard.

**L.3.4.5** Consideration of rescue and retrieval usually means that anchor lines are rigged through a releasable system. For horizontal tensioned lines, a person or load may have secondary 'tag' or 'back' lines attached at either end.

**L.3.4.6** When anchor lines are tensioned, the increase in the loads at the anchor, anchor line terminations and other components in the system should be taken into account. The applied loads in an incorrectly tensioned system can be catastrophic. The loads should be calculated by a competent person and steps taken to ensure that the system is safe before it is used.





**IRATA International code of practice  
for industrial rope access**

**Part 3: Informative annexes**

**Annex M: Use of tools and other work  
equipment**

**September 2013**

The first edition of Annex M was published in January 2010.  
This edition was published in March 2013.

Amendments issued since publication in March 2013

Amd. No	Date	Text affected
1	2013-Sep-01	Front cover: <i>September 2013</i> replaces <i>2013 edition</i> . This page: change of IRATA address and telephone number. Date in footer updated. All the changes are classed as editorial.

Published by:

IRATA International  
First Floor, Unit 3  
Eurogate Business Park  
Ashford  
Kent  
TN24 8XW  
England

Tel: +44 (0)1233 754600

Email: [info@irata.org](mailto:info@irata.org)

Website: [www.irata.org](http://www.irata.org)

Copyright © IRATA International 2013

ISBN: 978-0-9544993-5-8

## **Annex M (informative)**

### **Use of tools and other work equipment**

#### **Introduction**

Annex M gives advice and other information that could be relevant to users of rope access methods and is one of a number of informative annexes in Part 3 of this code of practice. This informative annex should be read in conjunction with other parts of this code of practice, should not be used in isolation and is not intended to be exhaustive. For further advice, readers should refer to relevant specialist publications.

#### **M.1 General**

**M.1.1** It is essential that rope access technicians are competent in the use of their tools, especially power tools, and other work equipment when using them from anchor lines. Appropriate training should be given on their correct use in such a situation. The advice given may be different from that given for similar work on the ground and may involve additional precautions to be taken.

**M.1.2** It is important that all tools and equipment are suitable for the work intended and compatible with rope access techniques. In particular, they should not present a danger to the safe operation or integrity of the suspension system.

**M.1.3** Where tools and equipment are carried by the rope access technician, appropriate steps should be taken to prevent them being dropped or falling on to people below.

**M.1.4** All electrical equipment, plugs, sockets, couplers, leads etc. should be suitable for the environment in which they are to be used.

**M.1.5** Control measures should be implemented to minimize the potential for injury in the event of the rope access technician losing control of tools or equipment. Examples of control measures include self-actuating cut-off devices (so-called dead-man's handles) or rigging tools in such a way that, if control is lost, they swing away from the user.

**M.1.6** Where a rope access technician has to work with restricted vision and/or hearing (e.g. when using a welding mask), it is recommended that consideration be given to providing a second rope access technician to act as a watchman to protect against potential problems, e.g. fire or damage to equipment. The watchman should be positioned close by the rope access technician who is working with restricted vision and/or hearing.

#### **M.2 Small tools and equipment**

**M.2.1** Work using rope access techniques is generally more exposed than most other work methods. It usually requires the rope access technician to be in close proximity to the work itself and to any power source being used. As a result, certain tools, which can be used quite safely with conventional access systems, could cause risks to the rope access technician or to their suspension equipment, unless great care is taken. The site-specific additional risks posed by using tools and equipment in conjunction with rope access should be identified as part of the risk assessment and briefed to all rope access technicians and supporting staff before work begins.

**M.2.2** In many cases, the greatest danger is of dropping the tools on to people below. Therefore, to guard against this, small tools such as hammers, trowels and drills should be securely attached to the rope access technician's harness, e.g. by appropriate cords or lanyards, or to an independently suspended line. Alternatively, small items could be carried in a suitable container, e.g. a bucket or bag, securely attached to the rope access technician's harness. Where tools are carried like this, it is assumed that they will not be of such a weight that they might cause a significant reduction in the factor of safety of the suspension system, either as a whole or any part of it.

**M.2.3** Where a tool needs to be pressed hard against the work face, measures may be necessary to stabilize the rope access technician to counter the reactive force, e.g. by using an anchor lanyard of appropriate length attached to the structure.

**M.2.4** It is essential that moving parts of tools are kept clear of the operator, power leads and the suspension equipment.

### **M.3 Power leads**

**M.3.1** Power leads (e.g. electrical cables or pneumatic hoses) could become entangled with the suspension system or be cut or fractured through abrasion or by any tools being used. Therefore, they should be kept clear of the rope access technician and of the tool's moving parts.

**M.3.2** The connections between the various lengths of a lead should be constructed or assembled to be self-supporting for the length of their drops. In some cases, they might need to be adequately supported or secured to enable them to carry their own weight. For instance, they could be secured to and supported by a suitable suspension rope. Particular care should be taken to avoid placing tensile or dynamic loads on plugs, terminals etc.

**M.3.3** Cordless power tools avoid the difficulties associated with leads (see **M.3.1**) and are recommended where they are suitable for the work to be carried out.

### **M.4 Bulky, awkward or heavy equipment**

**M.4.1** Bulky, awkward or heavy equipment (e.g. over 8 kg), that might interfere with safe working or affect the safety of the suspension equipment or any part of it, e.g. by the increase in mass, should be fitted with a separate suspension system secured to an independent anchor. Anchors and suspension ropes used for equipment should be clearly identified to avoid confusion with those used to support persons.

**M.4.2** Equipment should be suspended correctly balanced so that it can be positioned and moved easily to its various work locations. It should be properly supported against the work face and be stable while in use. Several suspension lines may have to be fitted to the tool to enable it to be moved easily about the work face. This can normally be achieved by fixing light anchors around the work face.

**M.4.3** Workers using bulky, awkward or heavy equipment should be able to position themselves and their suspension equipment well away from any moving parts. If this is not possible, then extra guards or shields should be fitted. Effective communication between those working the tools and those manipulating the suspension ropes is essential. Two-way radios may be necessary to achieve this.

**M.4.4** When working in conjunction with an alternative or ancillary lifting system, rope access technicians and their equipment should be protected, e.g. against the risk of entanglement or crushing.

### **M.5 Hot work**

**M.5.1** Care should be taken by the rope access technician to protect against potential personal injury while carrying out hot work, e.g. by sealing the gap between overalls and boots or sleeves and gloves to prevent hot material such as weld or grit entering.

**M.5.2** For certain types of hot work, rope access equipment such as anchor lines and harnesses may need special protection, e.g. anchor lines could be protected in the immediate hot-work area by attaching heat resistant anchor line protectors around them.

## **M.6 Blasting, spraying and jetting from anchor lines**

**M.6.1** Before work commences, training is necessary to cover the precautions and techniques required to deal with the additional hazards of using high-pressure tools when associated with rope access, over and above standard safety measures for using this equipment on the ground.

**M.6.2** Where equipment is operated by air or water, consideration should be given to supporting or guarding the hoses and ancillary equipment, where appropriate, to ensure that they will not be damaged or come uncoupled through carrying their own weight and thus become a hazard for the rope access technician and his/her equipment. Hose connections to the tools should be checked before use and provision should be made so that the air/water supply can be turned off in an emergency. Only certified hoses and fittings should be used. Hose whip checks or hose coupling safety locks or both should be fitted to the hoses. Hoses should be firmly secured close to the operator. Hoses should be fully uncoiled when in use.

**M.6.3** Before carrying out ultra-high-pressure water jetting, blasting or spraying, steps should be taken to minimize the likelihood of injury or damage to rope access equipment, e.g. if the lance or blast nozzle is inadvertently pointed at any part of the user's body (or that of another person) or at vulnerable rope access equipment. Protection could be achieved by various means, e.g. using a lower pressure and/or, for the prevention of injury, by providing suitable protection to the legs and feet such as leg guards, protective over-boots or metatarsal guards. The length of the lance could be extended to make it difficult for the user to point the blast nozzle at his/her body. Appropriate attachments with resistance to cutting, melting and abrasion should be used when any grinding /welding/ blasting /ultra-high-pressure water jetting works are undertaken.

**M.6.4** Where the reaction from the high-pressure tools could unbalance the rope access technician and cause an accident, subsidiary anchor lines should be used to tension the rope access technician in position.

**M.6.5** Exclusion zones (buffer zones) should be established to keep unauthorised personnel away from the blast area and to protect against other hazards, e.g. falling or flying debris and noise, and the possibility of the lance being dropped onto them.

**M.6.6** It is essential that a good communications system is established. Pre-arranged hand signals are often used because a microphone is unsuitable when blasting, due to the noise. A common and effective technique to attract the blaster's attention is for the Level 3 to cut off the air supply.



**IRATA International code of practice  
for industrial rope access**

**Part 3: Informative annexes**

**Annex N: Recommended list of information to be  
kept on site**

**September 2013**

The first edition of Annex N was published in January 2010.  
This edition was published in March 2013.

Amendments issued since publication in March 2013

Amd. No	Date	Text affected
1	2013-Sep-01	Front cover: <i>September 2013</i> replaces <i>2013 edition</i> . This page: change of IRATA address and telephone number. Date in footer updated. All the changes are classed as editorial.

Published by:

IRATA International  
First Floor, Unit 3  
Eurogate Business Park  
Ashford  
Kent  
TN24 8XW  
England

Tel: +44 (0)1233 754600

[www.irata.org](http://www.irata.org)

Copyright © IRATA International 2013

ISBN: 978-0-9544993-5-8

## **Annex N (informative)**

### **Recommended list of information to be kept on site**

#### **Introduction**

Annex N gives advice and other information that could be relevant to users of rope access methods and is one of a number of informative annexes in Part 3 of this code of practice. This informative annex should be read in conjunction with other parts of this code of practice, should not be used in isolation and is not intended to be exhaustive. For further advice, readers should refer to relevant specialist publications.

#### **N.1 List of information**

The following list gives details of information recommended to be kept on site. While some of this information would need to be hard copy (i.e. paper), other information could be in an electronic format:

- a) a copy of the employer's employment liability insurance;
- b) a copy of a letter from the insurance company acknowledging that they will give third party cover for the method of work (i.e. rope access);
- c) an equipment log, (e.g. a manifest or other suitable record) which lists all the equipment on site with sufficient identification to enable cross reference to inspection records or certificates of conformity, together with recommended safe working load, working load limit or maximum or minimum rated load, as and where appropriate. (On projects of short duration, under about eight weeks, these logs may be kept at the head office.);
- d) the location of and access to the information supplied by the manufacturer for the equipment on site, as listed in the equipment log;
- e) information about the use and care of any chemicals that may be used on site;
- f) a safety method statement including typical work details and standard practices;
- g) personal log books, to be carried by all persons who are working using rope access techniques;
- h) under certain jurisdictions, a construction phase health and safety plan;
- i) under certain jurisdictions, notification of the work, to be displayed on site.





**IRATA International code of practice  
for industrial rope access**

**Part 3: Informative annexes**

**Annex O: The effect of wind and height on  
working times**

**September 2013**

The first edition of Annex O was published in January 2010.  
This edition was published in March 2013.

Amendments issued since publication in March 2013

Amd. No	Date	Text affected
1	2013-Sep-01	Front cover: <i>September 2013</i> replaces <i>2013 edition</i> . This page: change of IRATA address and telephone number. Date in footer updated. All the changes are classed as editorial.

Published by:

IRATA International  
First Floor, Unit 3  
Eurogate Business Park  
Ashford  
Kent  
TN24 8XW  
England

Tel: +44 (0)1233 754600

[www.irata.org](http://www.irata.org)

Copyright © IRATA International 2013

ISBN: 978-0-9544993-5-8

## Annex O (informative)

### The effect of wind and height on working times

#### Introduction

Annex O gives advice and other information that could be relevant to users of rope access methods and is one of a number of informative annexes in Part 3 of this code of practice. This informative annex should be read in conjunction with other parts of this code of practice, should not be used in isolation and is not intended to be exhaustive. For further advice, readers should refer to relevant specialist publications.

#### O.1 General

**O.1.1** Harsh climatic conditions such as those caused by high winds can affect the number of consecutive hours a rope access technician could be expected to work safely in any one shift. Employers should be aware that, in such conditions, periods of consecutive working might need to be reduced.

*NOTE* Other climatic conditions that could affect working times, which employers should also take into account, include high and low air temperatures. These are not covered in this annex but it is intended to do so in a future revision.

**O.1.2** Steps can sometimes be taken to combat the effects of the wind, e.g. by the use of sheeting as shown in **Table O.1** or other types of barrier, or by working on the lee side of a building rather than in an exposed area.

**O.1.3** **Table O.1** provides an example of how different wind speeds can affect working times when working at height. The information is based on work done by Toronto University. These times are likely to vary considerably, depending on factors such as the surrounding air temperature, the height above ground and the precise nature of the worksite.

**O.1.4** The values in **Table O.1** show what might be acceptable working times in an eight-hour shift at different wind speeds when the worksite is unprotected and what they might be when the worksite is protected, in this case by containment netting or containment sheeting.

**Table O.1 — Possible working times in an eight-hour shift at different wind speeds**

Wind speed	Working time limitations		
	Unprotected	Protected with containment netting	Protected with containment sheeting
Metres per second	Hours	Hours	Hours
2	8	8	8
5	5	7	8
7	4	6	7
9	3	5	6
11	2	4	5
14	1.5	3	4
28	0.5 a)	0.5 a)	0.5 a) b)

#### Key

- a) Acceptable for emergency work only.
- b) The containment sheeting could be in danger of blowing away.

## O.2 Other information

Other information on recommended maximum wind speeds when working includes:

- a) BS 5975:2008+A1, in relation to false-work, (see 17.5.1.9) refers to the maximum wind speed during which working operations can take place as being normally limited to that of a wind force of six on the Beaufort wind force scale. This corresponds to a wind speed of between 10.8 m/s and 13.8 m/s;
- b) The Construction Industry Research and Information Association (CIRIA) publication C703, *Crane Stability on Site*, 2003 edition (out of print), gives 20 m/s as a typical maximum in-service wind speed for a tower crane.
- c) The Prefabricated Aluminium Scaffolding Manufacturers Association (PASMA) *Operator's Code of Practice* recommends that work upon a tower should cease if the wind speed exceeds 17 mph. (7.6 m/s).



**IRATA International code of practice  
for industrial rope access**

**Part 3: Informative annexes**

**Annex P: Recommended actions for the protection  
of anchor lines**

**September 2013**

This first edition of Annex P was published in March 2013

Amendments issued since publication in March 2013

Amd. No	Date	Text affected
1	2013-Sep-01	Front cover: <i>September 2013</i> replaces <i>First edition</i> . This page: change of IRATA address and telephone number. Date in footer updated. Table P.1, 3b, third column: after <i>Go to 4</i> , the words <i>see next page</i> have been deleted. All the changes are classed as editorial.

Published by:

IRATA International  
First Floor, Unit 3  
Eurogate Business Park  
Ashford  
Kent  
TN24 8XW  
England

Tel: +44 (0)1233 754600

[www.irata.org](http://www.irata.org)

Copyright © IRATA International 2013

ISBN: 978-0-9544993-5-8

## Annex P (informative) Recommended actions for the protection of anchor lines

### Introduction

Annex P gives advice and other information that could be relevant to users of rope access methods and is one of a number of informative annexes in Part 3 of this code of practice. This informative annex should be read in conjunction with other parts of this code of practice, should not be used in isolation and is not intended to be exhaustive. For further advice, readers should refer to relevant specialist publications.

### P.1 General

**P.1.1** This informative annex provides a table (**Table P.1**), which takes a hierarchical approach in the recommended order of actions to obtain the best achievable method of protection for anchor lines at a worksite.

**P.1.2** Once it has been established that rope access is an appropriate access system and the hazards have been identified (see 1 in **Table P.1**), the lower the number chosen between 2 and 4 in the column titled *Decision* and the corresponding action taken (see the column titled *Action*), the more effective and reliable the protection system is likely to be. This process may be remembered (in English) by the acronym **RAP**:

Remove (the hazard, where feasible)

Avoid (the hazard)

Protect (against the hazard).

**P.1.3** Anchor line protection is covered in more detail in **Part 2, 2.7.10, 2.11.3.1 and 2.11.3.2**. Pre-use checks and inspection are covered in **Part 2, 2.10**.

### P.2 Examples of hazards





The following are examples of hazards that should be taken into account when protecting anchor lines. This list is non-exhaustive:

- a) sharp edges such as may be found on steel work, cable trays, gratings, glass façades, composite panels;
- b) abrasive edges and surfaces such as coping stones, rock protrusions, corroded structures;
- c) trapping and cutting areas such as manhole covers, hatches, doorways;
- d) heat sources and the risk of melting from such as hot pipes, exhaust gases, lighting;
- e) hot work such as welding or cutting;
- f) corrosive substances such as chemical deposits or spillages;
- g) tools such as angle grinders, chainsaws, ultra-high-pressure lances, grit blasters, power drills.

**Table P.1 — Hierarchy for the protection of anchor lines against hazardous surfaces**

Decision		Action <i>(Assumes it has been established that rope access is a suitable method of work)</i>
<p><b>1. Hazard identification</b></p> <p>Have all the hazards in the planned anchor line path been identified and is it possible to rig anchor lines away from any hazard or to protect them against those hazards?</p>	<p><b>Yes</b> ➡</p>	<p>Identify all hazards in the path of the anchor line for its entire length and taking into account the duration of the rope access task. Include any potential rescue scenario.</p> <p>Allow for any potential vertical and transverse movement of the working line and safety line either while under load, e.g. during working or rescue operations, or when not under load, e.g. due to the effects of vibration or wind.</p> <p>Consider the consequences of working line failure, e.g. deployment of the back-up device; stretch of the safety line; anchor lines moving over an edge in a set-up rigged for rescue.</p> <p><b>Go to 2</b></p>
	<p><b>No</b> ➡</p>	<p>Use another access method.</p> <p><b>Go to 6</b></p>
<p><b>2. Remove the hazard</b></p> <p>Can the edge/other hazards be eliminated?</p>	<p><b>Yes</b> ➡</p>	<p>Where feasible, remove the hazard, e.g. remove grating; remove sharp or abrasive surfaces; ensure any heat sources are isolated.</p> <p><b>Go to 5</b></p>
	<p><b>No</b> ➡</p>	<p><b>Go to 3a</b></p>
<p><b>3a. Avoid the hazard</b></p> <p>Can the anchor lines be rigged so they hang completely free and clear of the hazards (i.e. without the use of re-anchors or deviations)?</p>	<p><b>Yes</b> ➡</p>	<p>Rig anchor lines (e.g. using Y-hangs) so that they hang free and clear of the hazard(s) for their entire length and for the duration of the rope access task.</p> <p>Consider, as an additional safety measure, the appropriateness of protecting against the hazards that have already been avoided by the free hang, e.g. by placing a fire blanket over any hot pipes in the vicinity of the anchor lines.</p> <p><b>Go to 5</b></p>
	<p><b>No</b> ➡</p>	<p><b>Go to 3b</b></p>
<p><b>3b Avoid the hazard</b></p> <p>Can the hazard be avoided by a method other than a completely free hang?</p> <p><i>3b continues on next page.</i></p>	<p><b>Yes</b> ➡</p>	<p>Examples of this type of hazard avoidance (in order of preference) are: smooth-surfaced scaffolding tube clamped in position over which the anchor lines run; deviations of suitable strength connected independently to the working line and the safety line; anchor lines re-anchored.</p> <p>If re-anchors are used, ensure the anchor lines are not exposed to the hazard at any time, e.g. by placing edge or anchor line protection (<b>see 4</b>).</p> <p><b>Go to 5</b></p>



<p><b>3b continued</b></p>	<p><b>No</b>  </p>	<p><b>Go to 4</b></p>
<p><b>4. Protect against the hazard</b></p> <p>If the hazard, e.g. edges; abrasive surfaces; heat sources, cannot be avoided, can effective protection appropriate for the task be installed?</p>	<p><b>Yes</b>  </p>	<p>Carry out a thorough assessment of the hazards to define the level of robustness of protection required, e.g. whether edge protectors and/or anchor line protectors are appropriate and which type should be used.</p> <p>Install protection based on whether it is an edge to be protected against or an abrasive, smooth, or hot surface or heat source and whether the contact angle is small or large. Select types of protection which have been demonstrated to control the particular type of hazard. Ensure edge protectors, anchor line protectors and anchor lines stay in their intended position.</p> <p>Protectors that do not enclose the anchor line are easier to pass and to observe damage than wrap-around sheath types, particularly at a top edge.</p> <p>Where individual enclosed anchor line protectors are to be used, each anchor line should be independently protected.</p> <p><b>Go to 5</b></p>
	<p><b>No</b>  </p>	<p><b>Go to 6</b></p>
<p><b>5. Final verification</b></p> <p>Is the level of protection robust enough to reduce the chance of damage to the working line to an acceptable level and also ensure safety line integrity will remain uncompromised in the event of a working line failure?</p>	<p><b>Yes</b>  </p>	<p>Define the method chosen, including implementation within the rescue plan.</p> <p>Verify as outlined in the first column on the left (beneath the heading <i>Final verification</i>).</p> <p>Start work only after a pre-use check for system integrity and recheck regularly.</p>
	<p><b>No</b>  </p>	<p><b>Go to 6</b></p>
<p><b>6. DO NOT PROCEED</b></p>		



**IRATA International code of practice  
for industrial rope access**

**Part 3: Informative annexes**

**Annex Q: Fall factors, fall distances and associated  
risks**

**September 2013**

The first edition of Annex Q was published in January 2010.  
This edition was published in March 2013.

Amendments issued since publication in March 2013

Amd. No	Date	Text affected
1	2013-Sep-01	Front cover: <i>September 2013</i> replaces <i>2013 edition</i> . This page: change of IRATA address and telephone number. Date in footer updated. All the changes are classed as editorial.

Published by:

IRATA International  
First Floor, Unit 3  
Eurogate Business Park  
Ashford  
Kent  
TN24 8XW  
England

Tel: +44 (0)1233 754600

[www.irata.org](http://www.irata.org)

Copyright © IRATA International 2013

ISBN: 978-0-9544993-5-8

## Annex Q (informative)

### Fall factors, fall distances and associated risks

#### Introduction

Annex Q gives advice and other information that could be relevant to users of rope access methods and is one of a number of informative annexes in Part 3 of this code of practice. This informative annex should be read in conjunction with other parts of this code of practice, should not be used in isolation and is not intended to be exhaustive. For further advice, readers should refer to relevant specialist publications.

#### Q.1 General

**Q.1.1** Fall factors are used to measure the severity of a fall when using ropes or lanyards and are defined as the length of a potential fall divided by the length of rope or lanyard available to arrest it.

**Q.1.2** An understanding of fall factors and their effects is important in both the planning and application of rope- or lanyard-based access work. Those who understand the effects are better able to select the correct equipment for the application or look for alternative methods if the potential effects are unacceptable.

#### Q.2 Explanation of fall factors and their effects

**Q.2.1** **Figure Q.1** shows a person attached to a rigid horizontal anchor line (a rigid rail) in three different positions. The rigid horizontal anchor line depicted is for illustration purposes only and has been chosen for simplicity and clarity. The far-right position 3 shows a person in a fall factor two situation (FF 2). This is considered to be a high severity fall factor. The centre position 2 shows a fall factor one situation (FF 1), which is considered to be a medium severity fall factor, and the far-left position 1 shows a very low fall factor situation (almost FF 0), i.e. a very low severity fall factor. The fall factor scenario shown in **Figure Q.1** also applies when other anchor methods are employed, e.g. where the lanyard is connected to an anchor device fixed to masonry or to a vertical anchor line (when the connection would normally be via an anchor line device).

**Q.2.2** Where someone is connected to an anchor by a lanyard of, say, one metre length and the harness attachment point is level with that anchor, (e.g. as shown in 2 in **Figure Q.1**), the potential fall distance is one metre. (In this example and the one in **Q.2.3**, no account is taken of any elongation of the lanyard.) The length of the fall (one metre) divided by the length of lanyard available to arrest it (one metre) gives a result of one ( $1 \div 1 = 1$ ), i.e. fall factor one (FF 1).

**Q.2.3** Using the same length of lanyard as in **Q.2.2**, i.e. one metre, if the person climbs above the anchor to the maximum height that the lanyard allows (e.g. as shown in 3 in **Figure Q.1**), the length of the potential fall is now two metres, the length of the lanyard remains the same at one metre and the fall factor is two ( $2 \div 1 = 2$ ).

**Q.2.4** Although the lanyard length is the same in both the examples given in **Q.2.2** and **Q.2.3**, the distance of the two falls is markedly different and so too can be the effect. The impact loads experienced by the user and the anchor in the example given in **Q.2.3** (FF 2) are likely to be much higher than those in the example given in **Q.2.2** (FF 1) and the potential for collision of the user with the ground or structure is also increased.

**Q.2.5** If the position of the person is as shown in 1 in **Figure Q.1**, the result of a fall is likely to be much less serious than those shown in 2 and 3. The fall would be very short; the impact load on the user and the anchor is likely to be insignificant and, therefore, the chance of the user hitting the structure or ground is minimized, as is the force at which the user might collide with them.

### **Q.3 Other considerations**

**Q.3.1** The length of a potential fall and its consequences and/or the calculation of the fall factor are sometimes not quite as obvious as it seems. In some situations, the length of the potential fall and the impact loads likely to be experienced can be increased without realizing it. For example, a common practice is to pass an anchor sling, such as a wire strop or webbing sling, around the structure and link it with a connector, which is then used as the anchor point for the user, either directly or via a lanyard. If the user moves above that anchor point (which is not recommended), the anchor sling could be raised above its natural hanging (lowest) position, see **Figure Q.2**. This would affect the potential fall distance.

**Q.3.2** In the scenario described in **Q.3.1**, the length of the potential fall is no longer directly related to the length of the lanyard but is now related to a combination of the length of the lanyard plus the distance from the lowest point at which the anchor sling would hang naturally to its highest point in use. The combined effect of the increase in potential fall distance and poor energy-absorbing characteristics of the strop or sling is likely to produce unacceptable impact loads on the user in a fall, thereby increasing the risk of injury. The increased length of the potential fall also increases the risk of the user colliding with the ground or structure.

**Q.3.3** An increased fall distance can also arise in situations other than those described in **Q.3.1** and **Q.3.2**. An example is if an anchor lanyard or an anchor sling is attached to the structure in such a way that it is free to slide, such as when it is attached to a vertical or diagonal section of steel lattice-work (not recommended), see **Figure Q.3**. (In this example, in addition to the increased fall distance, there is also a danger of incorrect loading and failure of the connectors.) A fall distance can also be increased by elongation of the safety line when a load is applied to it, e.g. in a fall.

**Q.3.4** It is essential that fall factors are kept as low as possible at all times so that, should a fall occur, the resulting impact loads on the user are minimised. If the combined length of all the connecting elements (e.g. lanyard plus connectors plus anchor sling) is kept as short as possible and is combined with a low fall factor, e.g. by always working below the anchor point, the user is less likely to collide with the structure or the ground and the potential impact loads experienced are also likely to be low.

**Q.3.5** It should be remembered that the impact loads experienced in a fall depend not only on the fall factor and length of fall but also on the characteristics of the connecting elements and especially their ability to absorb energy, e.g. the amount of energy absorbed by an anchor line can be influenced by the length of the anchor line above the anchor line device. Energy absorption capability is important, especially in high fall factor situations, and while it should be to an acceptable level (which varies between countries), the increase in fall distance that it brings with it, e.g. by elongation of the connecting elements, can also be a hazard.

**Q.3.6** To minimize impact loads on the user in a fall, it may be necessary to consider the incorporation of commercially-made energy absorbers, especially where the energy-absorbing characteristics of the lanyard are poor and/or the potential fall distance is considered to be high. When energy absorbers are activated, they extend, or allow slippage, e.g. along the anchor line, and thus the effective length of the lanyard is increased, so the reduced impact load is at the expense of a longer fall, with an increased risk of collision and injury.

**Q.3.7** There are examples in personal fall protection where a good understanding of fall factors allows equipment with reduced energy-absorbing capabilities to be used safely, as long as fall factors are kept very low and as close to zero as possible. This can be advantageous in a number of different ways: for example, the use of low stretch ropes for anchor lines allows more precise work positioning and more efficient ascending than dynamic rope would, and the use of short non-stretch connecting elements during aid climbing helps the user to conserve energy and to work more efficiently. Thus, it is often preferable to use equipment with low energy absorption characteristics combined with a very low fall factor, rather than accept a high fall factor with increased energy absorption and the resulting increased potential fall distance and risk of injury through collision with the ground or structure.

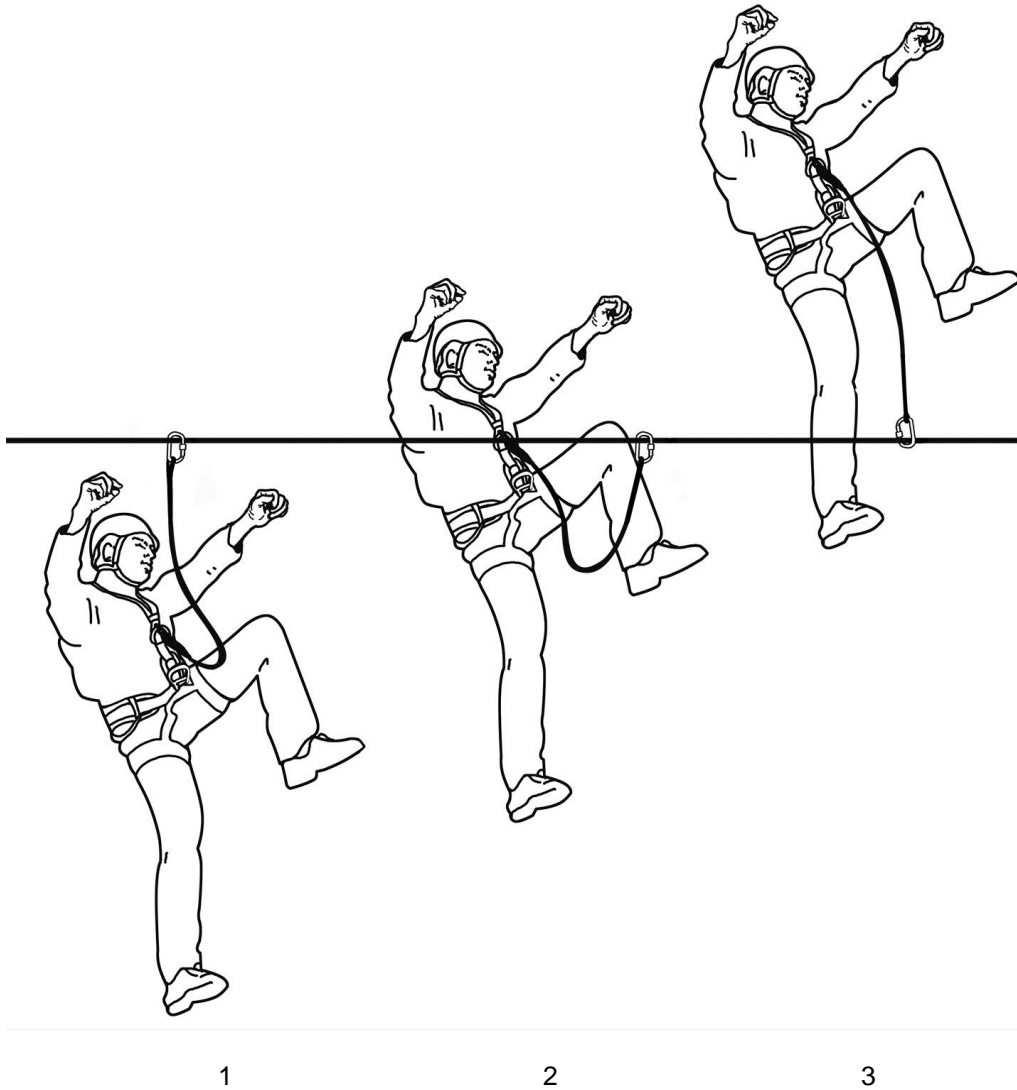

**Key**

- 1 Very low fall factor (almost 0)
- 2 Fall factor 1
- 3 Fall factor 2

**Figure Q.1 — Illustration to show different fall factors**



**Figure Q.2 — Lifting an anchor sling from its normal hanging position increases the potential fall distance**



**Figure Q.3 — Attaching an anchor lanyard (or anchor sling) in such a way that it can slide downwards during a fall increases the potential fall distance**



# **IRATA International code of practice for industrial rope access**

## **Part 4: Local legislation: UK**

**Please note that this version of Part 4 applies to the UK only.**

**December 2013**



The first edition of Part 4 was published in January 2010.  
This edition was published in March 2013.

Amendments issued since publication in March 2013

Amd. No	Date	Text affected
1	2013-Dec-01	Front cover: <i>December 2013</i> replaces <i>2013 edition</i> . This page: change of IRATA address and telephone number. Page 1: title of Part 4 adds <i>United Kingdom only</i> . Page 1: Introduction: new last sentence to paragraph 1 reference Northern Ireland. Page 1: 4.1, paragraph 1: instructions on how to make hyperlink deleted; CDM Regulations: note added; Construction (Head protection) Regulations deleted. Page 2: additional guidance on Electricity at Work Regulations included; Health and Safety (First Aid) Regulations: note added; Highways Act 1980: note added; paragraph on LOLER: typo corrected; Management of Health and Safety at Work Regulations: guidance reference deleted. Page 3: RIDDOR information updated; 4.2.1: new last sub-clause added (4.2.1.3). Page 4: 4.2.4 Construction (Head Protection Regulations) deleted and the rest of 4.2 renumbered. Note added to new 4.2.4 Personal Protective Equipment at Work Regulations. Page 7: 4.2.11 Reporting of Injuries, Diseases and Dangerous Incidents: information updated and new sub-clauses added (4.2.11.3, 4.2.11.4 and 4.2.11.5). Date in footer updated.

Published by:

IRATA International  
First Floor, Unit 3  
Eurogate Business Park  
Ashford  
Kent  
TN24 8XW  
England

Tel: +44 (0)1233 754600

[www.irata.org](http://www.irata.org)

Copyright © IRATA International 2013

ISBN: 978-0-9544993-6-5

## Part 4: Local legislation: United Kingdom only

### Introduction

Part 4 provides information on legislation that applies in a particular country or region, in this case the United Kingdom (UK). There are variations to the legislation quoted in Northern Ireland, see [www.hseni.gov.uk](http://www.hseni.gov.uk).

For legislation applicable to countries or regions other than the UK, readers should consult the IRATA International code of practice adopted by that particular area, e.g. Australia, Benelux, Brazil, North America, South Africa, South-east Asia, or the appropriate Regional Advisory Committee (RAC).

As well as providing information on UK legislation, this UK version of Part 4 also gives details of Health and Safety Executive (HSE) approved codes of practice, guidance and other supporting literature. It first lists the legislation alphabetically and then explains the requirements of some of it. Finally, information is provided on the relationship between legislation and standards.

It should be noted that Part 4 is not intended as an interpretation of the law and does not relieve employers of their duties under the various legal requirements that may relate to their specific location, situation and applications.

Although care has been taken to ensure, to the best of IRATA International's knowledge, that the content of Part 4 is accurate, IRATA International assumes no responsibility for any errors, omissions or misinterpretations of such content or any loss or damage arising from or related to its use.

### 4.1 Applicable UK legislation, HSE approved codes of practice and guidance

The following list details UK legislation applicable to rope access work. It refers to the formal legislative reference number, i.e. the Statutory Instrument (SI) and provides the titles and reference numbers of associated HSE approved codes of practice (known as ACoPs) and guidance documents. Many of these documents have always been free of charge and many others have become so since November 2009. Hyperlinks are provided, giving direct access to the documents via a computer.

Confined Spaces Regulations 1997 ([SI 1997/1713](#)) and HSE approved code of practice and guidance: *Safe work in confined spaces* ([HSE L101](#))

Construction (Design and Management) Regulations 2007 (known as the *CDM Regulations*) ([SI 2007/320](#)) and HSE approved code of practice *Managing health and safety in construction* ([HSE L144](#)). Also see **4.2.2**.

*NOTE* At the time of publication of this version of ICOP Part 4, these regulations are under review.

Control of Asbestos Regulations 2012 ([SI 2012/632](#)), and HSE approved code of practice and guidance *Work with materials containing asbestos* ([HSE L143](#))

Control of Noise at Work Regulations 2005 ([SI 2005/1643](#)) and HSE guidance ([HSE L108](#))

Control of Substances Hazardous to Health Regulations 2002 (known as *COSHH*) ([SI 2002/2677](#)) (as amended), plus: HSE approved code of practice and guidance *Control of substances hazardous to health (fifth edition)* ([HSE L5](#)); HSE guidance *Workplace exposure limits*, 2011 update ([EH40](#)); HSE guidance *Working with substances hazardous to health* ([HSE INDG 136 REV 5](#)); HSE guidance *A step by step guide to COSHH assessment* ([HSG 97](#)) and *Fumigation* ([HSG 251](#))

Control of Vibration at Work Regulations 2005 ([SI 2005/1093](#)) and HSE guidance *Hand-arm vibration* ([HSE L140](#))

Electricity at Work Regulations 1989 ([SI 1989/635](#)) plus HSE guidance *Electrical safety and you* ([INDG 231 Revision 1, 2012](#)); *Electricity at work - Safe working practices* ([HSG85 Third edition, 2013](#)); *Memorandum of guidance on the Electricity at Work Regulations 1989* ([HSR25 Second edition, 2007](#)) and *Maintaining portable and transportable electrical equipment* ([HSG107 Third edition, 2013](#))

#### [Health and Safety at Work etc. Act 1974](#)

Health and Safety (First Aid) Regulations 1981 (SI 1981/917), amended by the Health and Safety (Miscellaneous Amendments) Regulations 2002 (SI 2002/2174), and HSE approved code of practice and guidance *First aid at work* (HSE L74)

*NOTE* The regulations were amended on 01 October 2013 to remove the requirement for HSE to approve first aid training and qualifications. Information, including the regulations and guidance for employers is available at [www.hse.gov.uk/firstaid/](http://www.hse.gov.uk/firstaid/)

Health and Safety (Safety Signs and Signals) Regulations 1996 ([SI 1996/341](#)) and HSE guidance *Safety signs and signals* ([HSE L64](#))

#### [Highways Act 1980](#)

*NOTE* At the time of publication of this version of ICOP Part 4, there are outstanding changes not yet made by the [legislation.gov.uk](http://legislation.gov.uk) editorial team to Highways Act 1980. Any changes that have already been made appear in the content and are referenced with annotations.

Lifting Operations and Lifting Equipment Regulations 1998 (known as *LOLER*) ([SI 1998/2307](#)), amended by the Health and Safety (Miscellaneous Amendments) Regulations 2002 ([SI 2002/2174](#)), plus HSE approved code of practice and guidance *Safe use of lifting equipment 1998* ([HSE L113](#)), [HSE Open learning guidance](#) and HSE guidance document [ACOLAR LOLER](#), which explains the relationship between LOLER and rope access. Also see **4.2.5**.

Management of Health and Safety at Work Regulations 1999 (known as the *MHSW Regulations*) ([SI 1999/3242](#)). Also see **4.2.6**.

Manual Handling Operations Regulations 1992 ([SI 1992/2793](#)), amended by the Health and Safety (Miscellaneous Amendments) Regulations 2002 ([SI 2002/2174](#)), plus HSE guidance *Manual handling, Manual Handling Operations Regulations 1992 (as amended)* (HSE [L23](#)) and *Getting to grips with manual handling* ([INDG 143](#)). Also see **4.2.8**.

#### [Mineral Workings \(Offshore Installations\) Act 1971](#)

Offshore Installations and Pipeline Works (Management and Administration) Regulations 1995 (known as *MAR*) ([SI 1995/738](#)) and HSE guidance ([HSE L70](#))

Offshore Installations and Wells (Design and Construction) Regulations 1996 (known as *DCR*) ([SI 1996/913](#)) and HSE guidance (HSE [L84](#) and [L85](#))

Offshore Installations (Prevention of Fire and Explosion and Emergency Response) Regulations 1995 (known as *PFEER*) ([SI 1995/743](#)) and HSE approved code of practice and guidance *Prevention of fire and explosion, and emergency response on offshore installations* ([HSE L65](#))

Offshore Installations (Safety Case) Regulations 2005 (known as *SCR*) ([SI 2005/3117](#)) and HSE guidance ([HSE L30](#))

Personal Protective Equipment Regulations 2002 (known as the *PPE Regulations*) ([SI 2002/1144](#))

Personal Protective Equipment at Work Regulations 1992 (known as the *PPE at Work Regulations*) ([SI 1992/2966](#)), amended by the Health and Safety (Miscellaneous Amendments) Regulations 2002 ([SI 2002/2174](#)), and HSE guidance ([HSE L25](#)). Also see **4.2.4**.

Provision and Use of Work Equipment Regulations 1998 (known as *PUWER*) ([SI 1998/2306](#)), amended by the Health and Safety (Miscellaneous Amendments) Regulations 2002 ([SI 2002/2174](#)), and HSE approved code of practice *Safe use of work equipment* ([HSE L22](#)). Also see **4.2.3**.

Reporting of Injuries, Diseases and Dangerous Occurrences Regulations 2013 (known as *RIDDOR 2013*), plus HSE guidance *A guide to the Reporting of Injuries, Diseases and Dangerous Occurrences Regulations 2013* ([HSE INDG453](#) (Rev1) and, for offshore, [HSE Operations Notice 30](#)). Also see **4.2.11**.

Work at Height Regulations 2005 (known as the *WAHR*) ([SI 2005/735](#)) as amended by the Work at Height (Amendment) Regulations 2007 ([SI 2007/114](#)), and HSE guidance ([HSE INDG401](#)). Also see **4.2.7**.

Workplace (Health, Safety and Welfare) Regulations 1992 ([SI 1992/3004](#)) as amended by the Quarries Regulations 1999 ([SI 1999/2024](#)) and the Health and Safety (Miscellaneous Amendments) Regulations 2002 ([SI 2002/2174](#)), plus the HSE approved code of practice and guidance *Workplace health, safety and welfare* ([HSE L24](#)).

## **4.2 Brief explanation of some UK legislation**

### **4.2.1 General**

**4.2.1.1** In general terms, the work described in this IRATA International code of practice is covered by the Health and Safety at Work etc. Act 1974 and the Mineral Workings (Offshore Installations) Act 1971. This legislation places general duties on employers, clients, contractors, owners, employees and the self-employed. Under the umbrella of these acts, many regulations have been made, which expand on these general duties. Some of these regulations deal with particular issues, e.g. first aid, while other regulations made under the acts bring into force the requirements of European (EC) directives. These regulations draw attention to the duties of clients, owners and designers of structures to ensure that, so far as is reasonably practicable, any work to be carried out in the workplace is able to be done so safely. Every employer is required to ensure that they comply with all legal safety requirements relating to the type of work being undertaken and at the particular worksite concerned.

**4.2.1.2** Regulations are often tied in with other regulations. For example, where work is classed as construction work under the Construction (Design and Management) Regulations 2007 (CDM Regulations) other regulations also apply, such as the Provision and Use of Work Equipment Regulations 1998 (PUWER) and the Lifting Operations and Lifting Equipment Regulations 1998 (LOLER). Even where these regulations do not apply, it is possible that their requirements could be regarded as 'being a reasonably practicable safe system of work' under the Health and Safety at Work etc. Act 1974. Employers and persons or companies commissioning rope access work are advised, therefore, to consider the requirements of these regulations.

**4.2.1.3** Some sections of the Health and Safety at Work etc. Act 1974 apply beyond the mainland of Great Britain to specified offshore areas and work activities. The Health and Safety at Work etc. Act 1974 (Application outside Great Britain) Order 2013, which came into effect on 6 April 2013, provides detail. Guidance is given in Offshore Information Sheet 1/2013.

### **4.2.2 Construction (Design and Management) Regulations**

**4.2.2.1** The CDM Regulations place a legal responsibility on the client to ensure that those they employ have an adequate level of competence for the work being undertaken and that they are able to meet the requirements to work safely.

**4.2.2.2** Where the CDM Regulations apply, a health and safety file is required. This has to contain information in connection with the safety aspects of the construction work. Some or the entire file should be made available to those planning to carry out rope access work. When the construction work has been completed, it may be necessary to update the health and safety file. Similar requirements apply offshore, under the Offshore Installations (Safety Case) Regulations 2005 (SCR).

### **4.2.3 The Provision and Use of Work Equipment Regulations**

**4.2.3.1** The Provision and Use of Work Equipment Regulations 1998 (PUWER) require risks to people's health and safety from equipment that they use at work to be prevented or controlled. The regulations apply to all work equipment, including lifting equipment. Under PUWER, it is required that suitable work equipment is selected in terms of its construction and design, where it is to be used and the purpose for which it is to be used.

**4.2.3.2** In general terms, PUWER require that equipment provided for use at work is:

- a) suitable for the intended use;
- b) safe for use, maintained in a safe condition and, in certain circumstances, inspected to ensure this remains the case;
- c) used only by people who have received adequate information, instruction and training;
- d) accompanied by suitable safety measures, e.g. protective devices, markings, warnings.

### **4.2.4 Personal Protective Equipment at Work Regulations**

**4.2.4.1** The Personal Protective Equipment at Work Regulations 1992 (the PPE at Work Regulations), as amended, cover equipment for work at height. The main requirement of the regulations is that suitable personal protective equipment (including some clothing) is supplied and used at work wherever there are risks to health and safety that cannot be adequately controlled in other ways. There is a useful guidance document on these regulations, which includes the regulations: HSE guidance document Personal Protective Equipment at Work Regulations 1992, Guidance on Regulations (HSE L25).

**4.2.4.2** The PPE at Work Regulations also require that personal protective equipment (PPE):

- a) is properly assessed before use to ensure it is suitable;
- b) is maintained and stored properly;
- c) is provided with instructions on how to use it safely;
- d) is used correctly by employees.

*NOTE Under the Personal Protective Equipment at Work Regulations 1992, there is a requirement for operatives to wear appropriate protective helmets, even though the Construction (Head Protection) Regulations 1989 were revoked on 06 April 2013.*

### **4.2.5 Lifting Operations and Lifting Equipment Regulations**

**4.2.5.1** The Lifting Operations and Lifting Equipment Regulations 1998 (LOLER) is aimed at ensuring that all lifting operations are properly planned and managed; that lifting equipment is used in a safe manner and that it is thoroughly examined (has a detailed inspection) at suitable intervals by a competent person.

**4.2.5.2** Lifting equipment under LOLER means work equipment that lifts or lowers loads and includes its attachments used for anchoring, fixing or supporting it, for example, strops, chains, slings, eye-bolts, anchorage equipment such as rigging and associated items used in rope access methods, including ropes; karabiners, harnesses and lanyards and counterbalanced roof rigs.

**4.2.5.3** It is important to note that under LOLER, the term load includes a person.

**4.2.5.4** LOLER applies to a wide range of lifting equipment and lifting operations and includes, for example, personal suspension equipment used during rope access work.

**4.2.5.5** LOLER requires lifting equipment to be thoroughly examined (given a detailed inspection) by a competent person before first use and at intervals not exceeding six months, or in accordance with a written examination scheme. In addition to these examinations, LOLER require additional thorough examinations to be carried out where circumstances liable to jeopardize safety have occurred. Thorough examinations are required to be recorded in a written report. Unless this has been done, it is not legal for the lifting equipment to be used.

#### **4.2.6 Management of Health and Safety at Work Regulations**

The Management of Health and Safety at Work Regulations 1999 require employers to take into account employees' capabilities with regard to health and safety when allocating them work. The regulations require that, before rope access techniques are selected for a particular job, employers carry out a risk assessment and set out clear requirements for all aspects of the work. (Risk assessment is addressed in Part 2 and in Part 3, Annex A. A useful HSE guidance document is *Five steps to risk assessment* [[INDG 163](#)]). In addition, the work project should be assessed carefully to ensure that the method of access is appropriate for the type and quality of the work to be carried out.

#### **4.2.7 Work at Height Regulations**

**4.2.7.1** As a result of the European Council (EC) Directive 2001/45/EC concerning minimum safety and health requirements for the use of equipment for work at height (known as the Temporary Work at Height Directive or TWAHD), a major change was made to UK legislation by the introduction of the Work at Height Regulations 2005. These regulations consolidated previous UK legislation on working at height and added further requirements. The regulations were amended in 2007 to take account of professionals working in the climbing, mountaineering and caving arenas.

**4.2.7.2** The Work at Height Regulations 2005 (WAHR), including its 2007 amendment, apply to all work at height where there is a risk of a fall liable to cause personal injury. This applies above, at or below ground level. The regulations place duties on employers, the self-employed, and any person that controls the work of others to the extent of their control (e.g. facilities managers or building owners who may contract others to work at height).

**4.2.7.3** Under WAHR, work at height has to be properly planned, appropriately supervised and carried out in a safe manner. This includes the need to plan for emergencies and rescue. In addition, employers are required to ensure that work at height is only carried out when the weather conditions do not jeopardize the health and safety of persons involved in the work (see Regulation 4).

**4.2.7.4** Regulation 5 of WAHR requires every employer to ensure that no person engages in any activity, including organization, planning and supervision, in relation to work at height or work equipment for use in such work unless he/she is competent to do so or, if being trained, is being supervised by a competent person.

**4.2.7.5** Regulation 6 of WAHR requires every employer to take account of a risk assessment under the MHSW Regulations (Regulation 3). WAHR gives a hierarchy of protection measures, where the preferred option is to eliminate the risk, e.g. by not working at height at all, with other, less preferred, options lower down the list.

**4.2.7.6** Regulation 7 of WAHR requires collective protection measures to be given priority over personal protection measures. Equipment has to be appropriate to the nature of the work to be performed and foreseeable loadings. When selecting work equipment for use in work at height, the following have to be taken into account:

- a) the working conditions and the risks to the safety of persons at the place where the work equipment is to be used;
- b) in the case of work equipment for access and egress, the distance to be negotiated;
- c) the distance and consequences of a potential fall;
- d) the duration and frequency of use;



- e) the need for easy and timely evacuation and rescue in an emergency;
- f) any additional risk posed by the use, installation or removal of that work equipment or by evacuation and rescue from it.

**4.2.7.7** Regulation 9 of WAHR requires every employer to ensure that no person at work passes across or near (or works on, from or near) a fragile surface where it is reasonably practicable to carry out work safely, and under appropriate ergonomic conditions, without their doing so.

**4.2.7.8** Regulation 12 of WAHR requires that work equipment exposed to conditions causing deterioration which is liable to result in dangerous situations is inspected at suitable intervals and each time that exceptional circumstances which are liable to jeopardise the safety of the work equipment have occurred. Inspection, care and maintenance of equipment are covered in Part 2 of this IRATA International code of practice.

## **4.2.8 Manual Handling Operations Regulations**

**4.2.8.1** The Manual Handling Operations Regulations 1992 (as amended March 2004) (MHOR) requires a risk assessment to be carried out on manual handling tasks. The HSE guidance on the Manual Handling Operations Regulations, (HSE L23) includes a risk assessment filter and checklist to help employers assess manual handling tasks. HSE document [Manual handling – frequently asked questions](#), provides answers to common questions.

**4.2.8.2** The employer's duty is to avoid manual handling as far as reasonably practicable if there is a possibility of injury. If this cannot be done, the employer has to reduce the risk of injury as far as reasonably practicable. If an employee complains of discomfort, any changes to work made to avoid or reduce manual handling has to be monitored to check they are having a positive effect. If the changes are not working satisfactorily, alternatives have to be considered.

**4.2.8.3** The regulations set out a hierarchy of measures to reduce the risks of manual handling. These are in regulation 4(1) and are as follows:

- a) avoid hazardous manual handling operations so far as reasonably practicable;
- b) assess any hazardous manual handling operations that cannot be avoided;
- c) reduce the risk of injury so far as reasonably practicable.

**4.2.8.4** In addition, employees have duties to take reasonable care of their own health and safety and that of others who may be affected by their actions. They must communicate with their employers so that they too are able to meet their health and safety duties.

## **4.2.9 Additional regulations when working offshore**

For those working or intending to work offshore, a few additional regulations apply. Legislation that applies to offshore working includes the Offshore Installations and Wells (Design and Construction) Regulations 1996 (DCR), the Offshore Installations and Pipeline Works (Management and Administration) Regulations 1995 (MAR) and the Offshore Installations (Prevention of Fire and Explosion and Emergency Response) Regulations, 1995 (PFEER).

## **4.2.10 Regulations dealing with specific types of hazard**

There are some regulations which deal with specific types of hazard. Two examples are the Control of Substances Hazardous to Health Regulations 2002 (COSHH) and its 2003 amendment, and the Control of Asbestos at Work Regulations 2006. There are HSE approved codes of practice for both these regulations. The Noise at Work Regulations 1989 require employers to assess the noise levels and to take appropriate action, e.g. provide operatives with hearing protectors. Employers need to understand fully the requirements of such regulations when they plan to undertake work that might involve their workforce coming into contact with hazardous materials or conditions. This applies to both on and offshore working.

#### **4.2.11 Reporting of Injuries, Diseases and Dangerous Occurrences Regulations**

**4.2.11.1** The reporting of accidents and ill health at work is a legal requirement under the Reporting of Injuries, Diseases and Dangerous Occurrences Regulations, 2013 (RIDDOR 2013). The regulations require that in the event of a fatal accident, major injury or dangerous occurrence, the responsible person notifies the Health and Safety Executive (HSE) by the quickest practical means and these incidents should be reported to the Incident Control Centre (ICC).

**4.2.11.2** Since 6 April 2012, the over-three-day reporting requirement for people injured at work changed to more than seven days. From that date, it became only necessary to report injuries that lead to an employee or self-employed person being away from work, or unable to perform their normal work duties, for more than seven consecutive days as the result of an occupational accident or injury (not counting the day of the accident but including weekends and rest days). The report must be made within 15 days of the accident. Such reports should be made to the ICC online.

**4.2.11.3** The regulations were further amended on 01 October 2013. The main changes made were:

- a) The classification of 'major injuries' to workers has been replaced with a shorter list of 'specified injuries'.
- b) The existing schedule detailing 47 types of industrial disease has been replaced with eight categories of reportable work-related illness.
- c) Fewer types of 'dangerous occurrence' require reporting.

**4.2.11.4** The changes affect all employers, including the self-employed. Information and guidance is available on the HSE website at: <http://www.hse.gov.uk/riddor/>.

**4.2.11.5** The amendments do not alter the duties and responsibilities already placed on employers. For example, businesses still have a legal duty to make arrangements to ensure their employees receive immediate attention if they are injured or taken ill at work. Neither do the amendments affect how an incident at work is reported and the criteria that determine whether an incident should be investigated.

**4.2.11.6** Under EU law, employers and others with responsibilities under RIDDOR still have to keep a record of all over-three-day injuries. The record required under the Social Security (Claims and Payments) Regulations 1979, is enough to satisfy this requirement.

**4.2.11.7** These regulations require any accident where the time lost by the injured person is over three days, or where a serious incident (dangerous occurrence) has occurred, to be recorded. In addition, information on the time lost by the injured person and others in the work team has to be provided.

#### **4.2.12 Helpful documents**

**4.2.12.1** Two HSE documents that provide valuable information for rope access technicians and their employers are *Health and Safety in Construction (HSG 150)* and *Health and Safety in Roof Work (HSG 33)*. The documents cover topics such as organizing the site, the essentials of health and safety, health and safety management and the law. Although following the guidance in the documents is not a legal requirement, the documents do provide sufficient information to enable the user to comply with the law.

**4.2.12.2** HSE's *Leading health and safety at work (INDG 417)* provides leadership actions for directors and board members.

**4.2.12.3** Sufficient, effective supervision and adequate support from managers play a vital part in ensuring a safe system of work. The use of the phrase *human factors* by supervisors and managers is wide-ranging. Advice is given in HSE's document [Introduction to human factors](#). More good advice is



given in: *Reducing error and influencing behaviour*, ([HSG 48](#)). HSE document [Leadership and worker involvement toolkit](#) addresses reducing harm by learning from the best in the construction industry.

**4.2.12.4** A good occupational safety and health management system is important and [BS OHSAS 18001: 2007](#) provides a good model. Also, see HSE document *Successful safety management* ([HSG65](#)).

### **4.3. Standards and legal requirements**

**4.3.1** The use of standards is voluntary, in that it is not a statutory requirement to comply with codes of practice or to conform to product standards. However, standards are often used to support the law. In the case of HSE approved codes of practice, following them enables users to ensure they comply with the law.

**4.3.2** The Personal Protective Equipment Regulations 2002, which are based on the Personal Protective Equipment Directive (89/686/EEC) (known as the PPE directive), require that equipment classified under the directive as PPE conforms to the directive, which includes the need to carry CE marking.

**4.3.3** European Standards (ENs) are used to help prove conformance of a product to the PPE directive. To use a European Standard straightforwardly as a route to conformance to the directive, the standard has to be what is known as harmonised. This means it has been formally confirmed that the standard meets the requirements of the basic health and safety requirements of Annex II of the directive, and that it has been referenced in the Official Journal of the European Union (OJEU). If a product conforms to a harmonized European Standard, there is a presumption of conformity with the PPE directive, in terms of meeting the basic health and safety requirements of Annex II. Assuming other requirements of the directive have been satisfied, this then allows the equipment to be marked with the symbol CE and other marking.

**4.3.4** There are three categories of PPE, ranging from simple items like gardening gloves (category I) to category III equipment for protection against mortal danger, e.g. harnesses. Most rope access equipment is classed as PPE category III. In this case, the equipment also has to carry the number of the notified body, i.e. the body responsible for checking that the product conforms to the directive, after type testing to the standard by an independent test house.

**4.3.5** Conformance of products to a European Standard is not the only way in which products can claim conformance to the PPE directive and be able to carry CE marking. For example, where appropriate European Standards do not exist, another standard, such as an ISO Standard, could be used or manufacturers can use their own standard, which is described as the technical file route.

**4.3.6** The primary function of CE marking is to protect against barriers to trade within the European Union. It is not meant to be taken as a mark of quality.